

I-7532RM-FD User Manual

Version 1.0.0, Oct. 2023

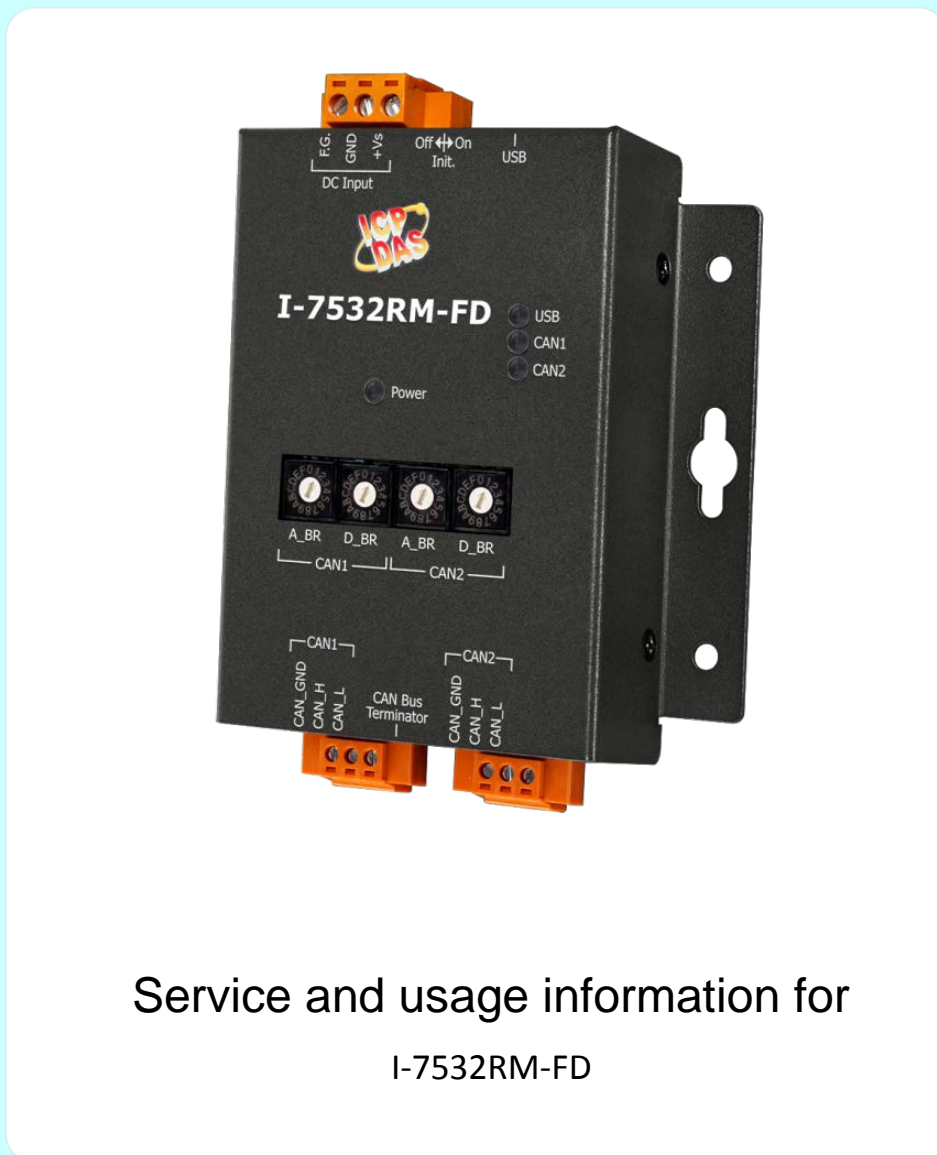

Service and usage information for
I-7532RM-FD

Warranty

All products manufactured by ICP DAS are under warranty regarding defective materials for a period of one year, beginning from the date of delivery to the original purchaser.

Warning

ICP DAS assumes no liability for any damage resulting from the use of this product. ICP DAS reserves the right to change this manual at any time without notice. The information furnished by ICP DAS is believed to be accurate and reliable. However, no responsibility is assumed by ICP DAS for its use, not for any infringements of patents or other rights of third parties resulting from its use.

Copyright

Copyright © 2023 by ICP DAS Co., Ltd. All rights are reserved.

Trademark

The names used for identification only may be registered trademarks of their respective companies.

Contact us

If you have any problem, please feel free to contact us.
You can count on us for quick response.

Email: service@icpdas.com

Table of Contents

1. Introduction	5
1.1. Specifications	6
1.2. Features	7
2. Technical data	8
2.1. Appearance	8
2.2. Pin Assignment	9
2.3. LED Indicator	10
2.4. Rotary Switch	11
2.5. Terminal Resistor Setup	12
2.6. Wire Connection	14
2.7. CAN Bus Driving Capability	15
3. Software Utility	16
3.1. Install the I-7532-FD Utility	16
3.2. Setting up the I-7532RM-FD	19
3.3. Start to use I-7532-FD Utility tool	20
3.3.1. Get Device Configuration	22
3.3.2. CAN Bus Configuration	23
3.3.2.1. Forwarding Rule Examples	26
3.3.3. CAN Filter Configuration	28
3.3.4. CAN Mapping Rule Configuration	30
3.3.4.1. Mapping Rule Examples	33
3.3.5. CAN Merging Rule Configuration	35
3.3.5.1. Merging Rule Examples	37
3.3.6. CAN Splitting Rule Configuration	39
3.3.6.1. Splitting Rule Examples	41
3.3.7. CAN Status Information	43
4. Firmware Upgrade	44
5. Appendix	48
5.1. Revision History	48

5.2.	Dimension	49
5.3.	Valid Data Phase Bit Rate.....	50

1. Introduction

I-7532RM-FD is a local CAN/CAN FD (CAN with Flexible Data-Rate) bridge used to establish a connection between two CAN/CAN FD networks. It can increase the bus loading capacity, extend communication distance, connect CAN/CAN FD networks with different baud rate and support messages transform between CAN and CAN FD networks.

I-7532RM-FD supports messages transform from CAN to CAN, CAN to CAN FD, CAN FD to CAN and CAN FD to CAN FD. Besides, It also supports frame mapping rule, merging rule (combine multiple CAN messages to one CAN FD message) and splitting rule (split one CAN FD message to multiple CAN messages) for some specific messages transformation. Users can freedom to use these rules for their application. After connecting USB port with PC, user can use I-7532-FD Utility tool to configure module's baud rate and rules. Then user can simple and easy to use the module.

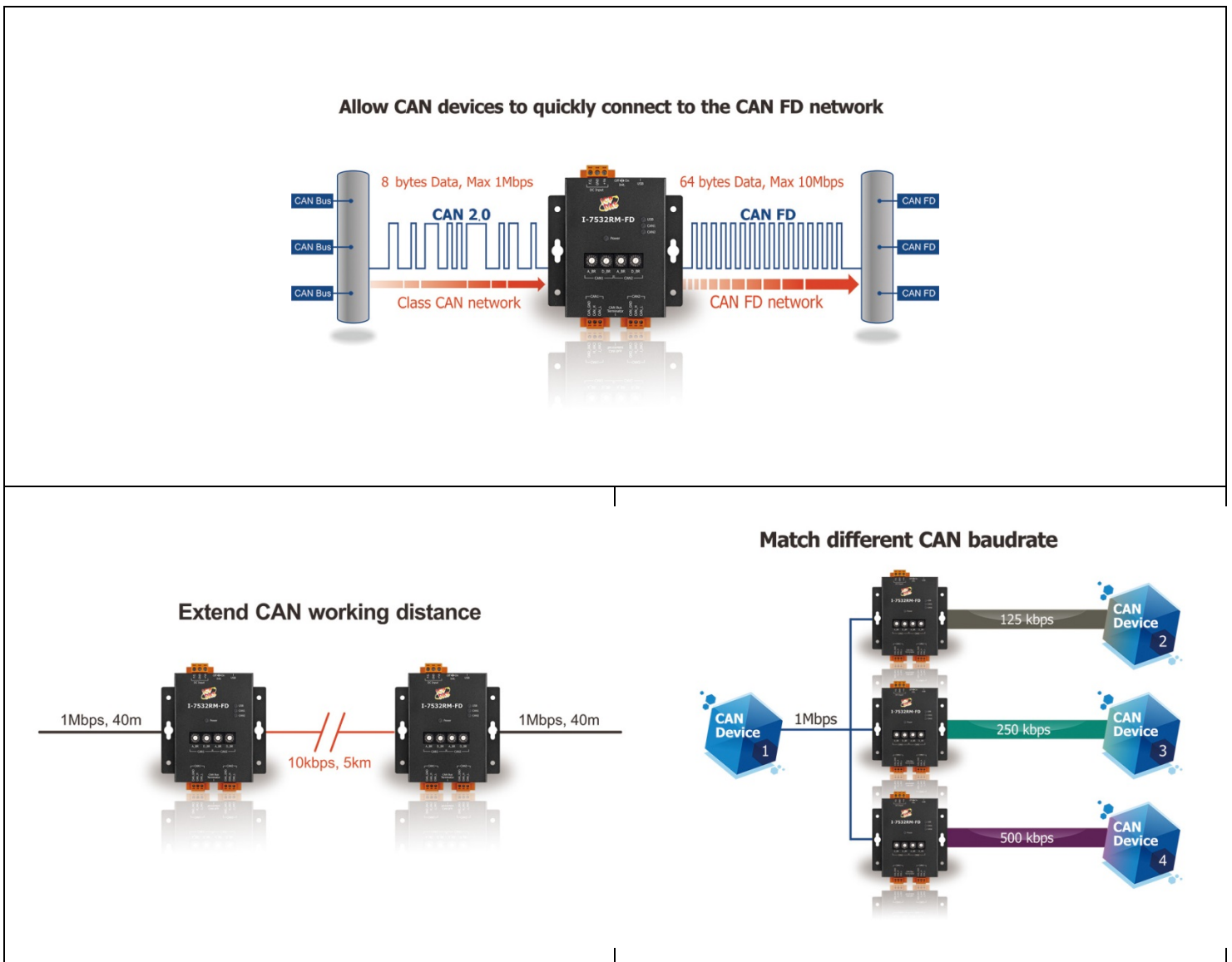

1.1. Specifications

CAN Interface	
Channel Number	2
Connector	3-pin terminal-block connector x 2
Transmission Speed	CAN bit rates: 10 ~ 1000 kbps, CAN FD bit rates for data field: 100 ~ 10000 kbps
Terminal Resistor	DIP switch for the 120 Ω terminal resistor
Isolation	3000 VDC for DC-to-DC, 2500 Vrms for photo-coupler
Specification	ISO 11898-2, CAN 2.0 A/B and FD
Max Data Flow	10,000 FPS for Tx/Rx (each port)
Receive Buffer	128 data frames
USB Interface	
Connector	1 x USB (Type C)
Compatibility	USB 2.0 High Speed (480Mbps)
Software Driver	Built-in Windows 7/8.1/10/11
LED	
Round LED	Power, USB, CAN1, CAN2 LEDs
Power	
Power supply	Unregulated +10 ~ +30 V _{DC}
Protection	Power reverse polarity protection, Over-voltage brown-out protection
Power Consumption	0.05A @ 24V _{DC}
Mechanism	
Installation	Wall Mount or DIN-Rail
Dimensions	102 mm x 120 mm x 37.5 mm (W x L x H)
Environment	
Operating Temp.	-25 ~ 75 °C
Storage Temp.	-30 ~ 80 °C
Humidity	10 ~ 90% RH, non-condensing

1.2. Features

- Compatible with the ISO 11898-2 standard.
- Compatible with CAN specification 2.0 A/B and FD.
- CAN FD support for ISO and Non-ISO (Bosch) standards switchable.
- CAN FD bit rates for data field from 100 kbps to 10000 kbps
- CAN bit rates from 10 kbps to 1000 kbps.
- Supports CAN bus message filtering configuration..
- Support CAN/CAN FD frame forwarding rules, including basic forwarding rule, mapping rule, merging rule and splitting rule. When receiving a frame on one CAN port, this frame is processed via these rules and then send out to another port. The process priority level of these rules are “merging rule” = “splitting rule” > “mapping rule” > “basic forwarding rule”.
- Support checking the status of the CAN network via Utility tool.
- Messaging traffic of each port up to 10,000 fps.
- The baud rate of each port can be different for highly flexibility.
- Built-in switchable 120 ohm terminal resistor for CAN network
- Rotary switch for CAN/CAN FD baud rate or user-defined CAN/CAN FD baud rate via Utility tool.

2. Technical data

2.1. Appearance

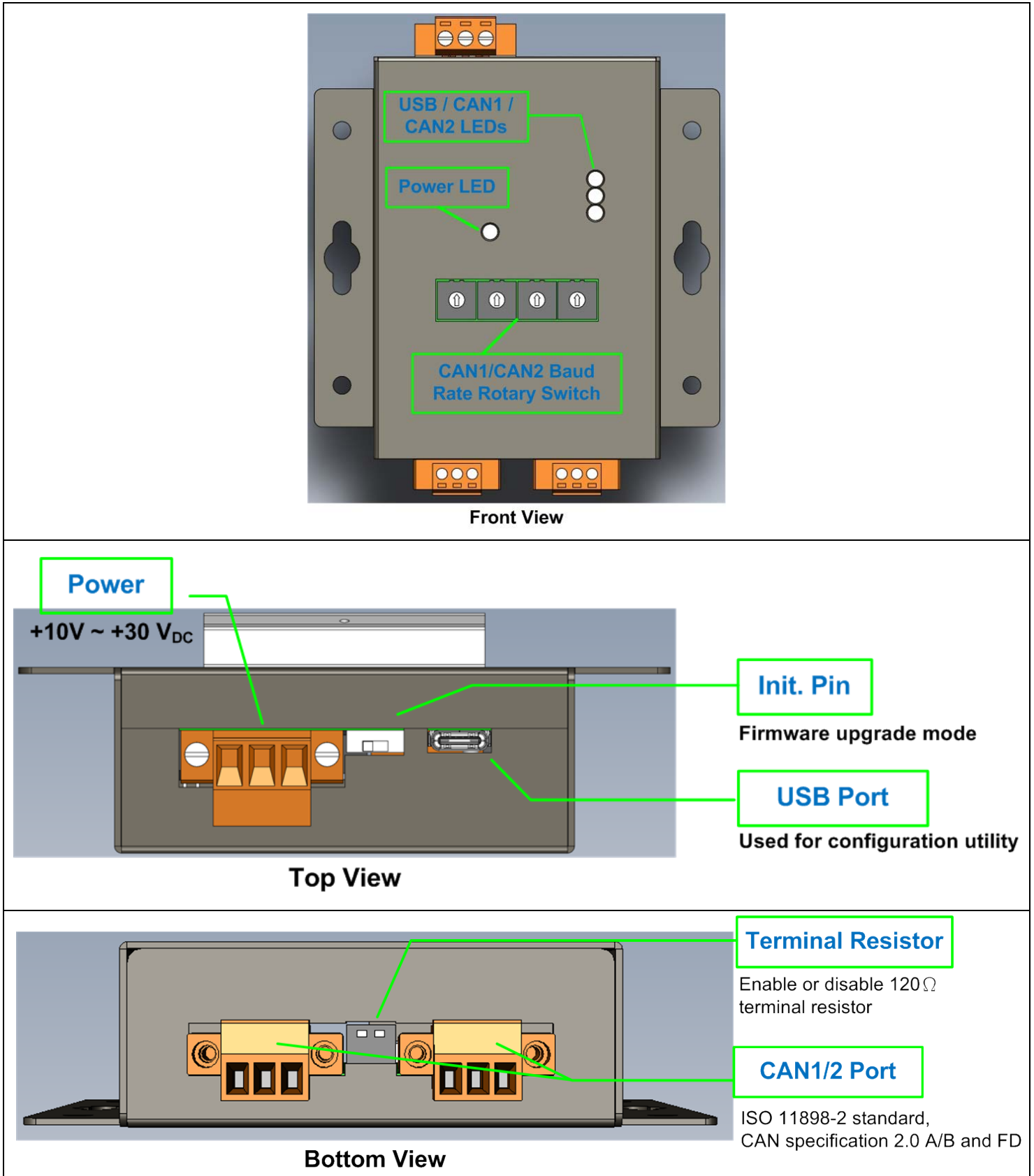
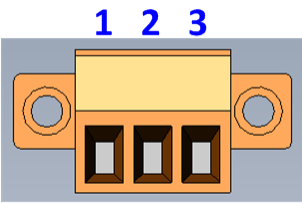
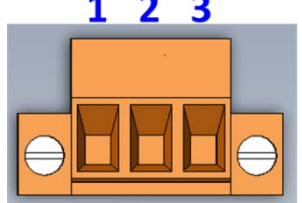

Figure 2-1-1 Appearance of I-7532RM-FD

2.2. Pin Assignment

The pin assignments of CAN port and power connector of I-7532RM-FD is shown in the following tables.

Table 2-2-1 Pin Assignment

Port	Schematic diagram	Pin	Description
CAN		1. CAN_GND	CAN ground of CAN port
		2. CAN_H	CAN_High bus line of CAN port.
		3. CAN_L	CAN_Low bus line of CAN port.
Power		1. +Vs	Voltage Source Input. +10VDC ~ +30VDC.
		2. GND	Power Ground.
		3. F.G.	Frame Ground.

Sometimes, the CAN_GND voltage level of different CAN devices on a CAN bus system are not equal. In this case, it could cause some problems and derogate the system stability. There is one way to relieve this situation; users can connect the CAN_GND of different CAN devices with each other to balance the voltage level of CAN_GND.

Electronic circuits are always influenced by different levels of Electro-Static Discharge (ESD), which become worse in a continental climate area. F.G. provides a path for conducting the ESD to the earth ground. Therefore, connecting the F.G. correctly can enhance the capability of the ESD protection and improve the module's reliability.

Wiring of CAN_GND and F.G. is not necessary; users can modify the configuration of wiring according to real applications.

2.3. LED Indicator

There are 4 LEDs on the I-7532RM-FD. One for power indication, one for USB indication and two for CAN bus indication. The LED assignment and description are shown as follows.

Table 2-3-1 LED Description

LED Name	Status	Description
Power	Red On	When power on the I-7532RM-FD, this LED is turned on.
USB	Green On	USB cable connected
	Green Flash	Communicating with Utility via USB
CAN1	Red On	CAN1 Bus Off
	Red Flash	CAN1 Error warning or error passive
	Green On	CAN1 Idle.
	Green Flash	Transmitting or receiving CAN messages on CAN1 port
CAN2	Red On	CAN2 Bus Off
	Red Flash	CAN2 Error warning or error passive
	Green On	CAN2 Idle.
	Green Flash	Transmitting or receiving CAN messages on CAN2 port

NOTE:

In “Firmware Upgrade Mode”, the USB, CAN1 and CAN2 will polling to flash red/green led per 200 ms.

2.4. Rotary Switch

There are 4 rotary switches on the I-7532RM-FD for configuring CAN1/2 arbitration and data phase baud rate. The descriptions are as follows.

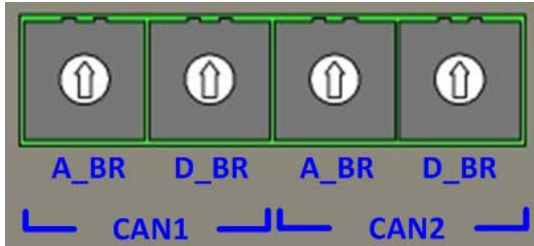

CAN1 A_BR/D_BR → CAN1 Arbitration/Data phase baud rate

CAN2 A_BR/D_BR → CAN2 Arbitration/Data phase baud rate

A_BR (Arbitration phase baud rate) is defined as follows:

Switch	0	1	2	3	4	5	6	7
Baud (bps)	User-defined	10k	20k	40k	50k	80k	100k	
Switch	8	9	A	B	C	D	E	F
Baud (bps)	125k	200k	250k	400k	500k	600k	800k	1M

D_BR (Data phase baud rate) is defined as follows:

Switch	0	1	2	3	4	5	6	7
Baud (bps)	CAN Mode	User-defined	100k	200k	250k	400k	500k	800k
Switch	8	9	A	B	C	D	E	F
Baud (bps)	1M	2M	2.5M	3M	4M	5M	6M	10M

NOTE:

1. When the D_BR switch is "0" (CAN mode), this CAN port will be set to CAN mode, using only the setting of the A_BR switch as the CAN baud rate and not supporting any CAN FD messages,
2. When A_BR and D_BR switches are set to "1", the baud rate of this CAN port will be user-defined and set by the utility.

2.5. Terminal Resistor Setup

In order to minimize the reflection effects on the CAN bus line, the CAN bus line has to be terminated at both ends by two terminal resistors as in the following figure. According to the ISO 11898-2 spec, each terminal resistor is 120Ω (or between 108Ω~132Ω). The bus topology and the positions of these terminal resistors are shown as following figure.

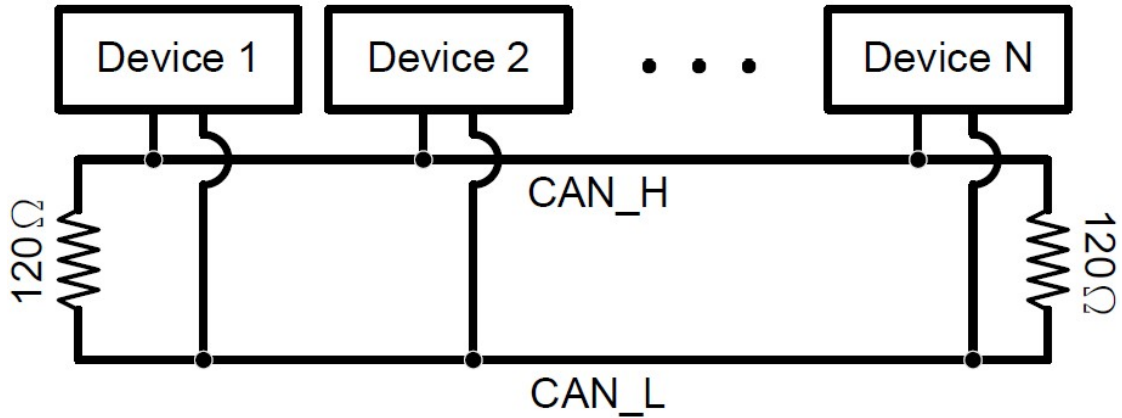

Figure 2-5-1 CAN bus network topology

Each I-7532RM-FD includes two build-in 120Ω terminal resistor, users can decide to enable it or not. The DIP switch for terminal resistor is on the upper of the CAN connector.

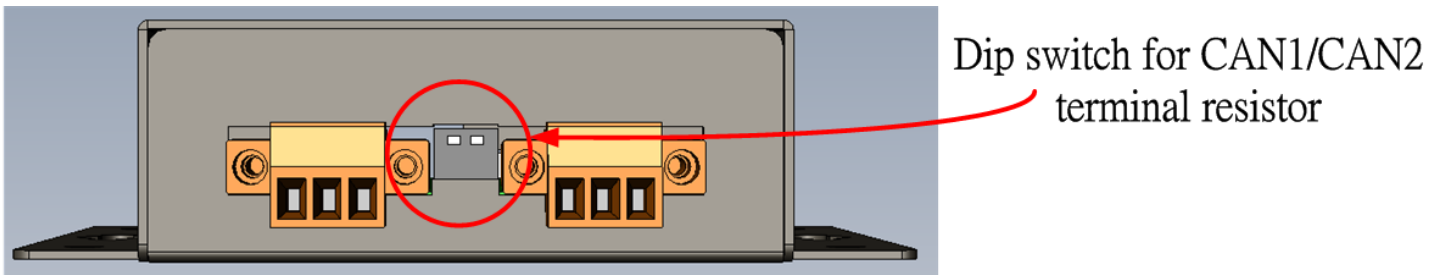

Figure 2-5-2 Location of Terminal resistor DIP Switch

The following DIP switch statuses present the condition if the terminal resistor is active (default) or inactive.

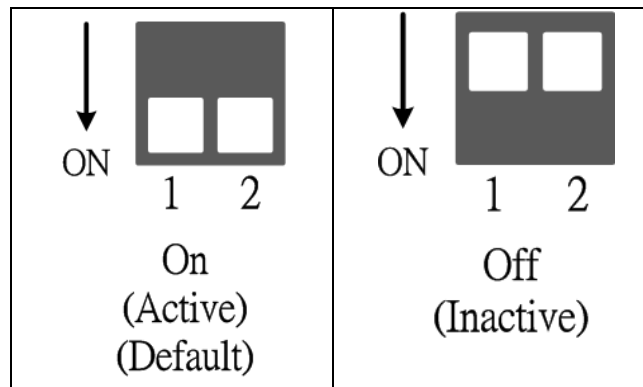

Figure 2-5-3 Adjustment of Terminal Resistance

Generally, if your application is as follows, we recommend you to enable the terminal resistor.

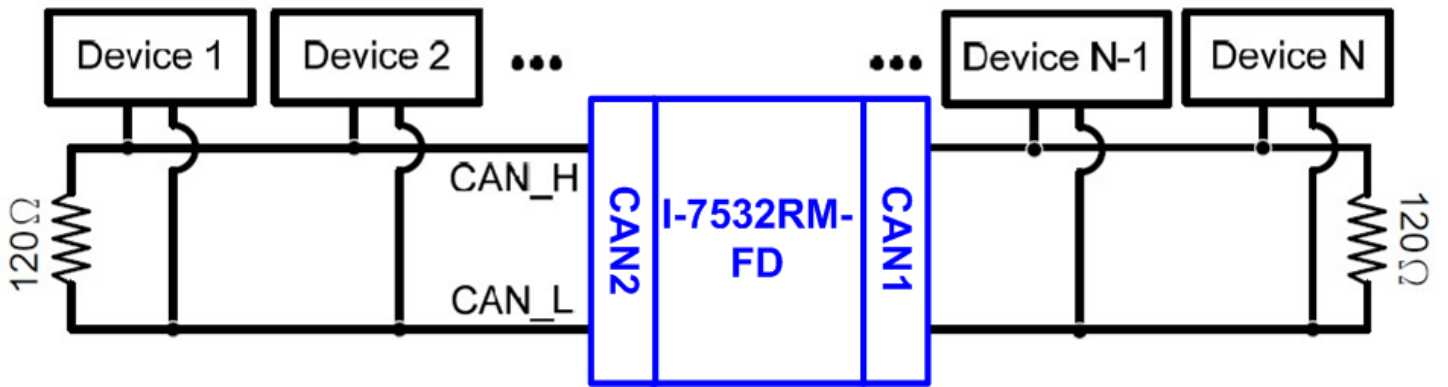

Figure 2-5-4 Application 1

If your application is like the structure as follows, the terminal resistor is not needed.

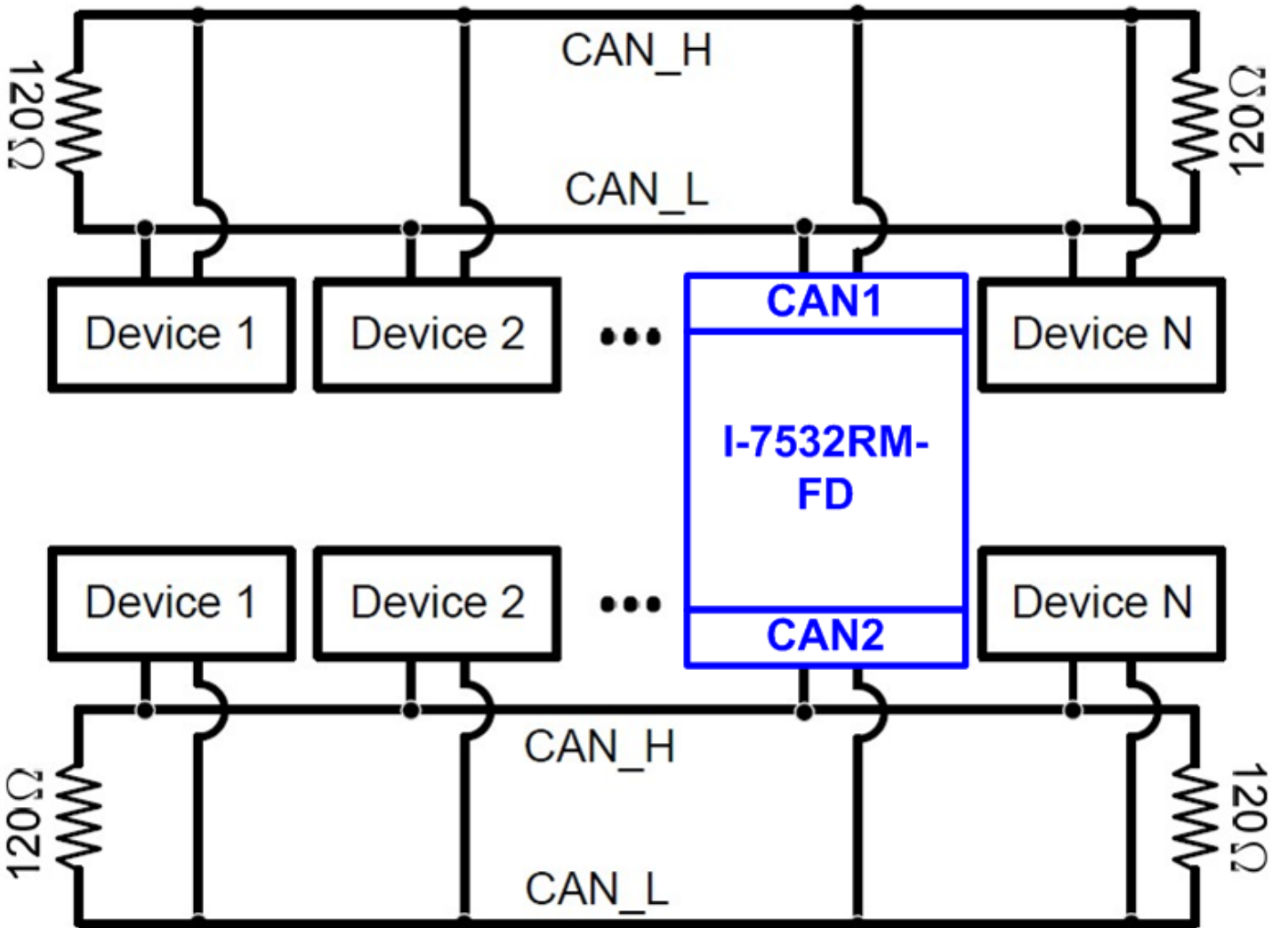

Figure 2-5-5 Application 2

2.6. Wire Connection

The wire connection of the I-7532RM-FD is displayed below.

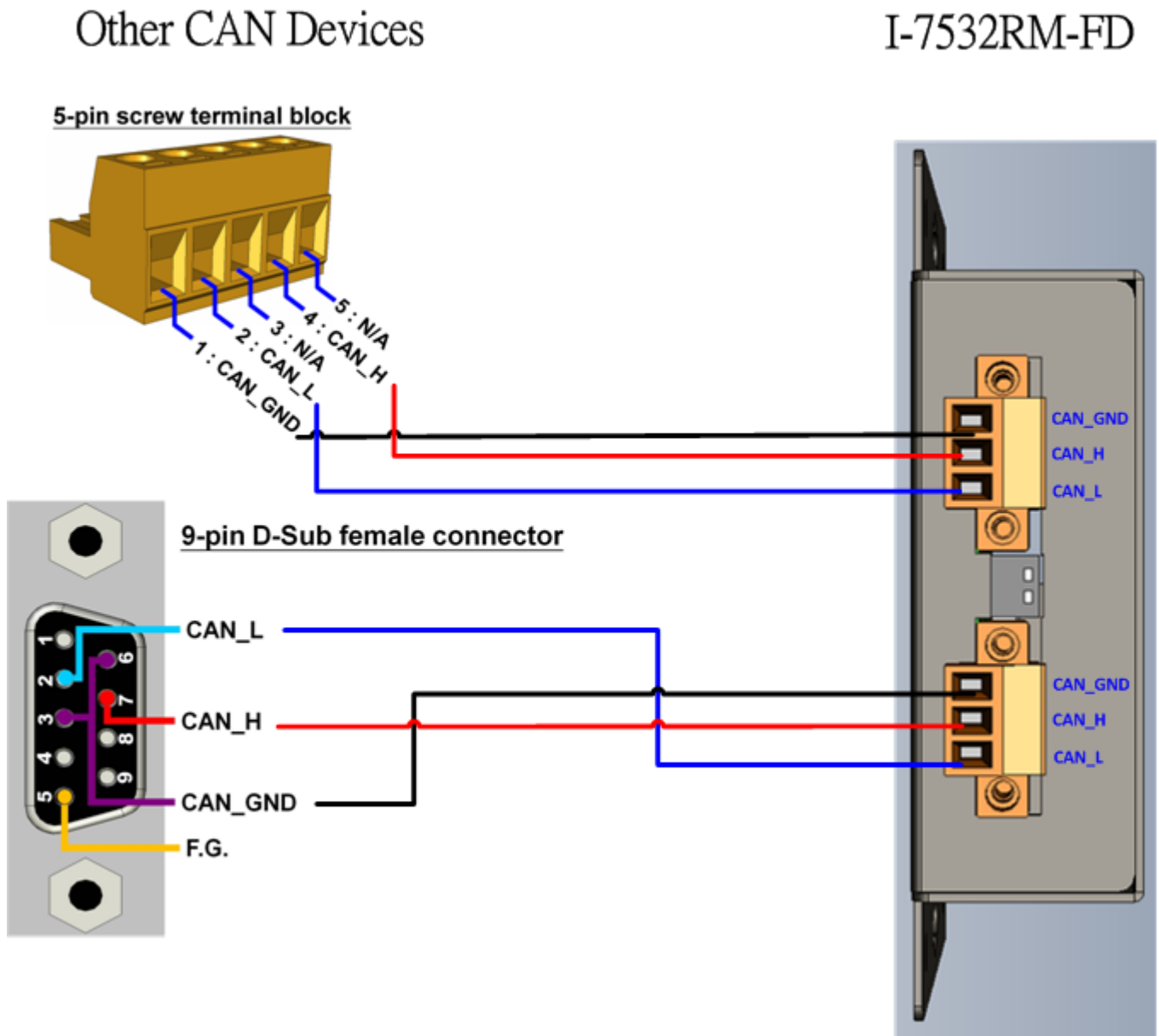

Figure 2-6-1 Wire Connection for I-7532RM-FD

2.7. CAN Bus Driving Capability

Before introducing the driving capability of the I-7532RM-FD, some characteristics of copper cable must be assumed. The recommended AC parameters are 120Ω impedance and 5ns/m line delay, and the DC parameters are shown in the table below.

Table 2-7-1 Recommended DC parameter for CAN Bus Line

Wire Cross-Section [mm ²]	Resistance [Ω/km]
~0.25 (AWG23)	< 90
~0.5 (AWG20)	< 50
~0.8 (AWG18)	< 33
~1.3 (AWG16)	< 20

Under the condition described above, users can refer to the following table to know the maximum node number in each segment following ISO 11898-2 and the maximum segment length when using different type of wire.

Table 2-7-2 Driving Capability

Wire Cross-Section [mm ²]	The maximum segment length [m] under the case of specific node number in this segment			
	16 Nodes	32 Nodes	64 Nodes	100 Nodes
~0.25 (AWG23)	< 220	< 200	< 170	< 150
~0.5 (AWG20)	< 390	< 360	< 310	< 270
~0.8 (AWG18)	< 590	< 550	< 470	< 410
~1.3 (AWG16)	< 980	< 900	< 780	< 670

3. Software Utility

When users want to use user-defined CAN/CAN FD baud rate, CAN/CAN FD message filter and CAN mapping, merging, splitting rule function on the I-7532RM-FD, the I-7532-FD Utility tool may be needed.

NOTE: I-7532M-FD & I-7532RM-FD use the same “I-7532-FD Utility” tool.

3.1. Install the I-7532-FD Utility

Step 1: Get the I-7532-FD Utility

The software is located at:

[I-7532-FD Utility](#)

Step 2: Install .NET Framework 3.5 component

The I-7532-FD Utility tool requires the .NET Framework 3.5 components. After executing the “Setup.msi” file, it will start to install .NET Framework 3.5 components.

Step 3: Install Utility tool

After installing the .Net Framework components, the software will continue to install the Utility tool.

1. Click the “Next” button to continue.

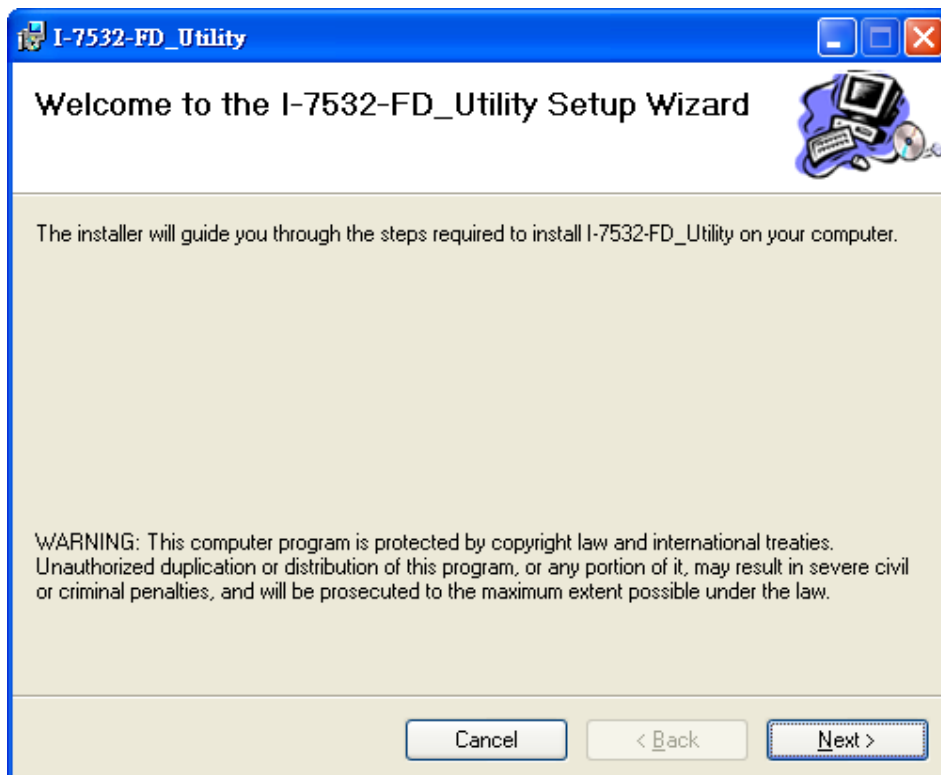

Select the installation path of the I-7532-FD Utility and click the “Next” button.

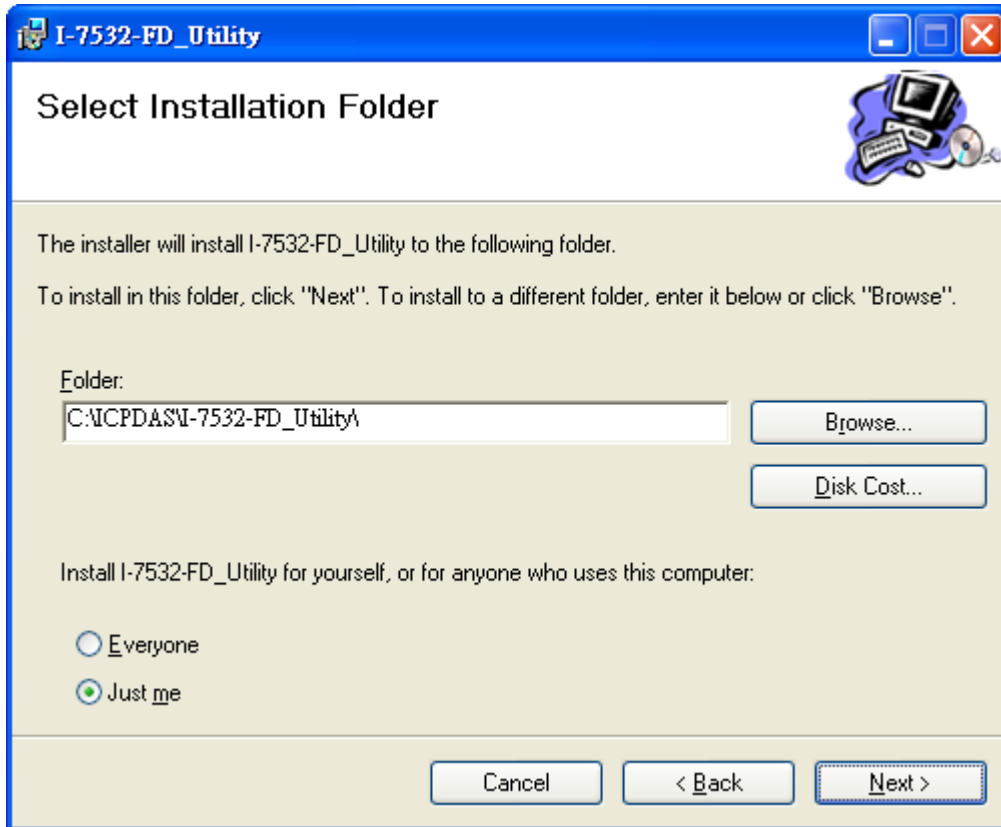

2. Confirm the installation. Click the “Next” button to start the installation

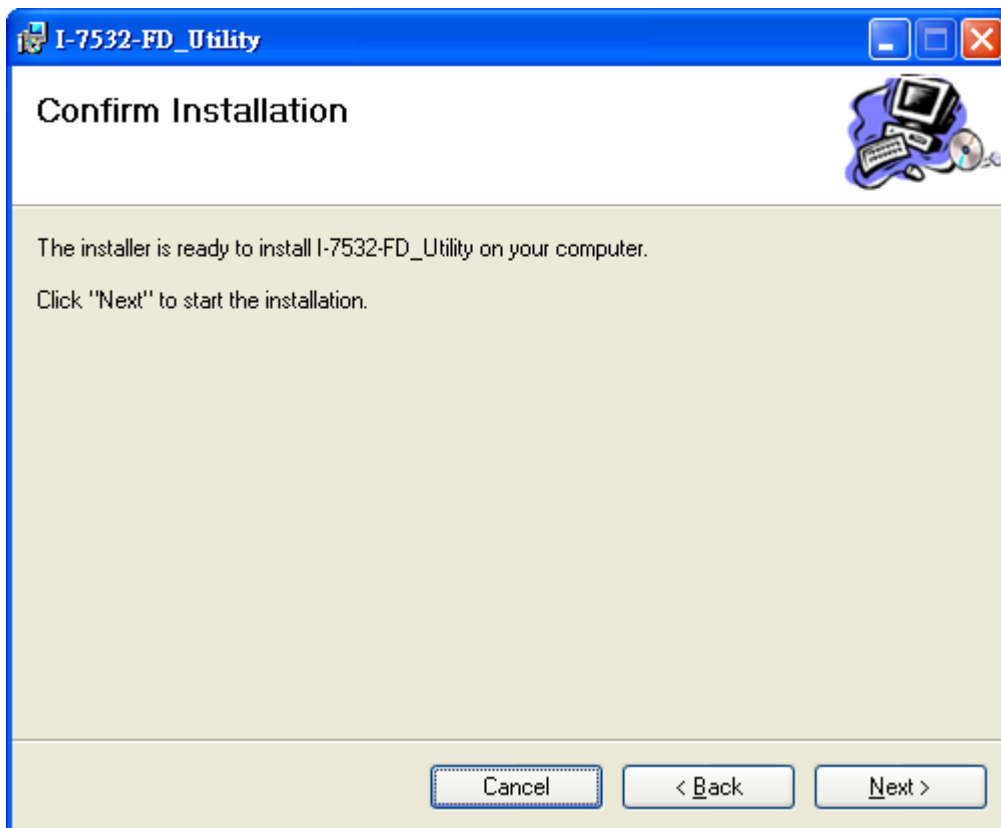

3. Installation complete. Click the “Close” button to exit

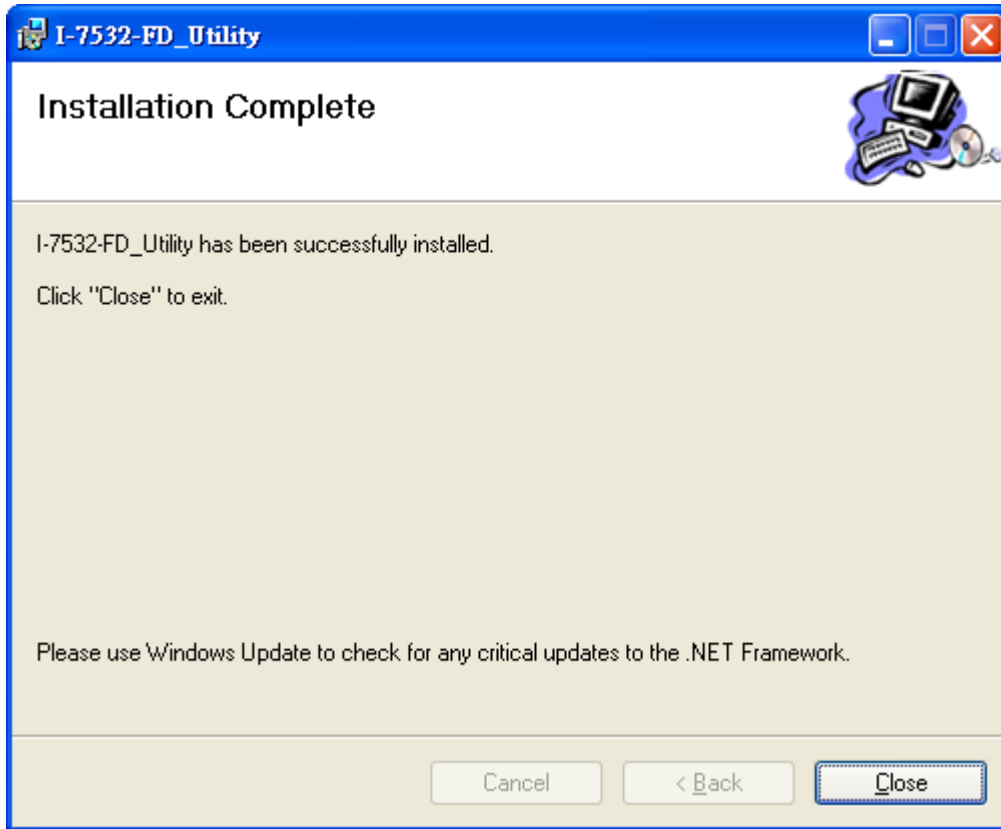

3.2. Setting up the I-7532RM-FD

After installing the utility tool, please follow the following steps to set up the communication between the Utility and the I-7532RM-FD. Here is the example for the I-7532RM-FD configuration.

Step 1: Connect the PC available USB port with the USB port of the I-7532RM-FD by using a Type C USB cable.

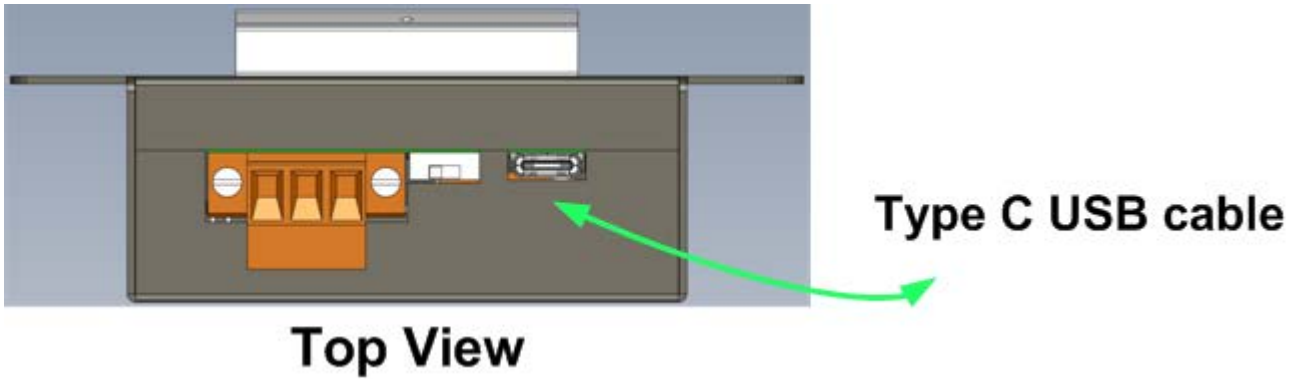

Step 2: Power On the module and execute the I-7532-FD Utility tool.

3.3. Start to use I-7532-FD Utility tool



Figure 3-3-1 Main frame of the I-7532-FD Utility tool

[Basic]

This field is used to connect to the module and get device information, get device configuration, configure device, load device configuration from file and save device configuration to file.

[CAN]

This field is used to configure the CAN controller mode, CAN FD specification, arbitration/data-phase baud rate and advanced forwarding rule.

[Filter]

This field is used to configure CAN ID filter function. Users can reject remote standard/extended CAN ID and set acceptance standard/extended CAN ID. It uses a whitelist filtering method and supports 128 groups of standard IDs and 64 groups of extended IDs per port.

[Mapping Rule]

This field is used to configure mapping rules of the device. Mapping rule is used to modify the received CAN/CAN FD frame format (including type, format, ID, data length, bit rate switch and data) from one port and then transfer it to another port. It is useful for user to change the received CAN/CAN FD format to another one. Support up to 32 mapping rules per port

[Merging Rule]

This field is used to configure merging rules of the device. Merging rule is used to combine multiple CAN frames (Max. 8) to one CAN FD frame. It is useful for user to combine multiple CAN frames data into one CAN FD frame. Support up to 32 merging rules per port.

[Splitting Rule]

This field is used to configure splitting rules of the device. Splitting rule is used to split one CAN FD frame to multiple CAN frames (Max. 8). It is useful for user to split data in one CAN FD frame to multiple CAN frames. Support up to 32 splitting rules per port.

[Status]

This field is used to check the CAN status of the device. This field is useful for user to check the device CAN network status (including no error, CAN bus off, error passive, error warning status and transmit/receive error counter information).

3.3.1. Get Device Configuration

Press the “Refresh” button to scan and list all the necessary I-7532RM-FD modules on “Module Name” location.

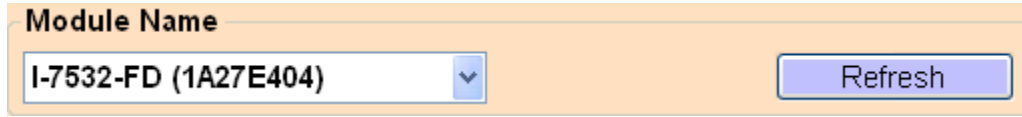

NOTE:

The module name for the I-7532M-FD and I-7532RM-FD on the utility will appear as "I-7532-FD".

Then select the necessary I-7532RM-FD module and press “Get Device Config.” button to start to connect and get device configuration.



[Get Device Config.]

This button is used to get all configuration from module. After get the module’s configuration, all the module’s parameters will be listed in “CAN”, “Filter”, “Mapping Rule”, “Merging Rule” and “Splitting Rule” fields.

[Config. Device]

This button is used to set all the settings, listed in “CAN”, “Filter”, “Mapping Rule”, “Merging Rule” and “Splitting Rule” fields, to module.

[Load Config. From File]

This button is used to get all configuration from a selected file. After load the module’s configuration from a file, all the module’s parameters will be listed in “CAN”, “Filter”, “Mapping Rule”, “Merging Rule” and “Splitting Rule” fields.

[Save Config. To File]

This button is used to save all the parameter settings, listed in “CAN”, “Filter”, “Mapping Rule”, “Merging Rule” and “Splitting Rule” fields, to a selected file.

3.3.2. CAN Bus Configuration

This field is used to configure the CAN controller mode, CAN FD specification, arbitration/data-phase baud rate and advanced forwarding rule.

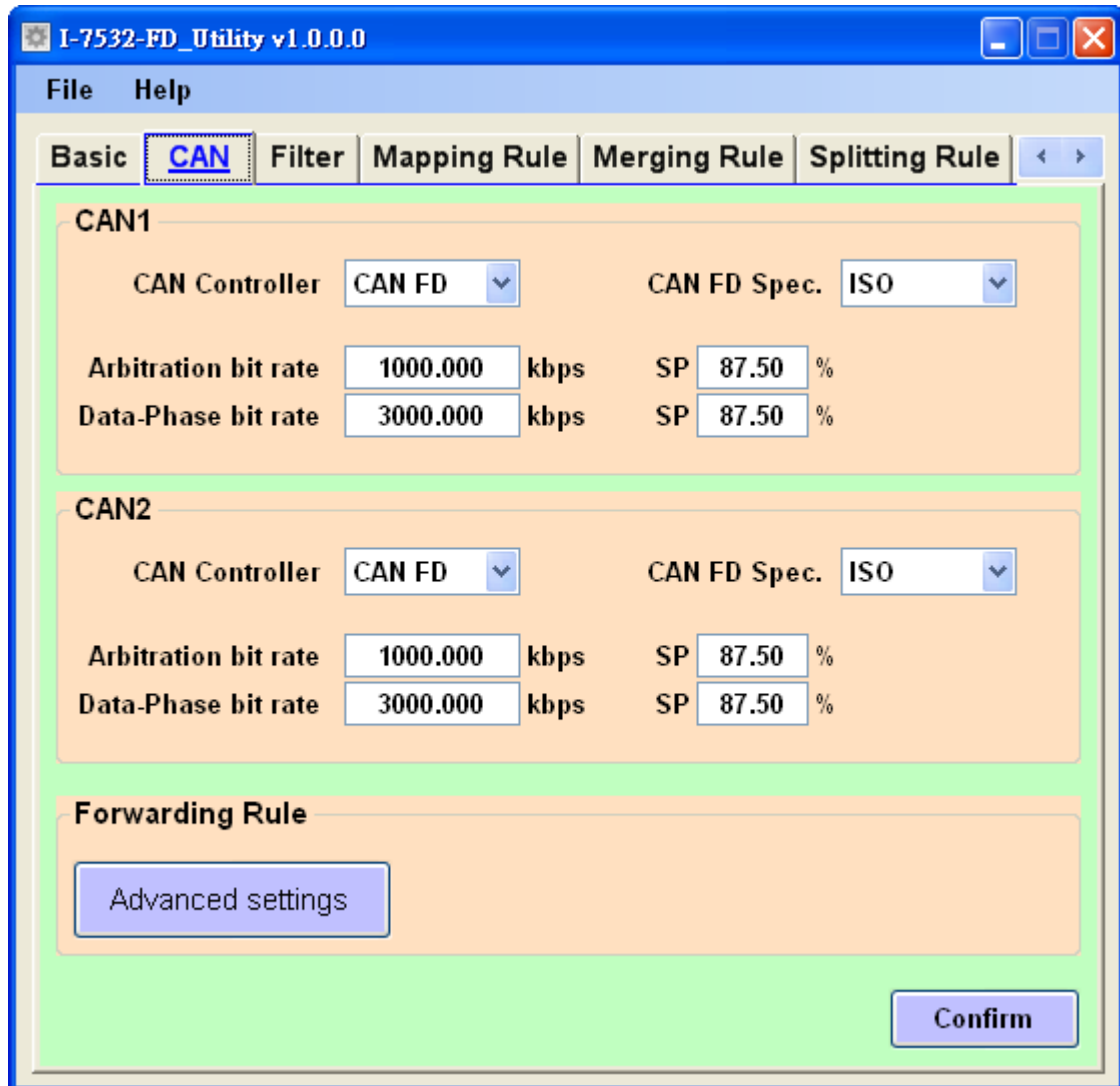

[CAN Controller]

Set the CAN port into CAN or CAN FD mode. When setting the CAN port into CAN FD mode, the CAN port can process CAN/CAN FD frames, otherwise this port just can process CAN frame.

[CAN FD Spec.]

Set the CAN FD frame of the CAN port follows ISO or Non-ISO specification. For “ISO” specification setting, the module uses the CAN FD frame format as specified by the ISO11898-1. For “Non-ISO” specification setting, the module uses the CAN FD frame format as specified by Bosch CAN FD Specification V1.0.

[Arbitration bit rate]

CAN/CAN FD arbitration phase bit rate. Valid range: 10 kbps ~ 1000 kbps.

[Data phase bit rate]

CAN FD data phase bit rate. Valid range: 100 kbps ~ 10000 kbps

[SP]

CAN/CAN FD arbitration/data phase bit rate sample point.

Suggested range: 75.00 ~ 87.50 %

[Forwarding Rule → Advanced settings]

Dependent on CAN controller setting, the forwarding rule may be different. The following table list the default forwarding rule setting. User can change the default forwarding rule on “Advanced setting” frame.

Rx CAN Controller	Tx CAN Controller	Rx CAN → CAN	Rx CAN → CAN FD	Rx CAN FD → CAN	Rx CAN FD → CAN FD
CAN	CAN	Default	No effect	No effect	No effect
CAN	CAN FD	User can set	Default	No effect	No effect
CAN FD	CAN	Default	No effect	Default	No effect
CAN FD	CAN FD	Default	User can set	User can set	Default

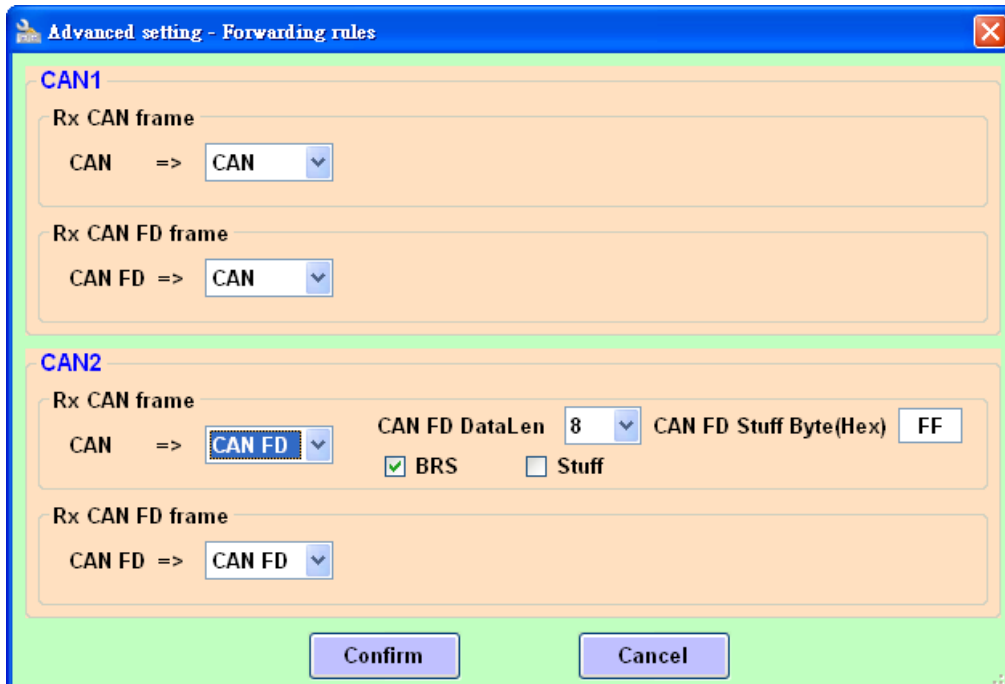

Advanced setting:

- Can set “Rx CAN => CAN”, “Rx CAN FD => CAN”, “Rx CAN => CAN FD” and “Rx CAN FD => CAN FD”.

- When setting “Rx CAN => CAN” or “Rx CAN FD => CAN FD”, CAN or CAN FD frame will be no changed when sent out to another port.
- When setting “Rx CAN FD => CAN”, CAN FD frame with large than 8 bytes data will be cut off and only keep 8 bytes data.
- When setting “Rx CAN => CAN FD”:
 - When no checking “Stuff” item, data field of received CAN frame be no changed and transform to CAN FD frame.
 - When checking “Stuff” item, received CAN frame (data length equal to 8) will be transformed and stuffed with “stuff byte” value ; received CAN frame (data length: 0 ~ 7) will be no changed and transform to CAN FD frame.
 - Can set CAN FD frame with “BRS” (bit rate switch) or not.

3.3.2.1. Forwarding Rule Examples

1. "Rx CAN => CAN"

Rx CAN frame

CAN => CAN

Set CAN1 "Rx CAN => CAN". Received CAN frame on port 1 will be no change and transfer to port 2.

Frame on CAN network (port 1)

port	Direction	CAN type	ID	Frame type	Frame format	Datalen	Data
1	Rx	CAN	0x111	standard	data	8	00-11-22-33-44-55-66-77

Frame on CAN network (port 2)

port	Direction	CAN type	ID	Frame type	Frame format	Datalen	Data
2	Tx	CAN	0x111	standard	data	8	00-11-22-33-44-55-66-77

2. "Rx CAN FD => CAN"

Rx CAN FD frame

CAN FD => CAN

Set CAN1 "Rx CAN FD => CAN". CAN FD with data length large than 8 will be cut off and only keep 8 bytes data

Frame on CAN network (port 1)

port	Direction	CAN type	ID	Frame type	Frame format	Datalen	Data
1	Rx	CAN FD	0x111	standard	data	64	00-11-22-33-44-55-66-77 00-00-00-00-00 ...

Frame on CAN network (port 2)

port	Direction	CAN type	ID	Frame type	Frame format	Datalen	Data
2	Tx	CAN	0x111	standard	data	8	00-11-22-33-44-55-66-77

3. “Rx CAN => CAN FD”

Set CAN2 “Rx CAN => CAN FD”. When receiving a CAN frame with data length equal to 8, this frame will be transformed to a CAN FD frame with data length 16, stuff with 0xFF and enable BRS.

Frame on CAN network (port 2)

port	Direction	CAN type	ID	Frame type	Frame format	Datalen	Data
2	Rx	CAN	0x111	standard	data	8	00-11-22-33-44-55-66-77

Frame on CAN network (port 1)

port	Direction	CAN type	ID	Frame type	Frame format	Datalen	Data
1	Tx	CAN FD	0x111	standard	data + BRS	16	00-11-22-33-44-55-66-77- FF-FF-FF-FF-FF-FF-FF-FF

4. “Rx CAN FD => CAN FD”

Set CAN2 “Rx CAN FD => CAN FD”. Received CAN FD frame on port 2 will be no change and transfer to port 1.

Frame on CAN network (port 2)

port	Direction	CAN type	ID	Frame type	Frame format	Datalen	Data
2	Rx	CAN FD	0x111	standard	Data+BRS	16	00-11-22-33-44-55-66-77- 88-99-AA-BB-CC-DD-EE-FF

Frame on CAN network (port 1)

port	Direction	CAN type	ID	Frame type	Frame format	Datalen	Data
1	Tx	CAN FD	0x111	standard	Data+BRS	16	00-11-22-33-44-55-66-77- 88-99-AA-BB-CC-DD-EE-FF

3.3.3. CAN Filter Configuration

This field is used to configure CAN ID filter function. Users can reject remote standard/extended CAN ID and set acceptance standard/extended CAN ID. It uses a whitelist filtering method and supports 128 groups of standard IDs and 64 groups of extended IDs per port.

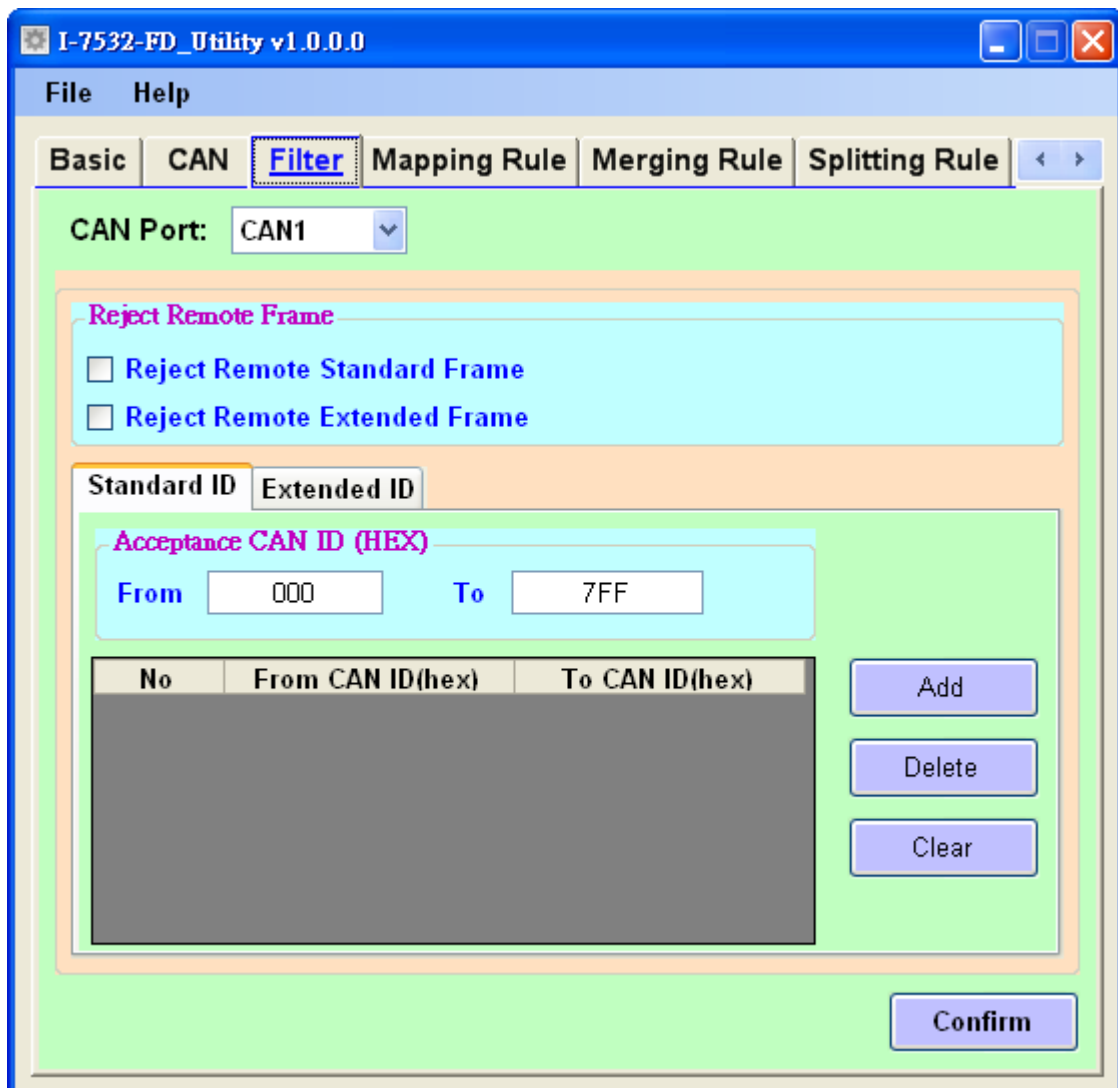

The “Reject Remote Frame” is used to reject remote standard/extended frame. And the “Standard ID/Extended ID” field is used to set accepted standard/extended CAN IDs (using white-list rule). The CAN1/CAN2 filter settings will take effect after press the confirm button.

[Reject Remote Frame] block:



Click the “Reject Remote Standard/Extended Frame” item to select whether to reject remote standard/extended CAN frame or not

[Standard ID/Extended ID] block:

Standard ID Extended ID

Acceptance CAN ID (HEX)

From 000 To 7FF

No	From CAN ID(hex)	To CAN ID(hex)
----	------------------	----------------

Add

Delete

Clear

Press the “Add”, “Delete” button to add/delete a range of standard/extended CAN ID into filter frame.

3.3.4. CAN Mapping Rule Configuration

This field is used to configure mapping rules of the device. Mapping rule is used to modify the received CAN/CAN FD frame format (including type, format, ID, data length, bit rate switch and data) from one port and then transfer it to another port. It is useful for user to change the received CAN/CAN FD format to another one. Each port maximum supports 32 mapping rules.

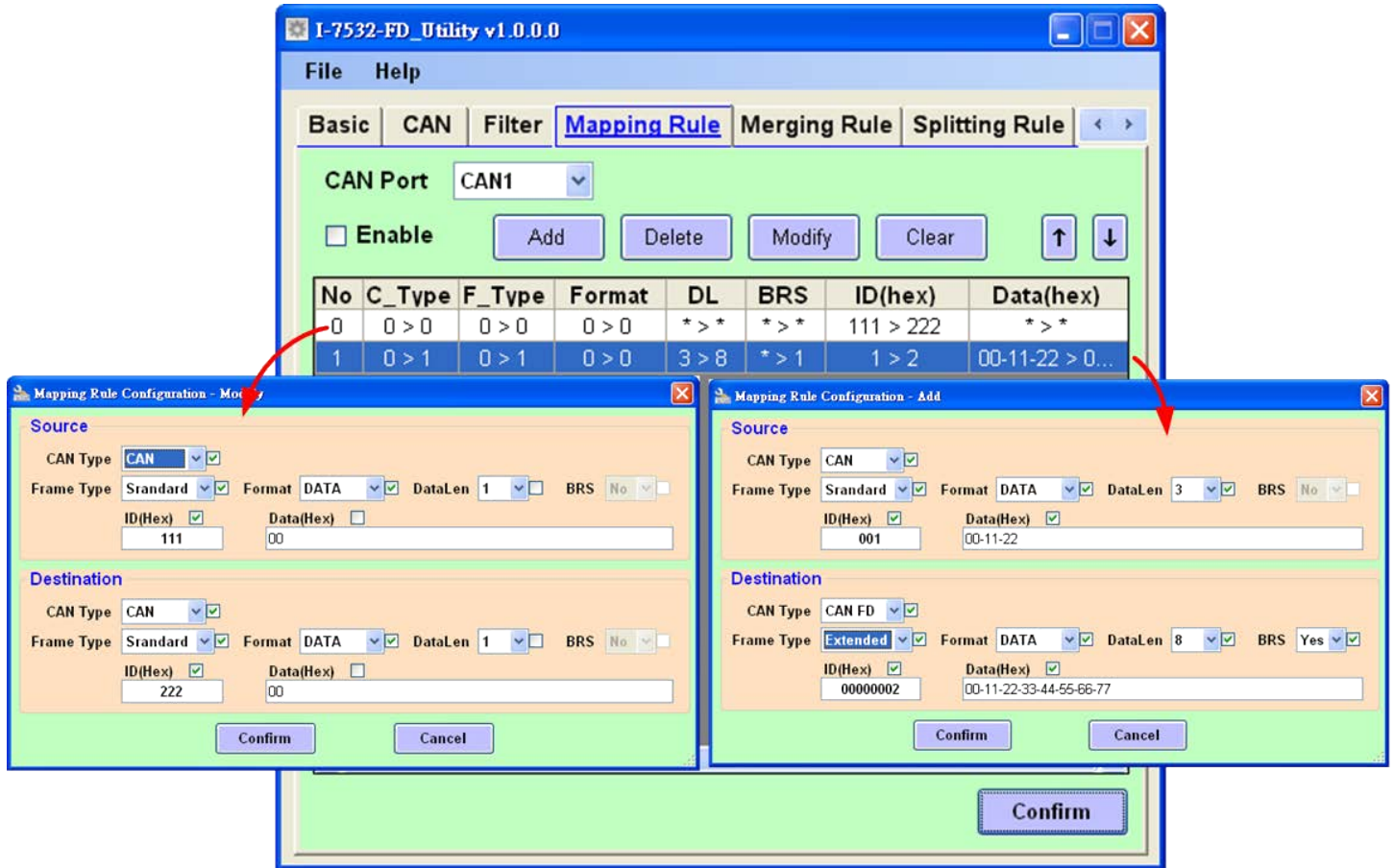

[Enable]

Enable or disable mapping rule function of this CAN port.

[No]

Rule number. Maximum support 32 mapping rules per port. The smaller the number, the higher the process priority level.

[C_Type]

CAN or CAN FD frame type.

0: CAN frame, 1: CAN FD frame. *: no check.

[F_Type]

Standard or extended frame type

0: standard frame, 1: extended frame. *: no check.

[Format]

Data or remote frame format

0: data frame, 1: remote frame. *: no check.

[DL]

Data length

0~8: CAN frame data length, 0~64: CAN FD frame data length. *: no check.

[BRS]

Bit rate switch or not

0: not use bit rate switch, 1: use bit rate switch. *: no check.

[ID]

ID field of CAN/CAN FD frame

*: no check.

[Data(hex)]

Data field of CAN/CAN FD frame

*: no check.

After press “Add” or “Modify” button, users can set the mapping rule parameters on “Mapping Rule Configuration” frame.

The screenshot shows a dialog box titled "Mapping Rule Configuration - Add". It is divided into two main sections: "Source" and "Destination".

Source Section:

- CAN Type: CAN (checked)
- Frame Type: Standard (checked)
- Format: DATA (checked)
- DataLen: 1 (checked)
- BRS: No
- ID(Hex): (value: 0)
- Data(Hex): (value: 00)

Destination Section:

- CAN Type: CAN (checked)
- Frame Type: Standard (checked)
- Format: DATA (checked)
- DataLen: 1 (checked)
- BRS: No
- ID(Hex): (value: 0)
- Data(Hex): (value: 00)

At the bottom of the dialog are two buttons: "Confirm" and "Cancel".

- Mapping rule supports mapping frame via “CAN Type”, “Frame Type”, “Format”, “DataLen”, “BRS”, “ID” and “Data”. User can select the necessary items via checking the checkbox of the item. In “Source ” field, checked items will be compared with the set value. In “Destination” field, checked items will be modified with the set value.

3.3.4.1. Mapping Rule Examples

1. Not map data field of received CAN frame.

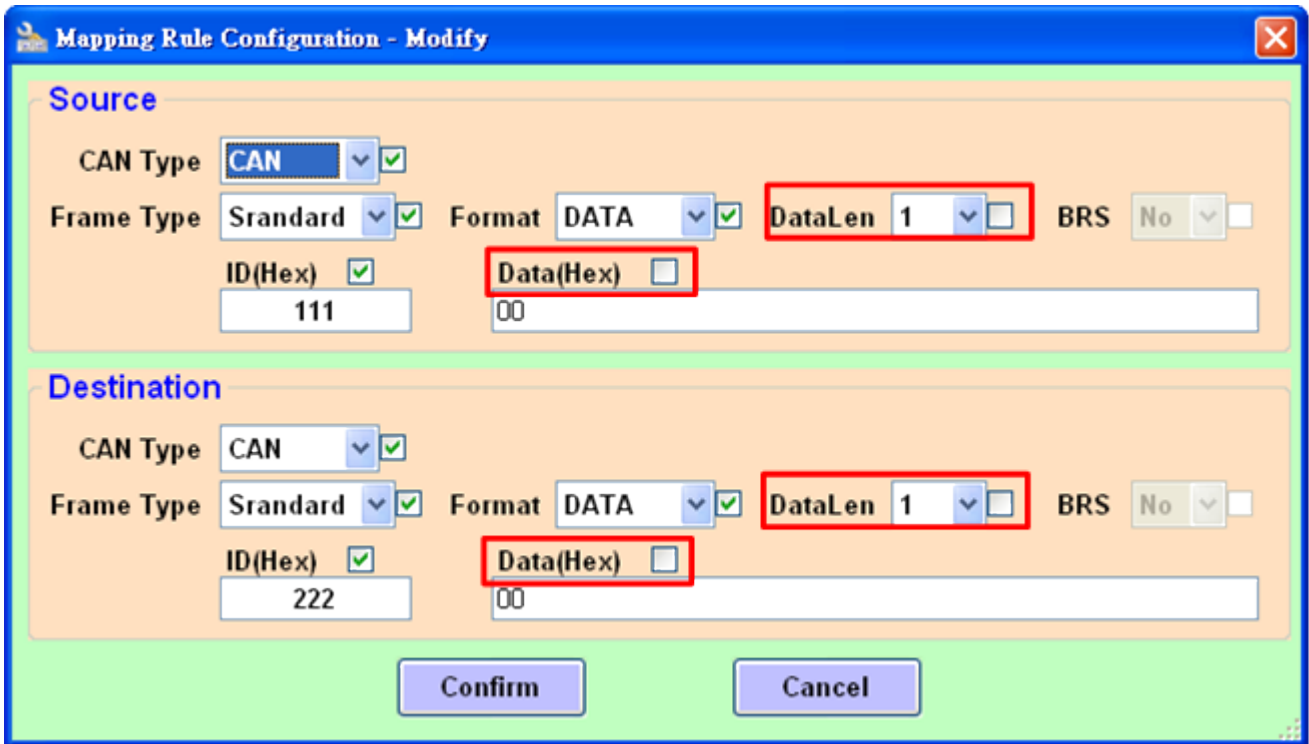

Receive CAN standard ID: 0x111 on port 1 and transform it to port 2 with CAN standard ID: 0x222. No check and modify the data length and data field.

Frame on CAN network (port 1)

port	Direction	CAN type	ID	Frame type	Frame format	Datalen	Data
1	Rx	CAN	0x111	standard	data	8	00-11-22-33-44-55-66-77

Frame on CAN network (port 2)

port	Direction	CAN type	ID	Frame type	Frame format	Datalen	Data
2	Tx	CAN	0x222	standard	data	8	00-11-22-33-44-55-66-77

2. Map data field of received CAN frame.

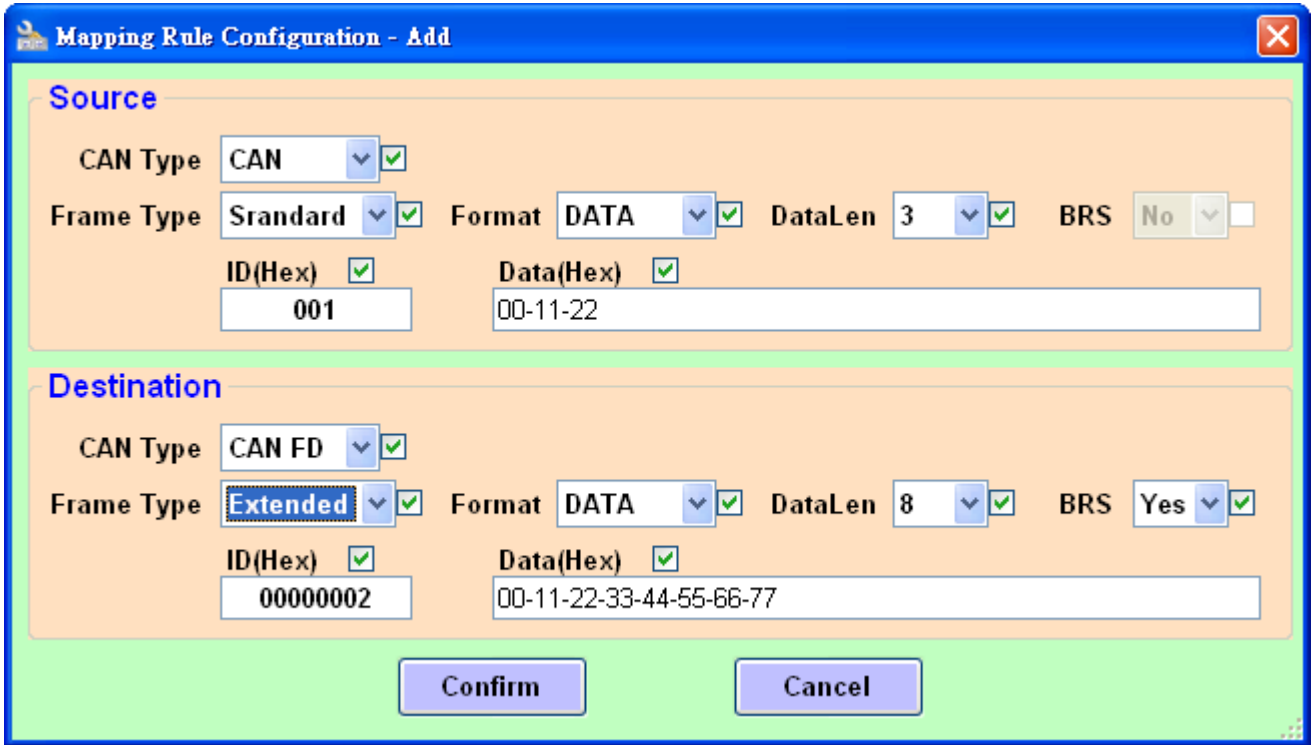

Receive CAN standard ID: 0x001, DataLen: 0x3 and Data: 00-01-02 on port 1 and transform it to port 2 with CAN FD extended ID: 0x00000002, DataLen: 0x8, Data: 00-11-22-33-44-55-66-77 and enable bit rate switch.

Frame on CAN network (port 1)

port	Direction	CAN type	ID	Frame type	Frame format	Datalen	Data
1	Rx	CAN	0x001	standard	data	3	00-11-22

Frame on CAN network (port 2)

port	Direction	CAN type	ID	Frame type	Frame format	Datalen	Data
2	Tx	CAN FD	0x00000002	extended	data + BRS	8	00-11-22-33-44-55-66-77

3.3.5. CAN Merging Rule Configuration

This field is used to configure merging rules of the device. Merging rule is used to combine multiple CAN frames (Max. 8) to one CAN FD frame. It is useful for user to combine multiple CAN frames data into one CAN FD frame. Each port maximum supports 32 merging rules.

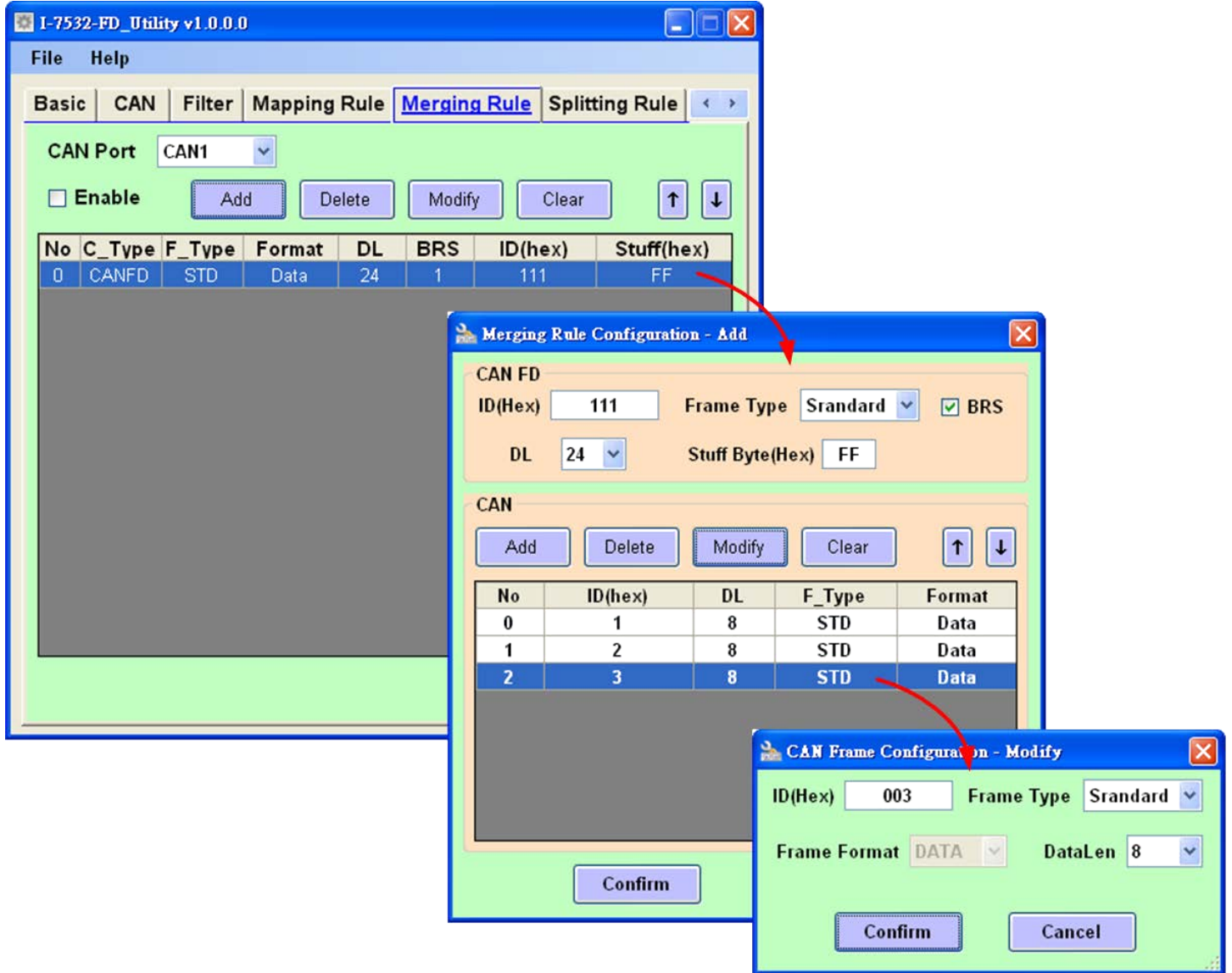

The merging rule field is similar to mapping rule field. After setting the rules on “Merging Rule Configuration” frame, rules will be displayed on the frame list. The smaller the number of “No”, the higher the process priority. User can press the “Add” button to add a new rule or press the “Modify” button to modify the selected rule.

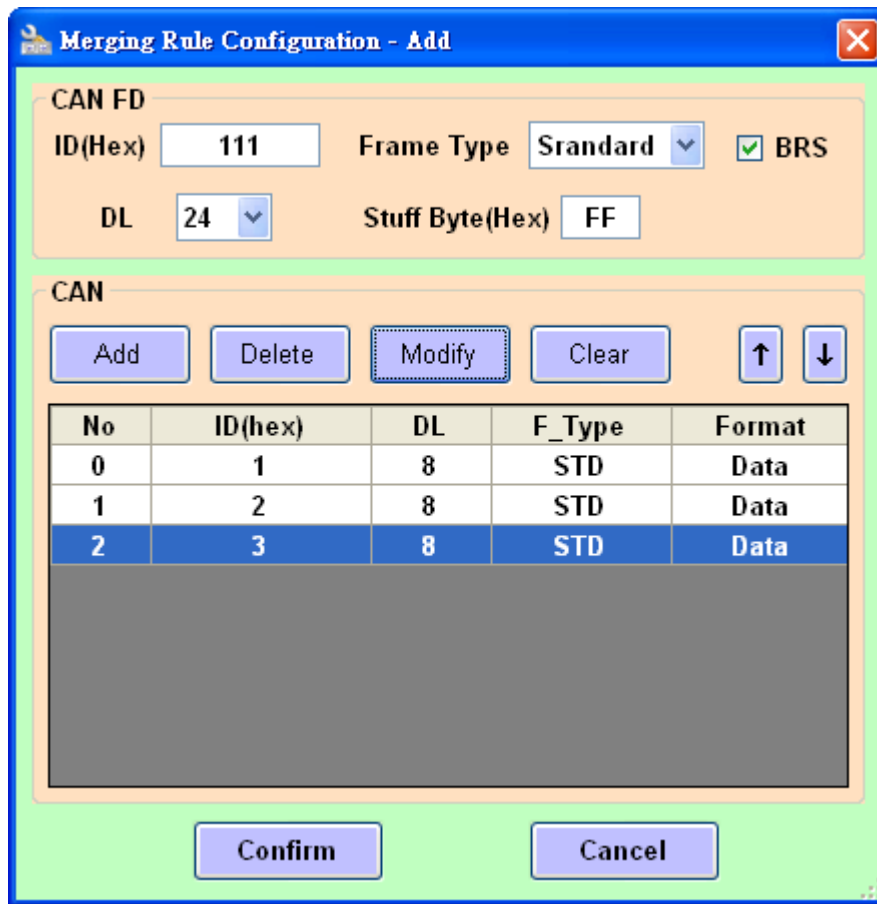

- The CAN FD frame will be sent out when receiving the latest “No” of CAN frame. All received CAN frames data in the CAN list will be combined to the data field of the CAN FD frame.
- Each merging rule maximum support merging 8 CAN frames to one CAN FD frame, and the total data length of these CAN frames cannot large than the CAN FD frame “DL” value.
- In the same merging rule, each CAN frames IDs are different to each other.
- The “Stuff Byte” value will be stuffed into CAN FD frame data field when the sum of all CAN frames data length is less than the CAN FD frame “DL” value.

3.3.5.1. Merging Rule Examples

1. Merge three CAN frames to one CAN FD frame

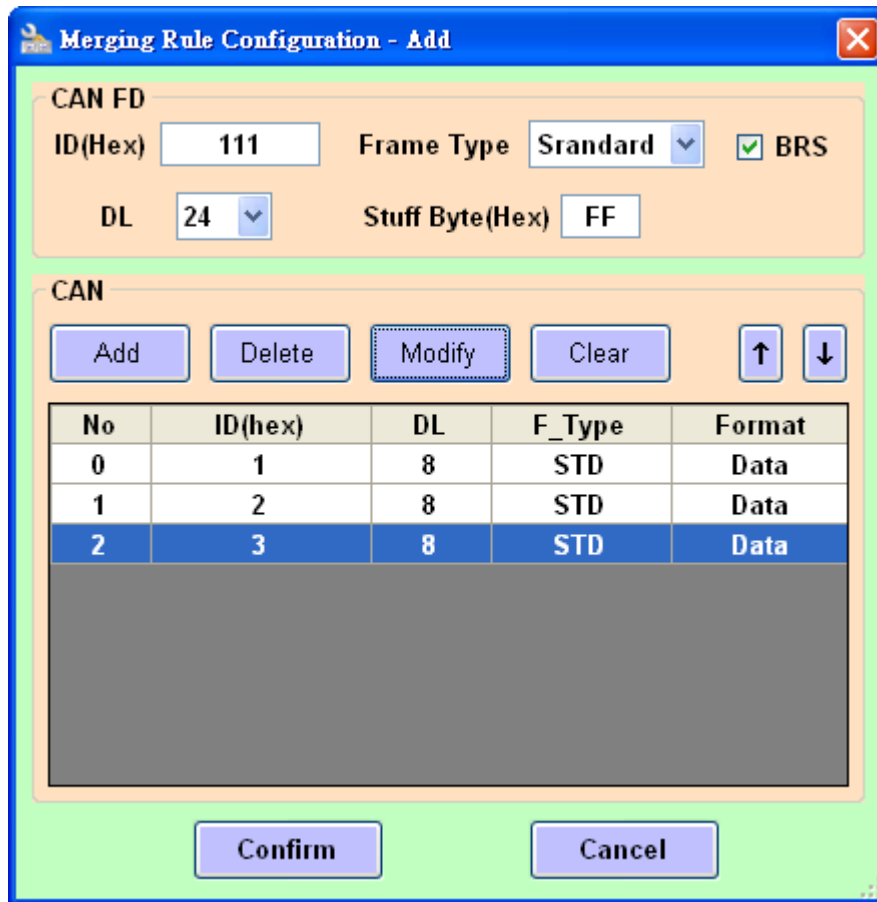

Merge three CAN frames (ID: 0x001, 0x002, 0x003, DL: 8) on port 1 to one CAN FD frame (ID: 0x111, DL: 24). After receiving the CAN frame of ID: 0x003, the converted CAN FD frame will be send out to port 2.

Frame on CAN network (port 1)

port	Direction	CAN type	ID	Frame type	Frame format	Datalen	Data
1	Rx	CAN	0x001	standard	data	8	00-01-02-03-04-05-06-07
1	Rx	CAN	0x002	standard	data	8	08-09-0A-0B-0C-0D-0E-0F
1	Rx	CAN	0x003	standard	data	8	10-11-12-13-14-15-16-17

Frame on CAN network (port 2)

port	Direction	CAN type	ID	Frame type	Frame format	Datalen	Data
2	Tx	CAN FD	0x111	standard	Data + BRS	24	00-01-02-03-04-05-06-07- 08-09-0A-0B-0C-0D-0E-0F- 10-11-12-13-14-15-16-17

2. Merge three CAN frames to one CAN FD frame (with “Stuff Byte”)

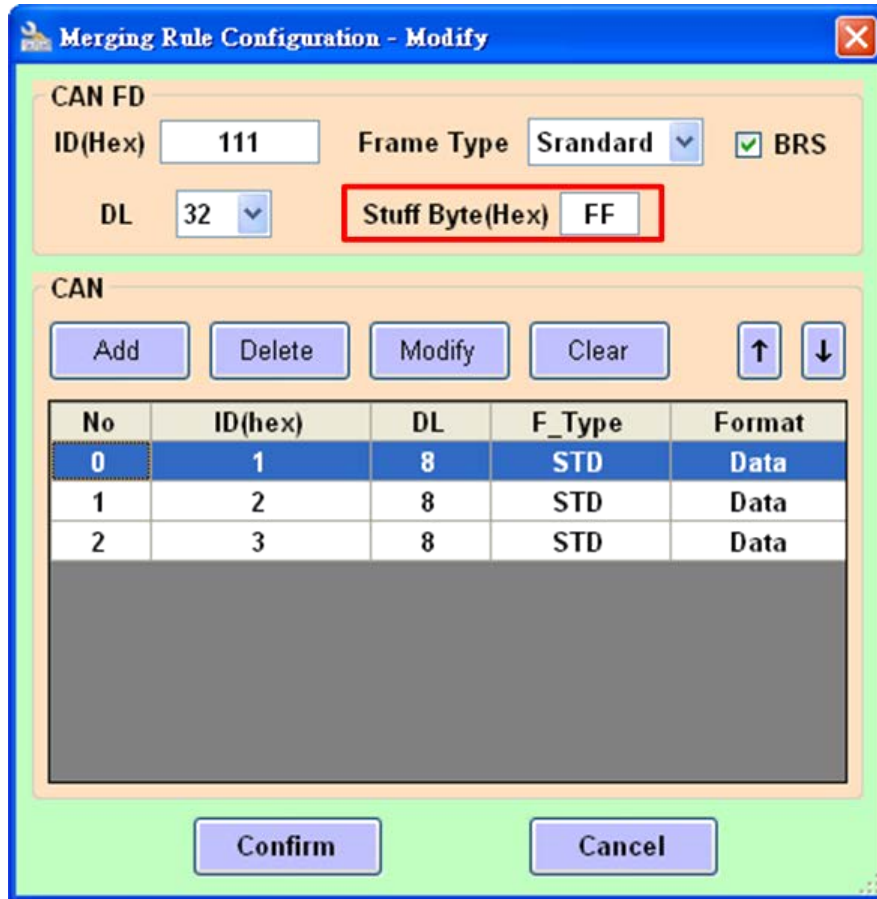

Merge three CAN frames (ID: 0x001, 0x002, 0x003, DL: 8) on port 1 to one CAN FD frame (ID: 0x111, DL: 32) stuffed with “Stuff Byte” : 0xFF. After receiving the CAN frame of ID: 0x003, the converted CAN FD frame will be send out to port 2.

Frame on CAN network (port 1)

port	Direction	CAN type	ID	Frame type	Frame format	Datalen	Data
1	Rx	CAN	0x001	standard	data	8	00-01-02-03-04-05-06-07
1	Rx	CAN	0x002	standard	data	8	08-09-0A-0B-0C-0D-0E-0F
1	Rx	CAN	0x003	standard	data	8	10-11-12-13-14-15-16-17

Frame on CAN network (port 2)

port	Direction	CAN type	ID	Frame type	Frame format	Datalen	Data
2	Tx	CAN FD	0x111	standard	Data + BRS	32	00-01-02-03-04-05-06-07- 08-09-0A-0B-0C-0D-0E-0F- 10-11-12-13-14-15-16-17- FF-FF-FF-FF-FF-FF-FF-FF

3.3.6. CAN Splitting Rule Configuration

This field is used to configure splitting rules of the device. Splitting rule is used to split one CAN FD frame to multiple CAN frames (Max. 8). It is useful for user to split data in one CAN FD frame to multiple CAN frames. Each port maximum supports 32 splitting rules.

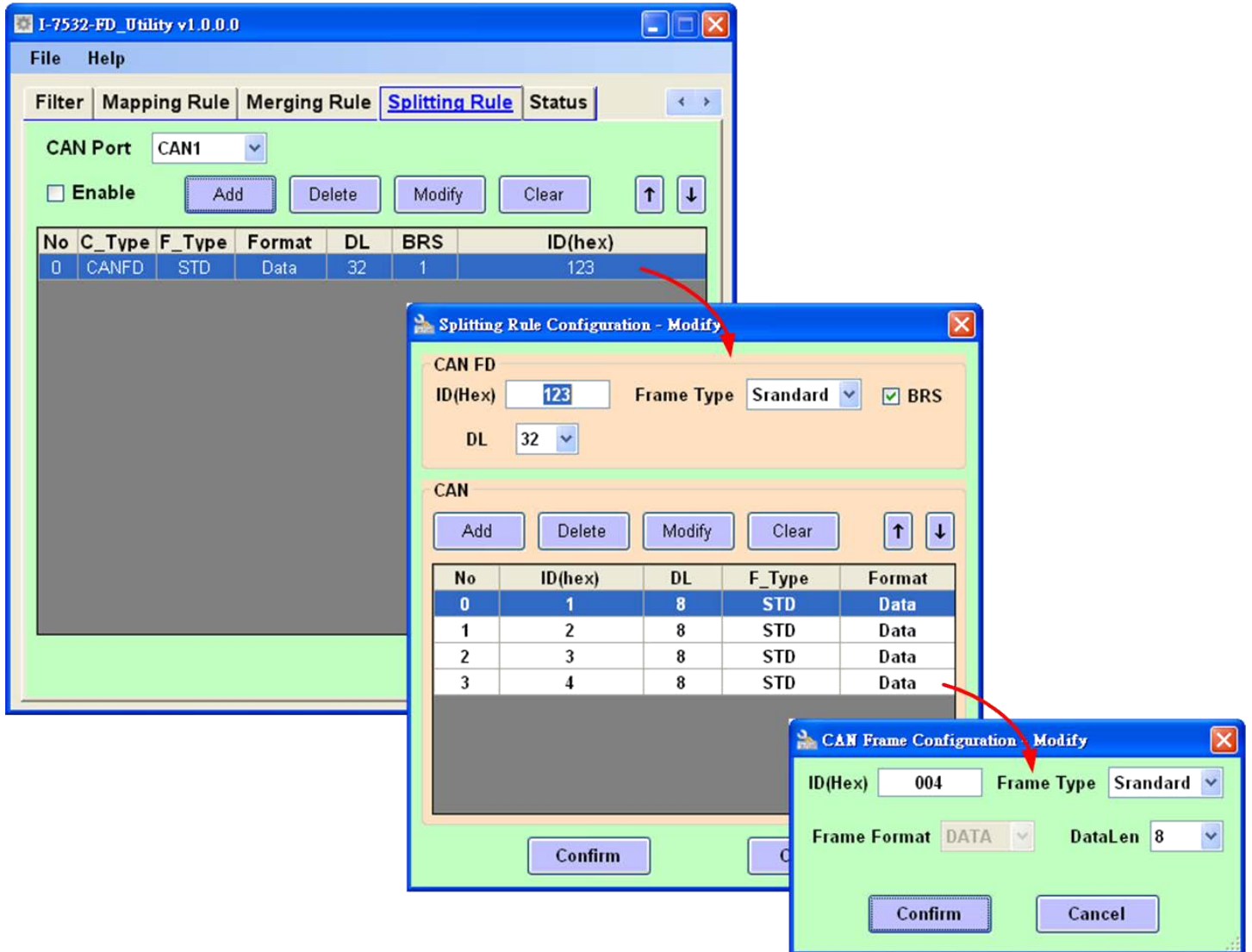

The splitting rule field is similar to merging rule field. After setting the rules on “Splitting Rule Configuration” frame, rules will be displayed on the frame list. The smaller the “No” number, the higher the process priority level. User can press the “Add” button to add a new rule or press the “Modify” button to modify the selected rule.

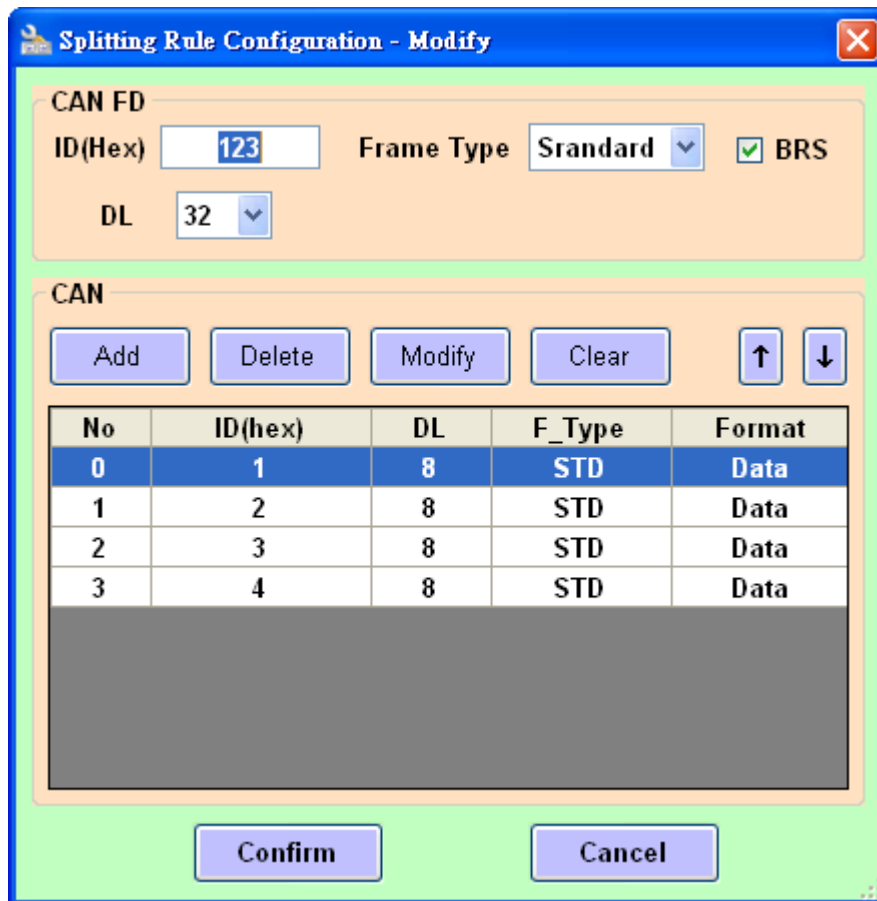

- Each splitting rule maximum support one CAN FD frame splitting to 8 CAN frames, and the total data length of these CAN frames cannot large than the CAN FD frame “DL” value.
- In the same splitting rule, each CAN frames IDs are different to each other.

3.3.6.1. Splitting Rule Examples

1. Split one CAN FD frame to four CAN frames.

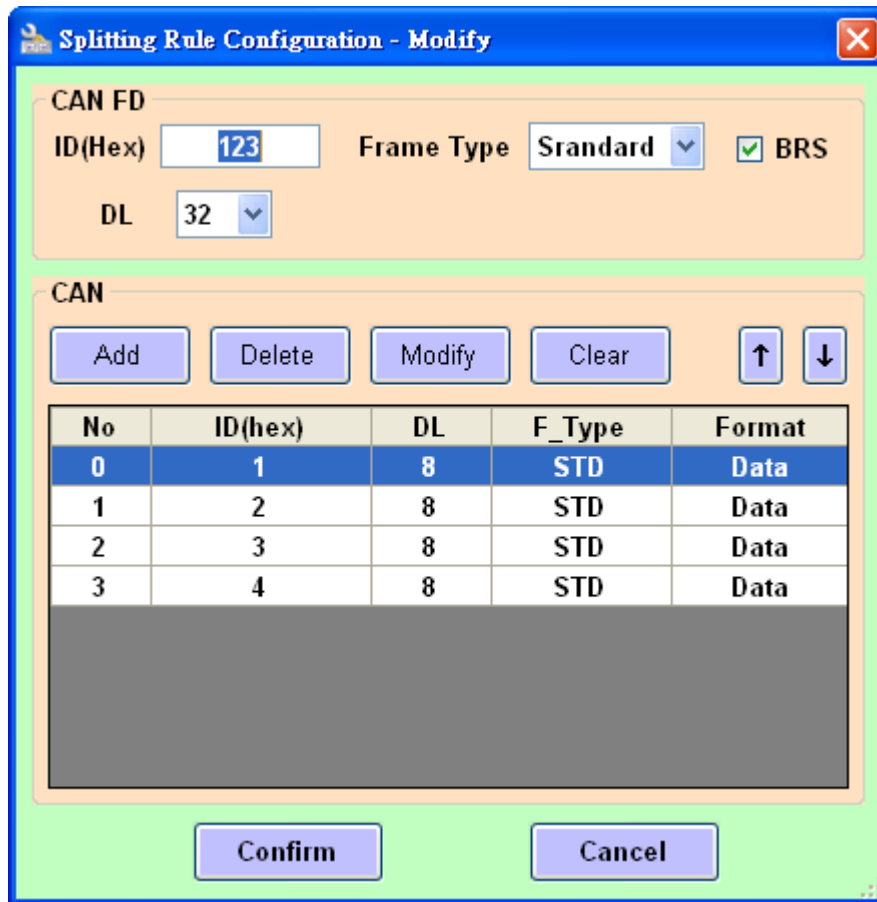

When receiving the CAN FD frame (standard ID: 0x123, DL: 32, BRS enable) on port 1, this frame will be splitted into four CAN frames (standard ID: 0x001, 0x002, 0x003, 0x004) with 8 bytes data and sent out to port 2.

Frame on CAN network (port 1)

port	Direction	CAN type	ID	Frame type	Frame format	Datalen	Data
1	Rx	CAN FD	0x123	standard	Data + BRS	32	00-01-02-03-04-05-06-07-08-09-0A-0B-0C-0D-0E-0F-10-11-12-13-14-15-16-17-18-19-1A-1B-1C-1D-1E-1F

Frame on CAN network (port 2)

port	Direction	CAN type	ID	Frame type	Frame format	Datalen	Data
2	Tx	CAN	0x001	standard	data	8	00-01-02-03-04-05-06-07
2	Tx	CAN	0x002	standard	data	8	08-09-0A-0B-0C-0D-0E-0F
2	Tx	CAN	0x003	standard	data	8	10-11-12-13-14-15-16-17
2	Tx	CAN	0x004	standard	data	8	18-19-1A-1B-1C-1D-1E-1F

2. Split one CAN FD frame to three CAN frames. (throw away four bytes data)

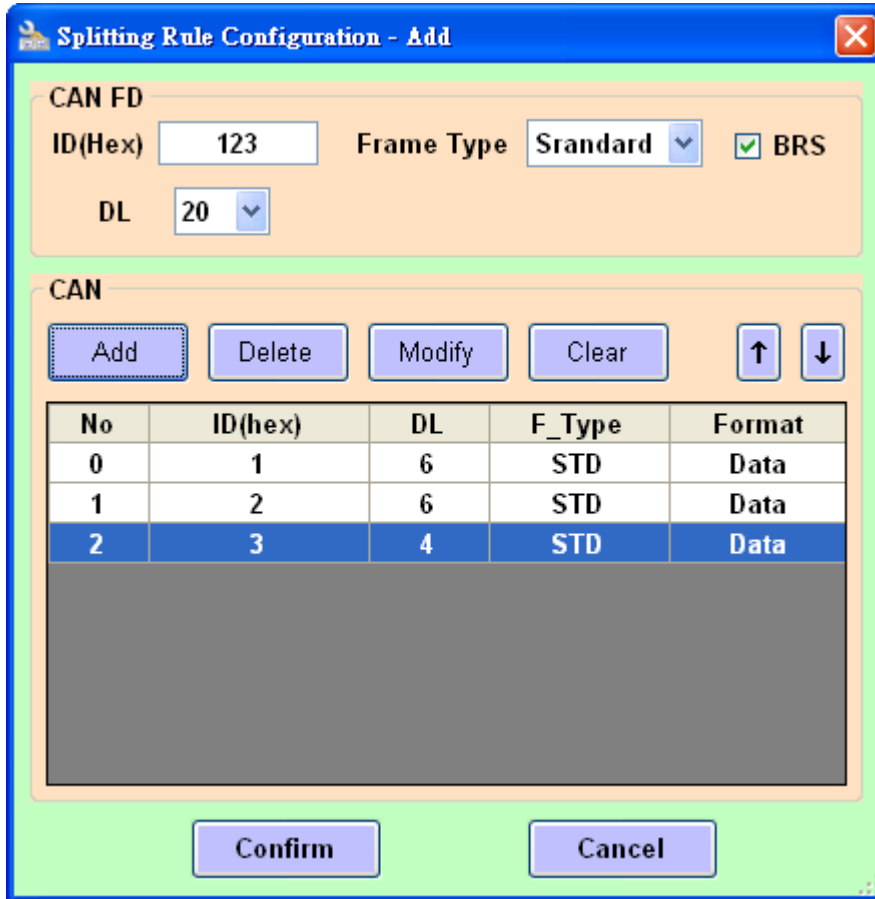

When receiving the CAN FD frame (standard ID: 0x123, DL: 20, BRS enable) on port 1, this frame will be splitted into three CAN frames (standard ID: 0x001, 0x002, 0x003) with 6/6/4 bytes data and sent out to port 2. The latest four bytes data of CAN FD frame will be throw away.

Frame on CAN network (port 1)

port	Direction	CAN type	ID	Frame type	Frame format	Datalen	Data
1	Rx	CAN FD	0x123	standard	Data + BRS	20	00-01-02-03-04-05-06-07-08-09-0A-0B-0C-0D-0E-0F-10-11-12-13

Frame on CAN network (port 2)

port	Direction	CAN type	ID	Frame type	Frame format	Datalen	Data
2	Tx	CAN	0x001	standard	data	6	00-01-02-03-04-05
2	Tx	CAN	0x002	standard	data	6	06-07-08-09-0A-0B
2	Tx	CAN	0x003	standard	data	4	0C-0D-0E-0F

3.3.7. CAN Status Information

This field is used to check the CAN status of the device. This field is useful for user to check the device CAN network status (including no error, bus off, error passive, error warning status and transmit/receive error counter information) .

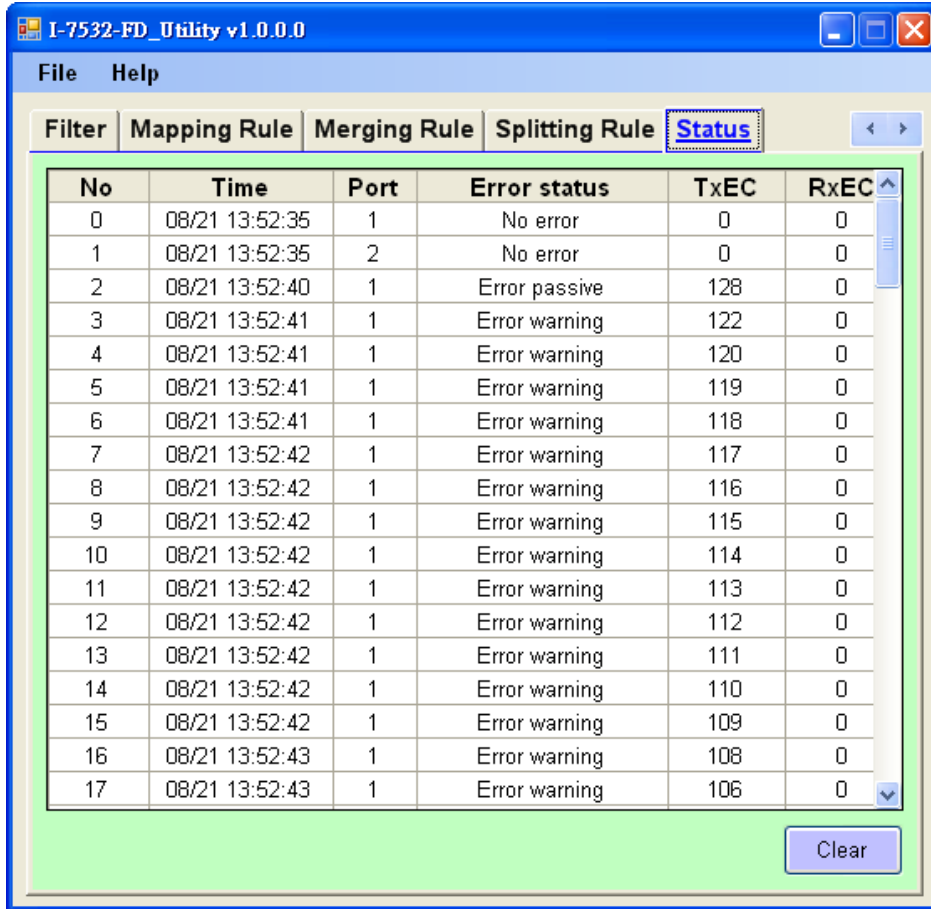

The screenshot shows a software window titled "I-7532-FD_Utility v1.0.0.0" with a menu bar containing "File" and "Help". Below the menu bar is a tabbed interface with tabs for "Filter", "Mapping Rule", "Merging Rule", "Splitting Rule", and "Status". The "Status" tab is active and displays a table with the following data:

No	Time	Port	Error status	TxEC	RxEC
0	08/21 13:52:35	1	No error	0	0
1	08/21 13:52:35	2	No error	0	0
2	08/21 13:52:40	1	Error passive	128	0
3	08/21 13:52:41	1	Error warning	122	0
4	08/21 13:52:41	1	Error warning	120	0
5	08/21 13:52:41	1	Error warning	119	0
6	08/21 13:52:41	1	Error warning	118	0
7	08/21 13:52:42	1	Error warning	117	0
8	08/21 13:52:42	1	Error warning	116	0
9	08/21 13:52:42	1	Error warning	115	0
10	08/21 13:52:42	1	Error warning	114	0
11	08/21 13:52:42	1	Error warning	113	0
12	08/21 13:52:42	1	Error warning	112	0
13	08/21 13:52:42	1	Error warning	111	0
14	08/21 13:52:42	1	Error warning	110	0
15	08/21 13:52:42	1	Error warning	109	0
16	08/21 13:52:43	1	Error warning	108	0
17	08/21 13:52:43	1	Error warning	106	0

At the bottom right of the table area, there is a "Clear" button.

[Time]

The local time of the PC which running the Utility tool.

[Error status]

CAN network status of the device CAN port, including no error, CAN bus off, error passive, error warning status.

[TxEC]

Transmit error counter of the device CAN port Current value of the transmit error counter.

[RxEC]

Receive error counter of the device CAN port. Current value of the receive error counter.

4. Firmware Upgrade

Please refer to the following steps to upgrade the firmware of I-7532RM-FD module.

Step 1: Power off the I-7532RM-FD.

Step 2: Set the Init. dip switch to 'ON' position.

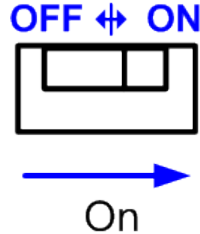

Step 3: Power on the I-7532RM-FD, the red and green led of USB, CAN1 and CAN2 will polling to flash per 200 milliseconds.

Step 4: Connect the PC available USB port with the USB port of the I-7532RM-FD by using a Type C USB cable.

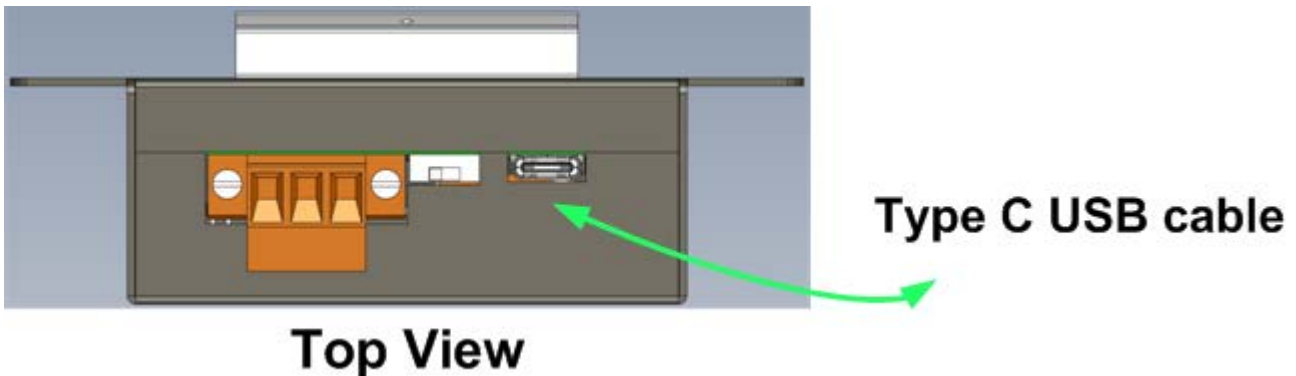

Step 5: At this time, the I-7532RM-FD module will be simulated as a “USB Mass Storage Device”, and one more “USB Disk” window, will pop up on the PC side. Then users can upgrade the firmware of the I-7532RM-FD module via this USB disk.

Step 6: Get the “Firmware Update Tool” and firmware file.

The “Firmware Update Tool” is located at:

[Firmware Update Tool](#)

The firmware is located at:

[Firmware](#)

Step 7: Execute the “Firmware Update Tool”.

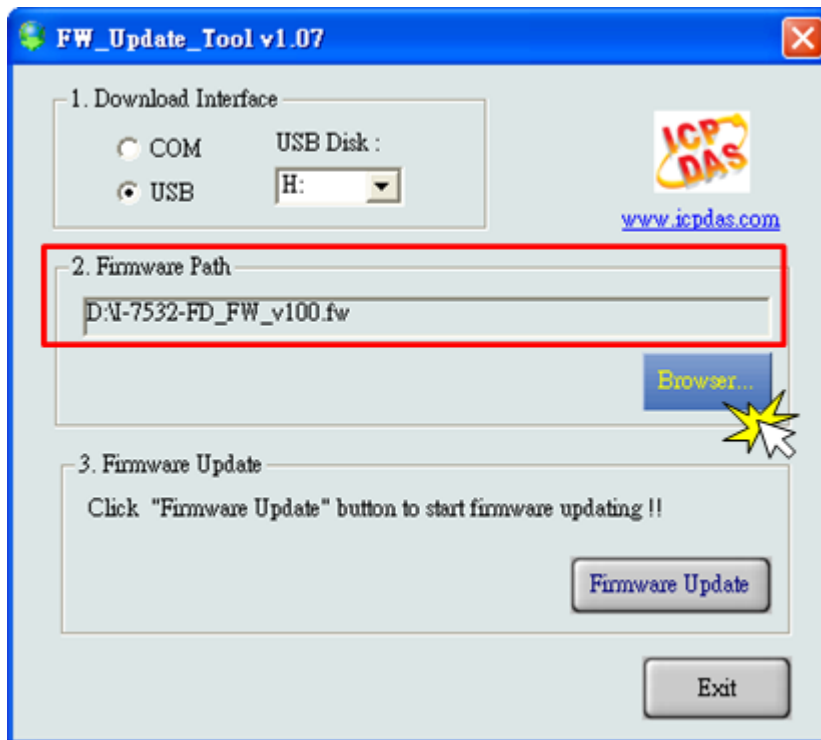

Step 8: Select USB port and the necessary USB Disk of PC

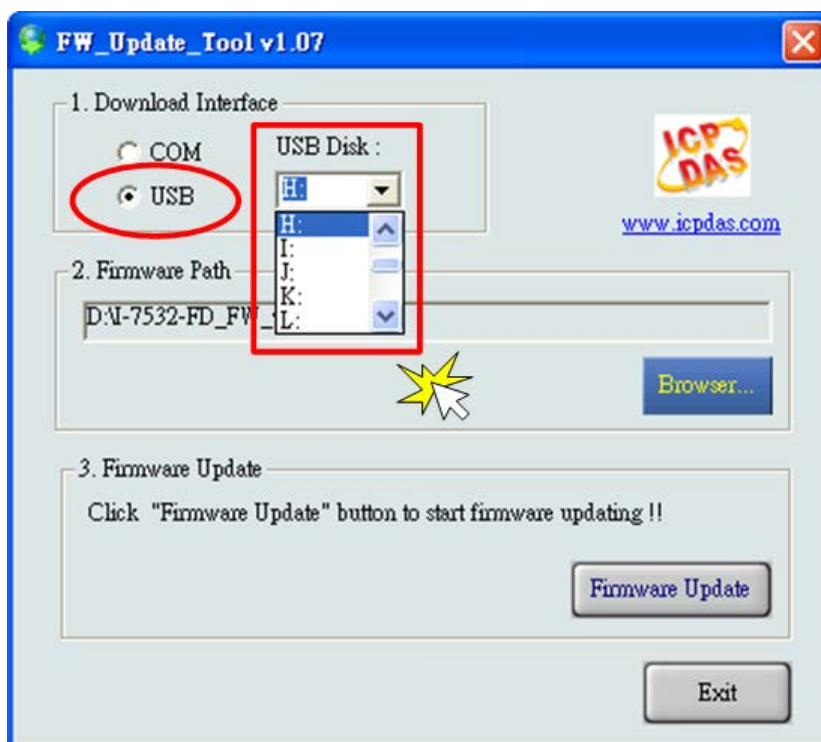

Step 9: Press the “Browser...” button and select the firmware file (*.fw).

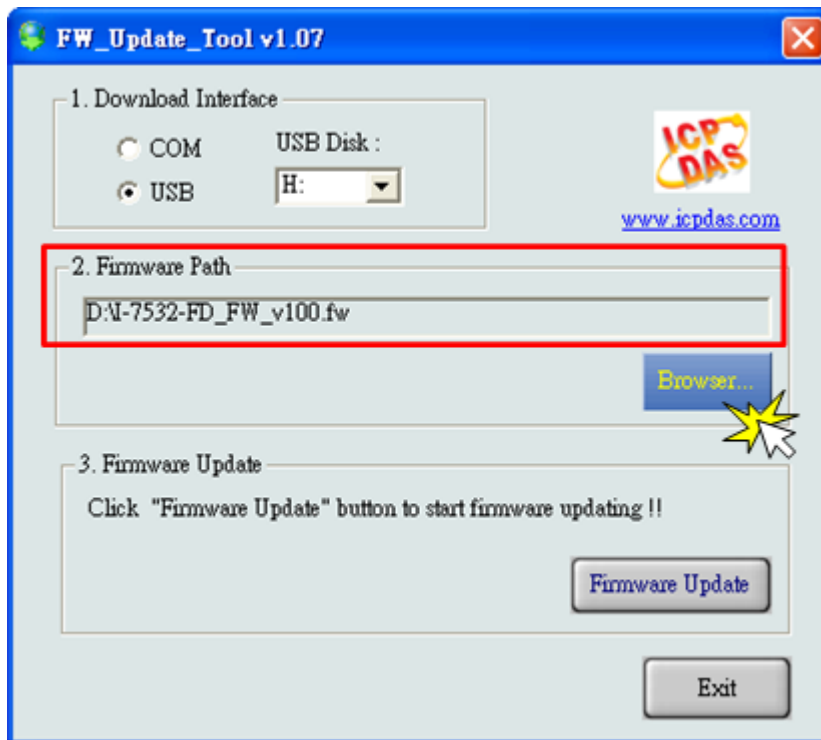

Step 10: Press the “Firmware Update” button to update the firmware. After successfully to update the firmware, the “Firmware Update Success! Please Reboot Module!” information will be display on the “3. Firmware Update” frame.

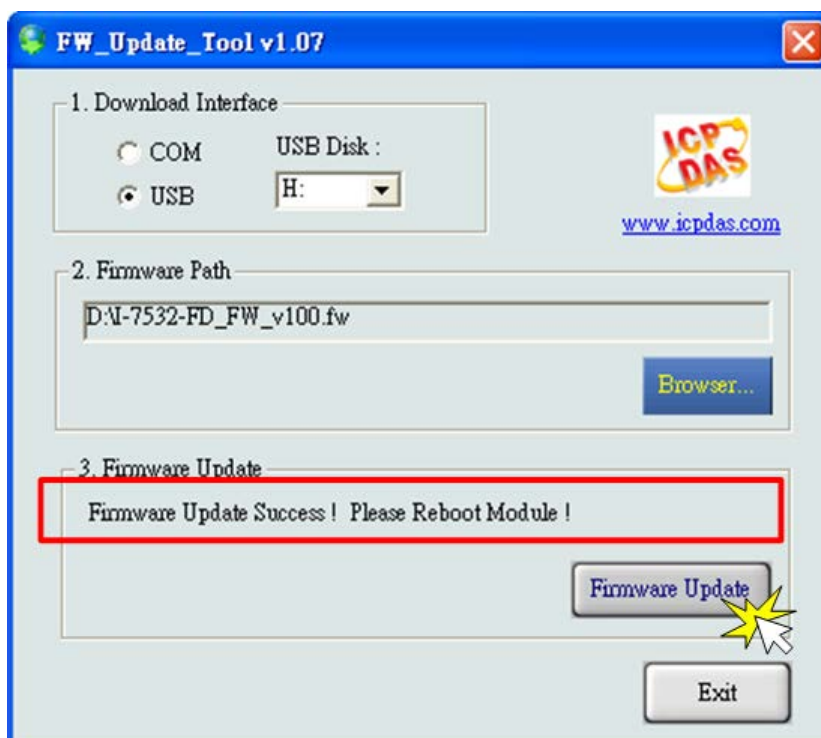

Step 11: Set the Init. dip switch to the “Off” position and reboot the module. Then press the “Exit” button to exit.

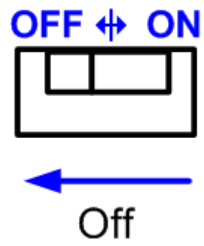

5. Appendix

5.1. Revision History

This chapter provides revision history information to this document. The table below shows the revision history.

Revision	Date	Description
1.0.0	2023/10/04	Initial issue

5.2. Dimension

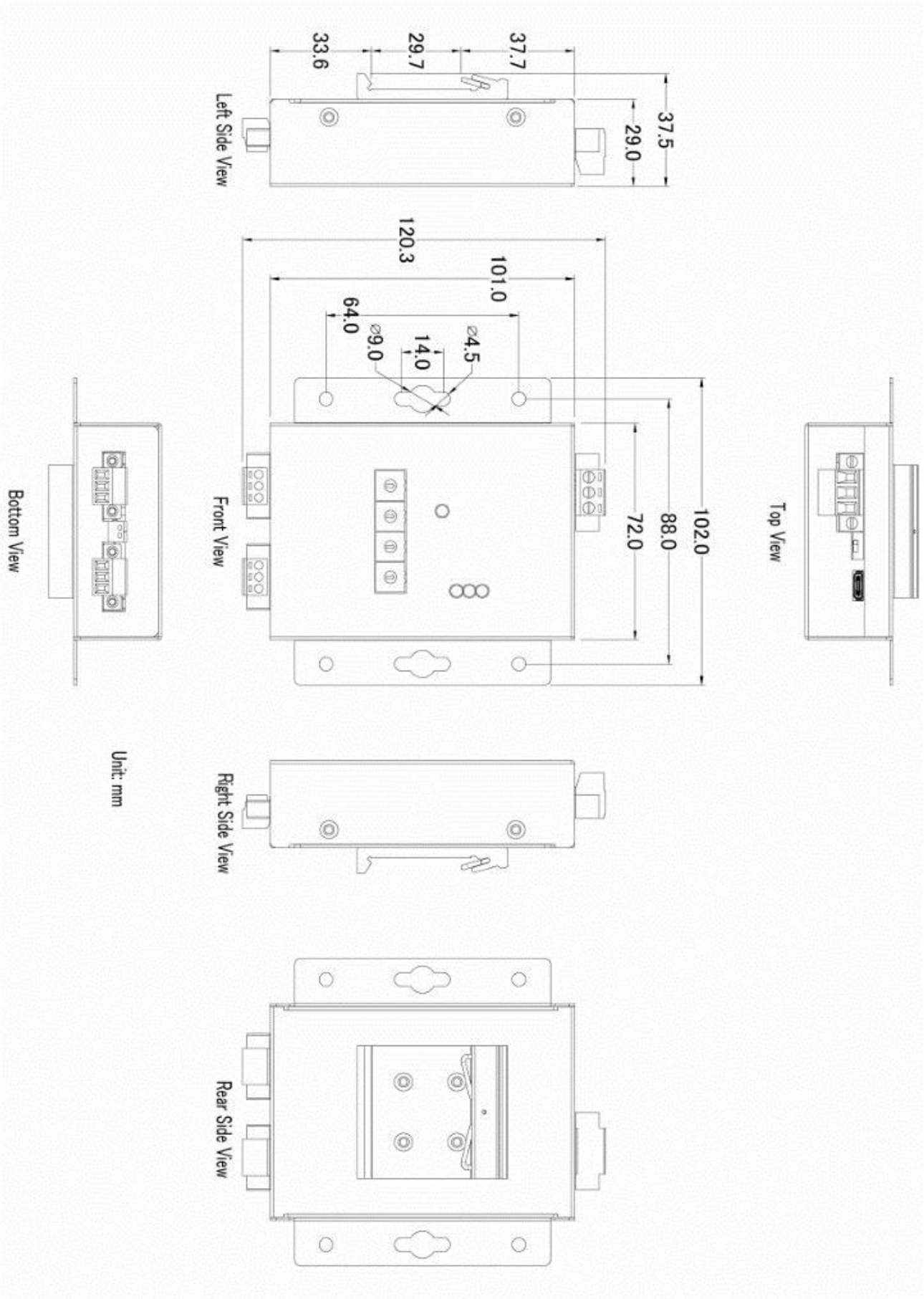

5.3. Valid Data Phase Bit Rate

Items	Supported Data Phase Bit Rate (kbps)				
	0	1	2	3	4
0	10000.000	8571.429	7500.000	6666.667	6000.000
5	5454.545	5000.000	4615.385	4285.714	4000.000
10	3750.000	3529.412	3333.333	3157.895	3000.000
15	2857.143	2727.273	2608.696	2500.000	2400.000
20	2307.692	2222.222	2142.857	2068.966	2000.000
25	1935.484	1875.000	1818.182	1764.706	1714.286
30	1666.667	1621.622	1578.947	1538.462	1500.000
35	1463.415	1428.571	1395.349	1363.636	1333.333
40	1304.348	1276.596	1250.000	1224.49	1200.000
45	1176.471	1153.846	1132.075	1111.111	1090.909
50	1071.429	1052.632	1034.483	1016.949	1000.000
55	983.6066	967.7419	952.381	937.500	923.0769
60	909.0909	895.5224	882.3529	869.5652	857.1429
65	845.0704	833.3333	821.9178	810.8108	800.000
70	789.4737	779.2208	769.2308	759.4937	750.000
75	740.7407	731.7073	722.8916	714.2857	705.8824
80	697.6744	689.6552	681.8182	674.1573	666.6667
85	659.3407	652.1739	645.1613	638.2979	631.5789
90	625.000	618.5567	612.2449	606.0606	600.000
95	594.0594	588.2353	582.5243	576.9231	571.4286
100	566.0377	560.7477	555.5556	550.4587	545.4545
105	540.5405	535.7143	530.9735	526.3158	521.7391
110	517.2414	512.8205	508.4746	504.2017	500.000
115	495.8678	491.8033	487.8049	483.871	480.000
120	476.1905	472.4409	468.750	465.1163	461.5385
125	458.0153	454.5455	451.1278	447.7612	444.4444
130	441.1765	437.9562	434.7826	431.6547	428.5714
135	425.5319	422.5352	419.5804	416.6667	413.7931
140	410.9589	408.1633	405.4054	402.6846	400.000
145	397.351	394.7368	392.1569	389.6104	387.0968
150	384.6154	382.1656	379.7468	377.3585	375.000
155	372.6708	370.3704	368.0982	365.8537	363.6364
160	361.4458	359.2814	357.1429	355.0296	352.9412
165	350.8772	348.8372	346.8208	344.8276	342.8571

170	340.9091	338.9831	337.0787	335.1955	333.3333
175	331.4917	329.6703	327.8689	326.087	324.3243
180	322.5806	320.8556	319.1489	317.4603	315.7895
185	314.1361	312.500	310.8808	309.2784	307.6923
190	306.1224	304.5685	303.0303	301.5075	300.000
195	298.5075	297.0297	295.5665	294.1176	292.6829
200	291.2621	289.8551	288.4615	287.0813	285.7143
205	284.3602	283.0189	281.6901	280.3738	279.0698
210	277.7778	276.4977	275.2294	273.9726	272.7273
215	271.4932	270.2703	269.0583	267.8571	266.6667
220	265.4867	264.3172	263.1579	262.0087	260.8696
225	259.7403	258.6207	257.5107	256.4103	255.3191
230	254.2373	253.1646	252.1008	251.046	250.000
235	248.9627	247.9339	246.9136	245.9016	244.898
240	243.9024	242.915	241.9355	240.9639	240.000
245 ~ 290	...				
290	202.7027	202.0202	201.3423	200.6689	200.000
295 ~ 365	...				
365	161.7251	161.2903	160.8579	160.4278	160.000
370~390	...				
390	151.5152	151.1335	150.7538	150.3759	150.000
395~470	...				
470	126.0504	125.7862	125.523	125.261	125.000
475 ~ 490	...				
490	120.9677	120.7243	120.4819	120.2405	120.000
495 ~ 590	...				
590	100.6711	100.5025	100.3344	100.1669	100.000