DeviceNet Slave Device

CAN-2024D

User's Manual

Warranty

Without contrived damage, all products manufactured by ICP DAS are warranted in one year from the date of delivery to customers.

Warning

ICP DAS revises the manual at any time without notice. However, no responsibility is taken by ICP DAS unless infringement act imperils to patents of the third parties.

Copyright

Copyright © 2015 is reserved by ICP DAS.

Trademark

The brand name ICP DAS as a trademark is registered, and can be used by other authorized companies.

Contents

1	Introduction.....	3
1.1	Overview.....	3
1.2	Hardware Specifications	4
1.3	Features.....	5
1.4	Application	5
2	Hardware	6
2.1	Structure.....	6
2.2	Node ID & Baud Rate Rotary Switch	7
2.3	LED Description.....	8
2.4	PIN Assignment	10
2.5	Wire Connection	10
2.6	Internal I/O Structure	11
3	DeviceNet Profile Area	12
3.1	DeviceNet Statement of Compliance.....	12
3.2	Identity Object (Class ID: 0x01)	13
3.3	Connection Object (Class ID:0x05)	14
3.4	Assembly Object (Class ID: 0x04)	15
3.5	Application Object1 (Class ID: 0x64).....	18
3.6	Application Object2 (Class ID: 0x65).....	20
4	Application	21
	Appendix A: Dimension.....	23
	Appendix B: Type Code Definition	24

1 Introduction

1.1 Overview

DeviceNet is one kind of the network protocols based on the CAN bus and mainly used for the embedded network of the machine control, such as industrial machine control , aircraft engines monitoring, factory automation, medical equipments control, remote data acquisition, environmental monitoring, and packaging machines control, etc.

The CAN-2024D follows DeviceNet specification Volume I/II, Release 2.0. You can access the analog output status and set the configuration via DeviceNet EDS file. This module has 4-channel 14-bit voltage or current output. It can be applied to various applications. By the DeviceNet masters of ICP DAS, you can quickly build a DeviceNet network to approach your requirements.



1.2 Hardware Specifications

Analog Output:

- Output Channels: 4
- Output Type: 0~ 5 V, +/- 5 V, 0~ 10 V, +/- 10 V, 0 ~ 20 mA, 4 ~ 20 mA
- Resolution: 14-bit
- Accuracy: Voltage: +/- 0.1% FSR; Current: +/- 0.2% FSR
- Zero Drift: Voltage: +/-30 μ V/°C ; Current: +/-0.2 μ V/°C
- Span Drift: +/-20ppm/°C
- Voltage Output Capability: 10V@5mA
- Max Current Load Resistance: External +24 V : 1050 Ohms
- Power-on and Safe Value: Yes
- 4KV ESD Protection: Yes, Contact for each terminal.
- Intra-module Isolation, Field to Logic: 3000 V_{DC}

Others:

- DeviceNet Status: 3 LEDs for PWR / NET / MOD.
- Terminator Resister: 1 LED as terminator resister indicators
- AO LED: 8 LEDs as analog output indicators.
- Power Supply: Unregulated +10 ~ +30 V_{DC}.
- Power Consumption: 1.5 W.
- Operating Temperature: -25 ~ 75 °C.
- Storage Temperature: -30 ~ 80 °C.
- Humidity: 10 to 90% RH, Non-condensing.
- Dimensions: 32.3 mm x 99 mm x 77.5 mm (W x L x H) [Detail](#).

1.3 Features

- DeviceNet general I/O slave devices.
- Comply with DeviceNet specification Volume I, Release 2.0 & Volume II, Release 2.0, Errata 5
- Group 2 Only Server (non UCMM-capable)
- Support Predefined Master/Slave Connection Set
- Connection supported:
 - 1 connection for Explicit Messaging
 - 1 connection for Polled I/O
 - 1 connection for Bit-Strobe I/O connection
- Support DeviceNet heartbeat and shutdown messages
- Provide EDS file for standard DeviceNet master interface.
- NET, MOD and PWR Led indicators

1.4 Application

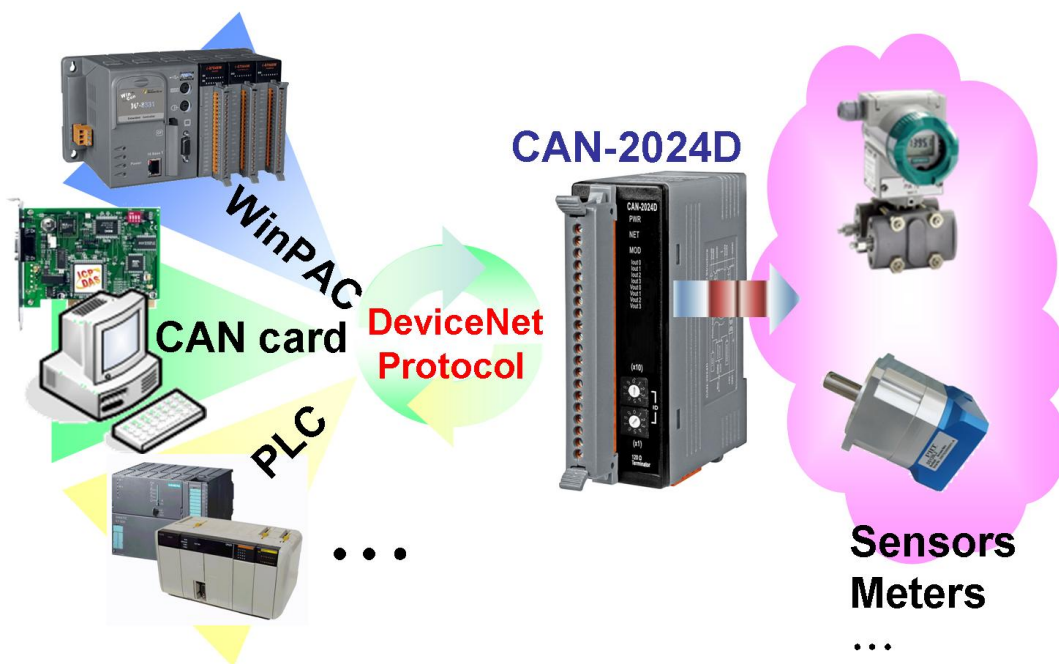

2 Hardware

2.1 Structure

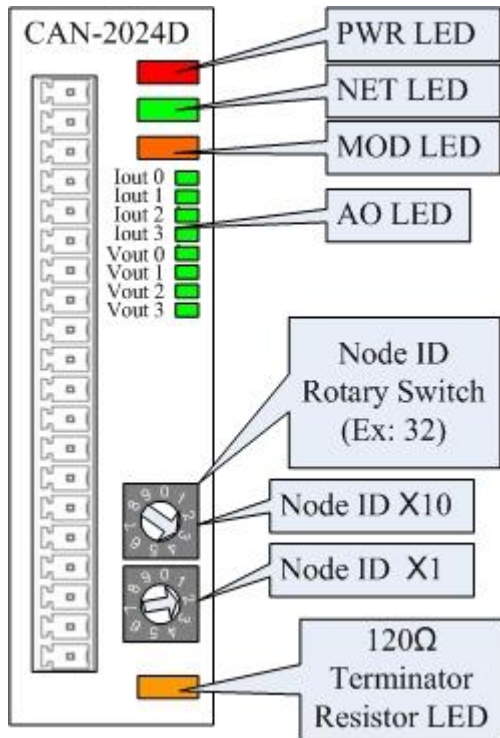

(Top View)

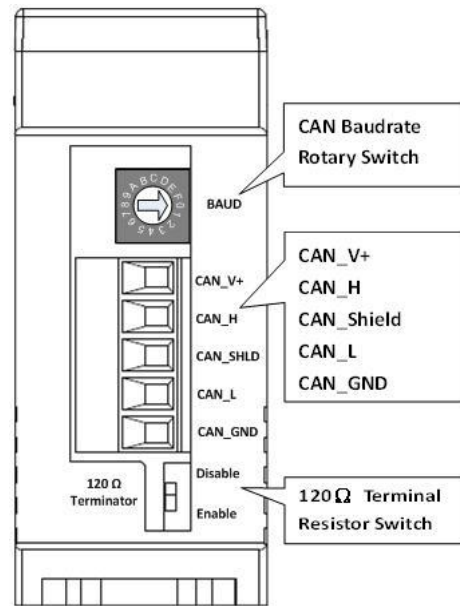

(Bottom View)

2.2 Node ID & Baud Rate Rotary Switch

The rotary switches of node ID configure the node ID of CAN-2024D module. These two switches are numbers in base ten for the node ID. The node ID value of the following picture is 32.

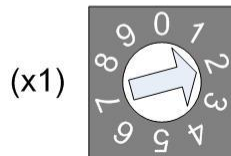
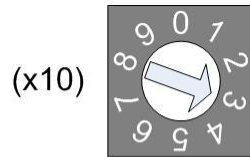

Node ID rotary switch

The rotary switch about baud rate configuration handles the CAN baud rate of CAN-2024D module. The relationship between the rotary switch value and the practical baud rate is presented in the following table.

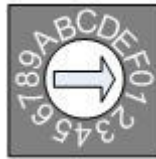

Baud rate rotary switch

Rotary Switch Value	Baud rate (kbps)
0	125
1	250
2	500

2.3 LED Description

PWR LED

The CAN-2024D needs the power of 10 ~ 30 V_{DC}. Under a normal connection, a good power supply and a correct voltage selection, as the unit is turned on, the LED will light up in red.

NET LED

The NET LED indicates the current status of the DeviceNet communication link.

Condition	status	Indicates
Init Off	Off line	Device is not online
Off	Connection timeout	I/O connection timeout
Flashing	On line	Device is on line, but not communicating
Init solid	Link failed	(Critical) Device has detected an error that has rendered it incapable of communicating on the link; for example, detected a duplicate node address or network configuration error
Solid	On line, communicating	Device is online and communicating

MOD LED

This LED provides the devices status. It indicates whether or not the device is operating properly.

Condition	status	Indicates
Off	Normal	
Solid	Critical fault	Device has unrecoverable fault.
Flashing	Non_critical fault	Device has recoverable fault to recover. If users want to fix the problem, reconfiguring device's MAC ID or resetting device may work.

Terminal Resistor LED

When enable the 120Ω terminator resistor, the LED will be turned on.

Iout LED

If the Iout LED is turned on, it means that the current is outputting on corresponding output channel.

Vout LED

If the Vout LED is turned on, it means that the voltage is outputting on corresponding output channel.

2.4 PIN Assignment

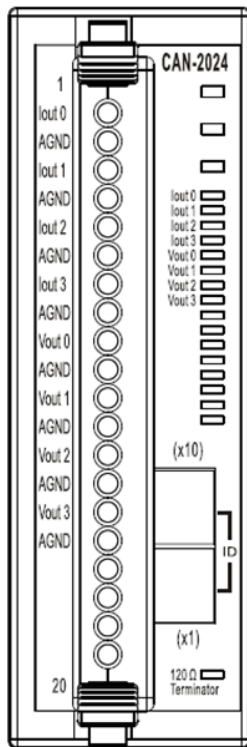

Terminal No.	Pin Assignment
01	Iout 0
02	AGND
03	Iout 1
04	AGND
05	Iout 2
06	AGND
07	Iout 3
08	AGND
09	Vout 0
10	AGND
11	Vout 1
12	AGND
13	Vout 2
14	AGND
15	Vout 3
16	AGND
17	N/A
18	N/A
19	N/A
20	N/A

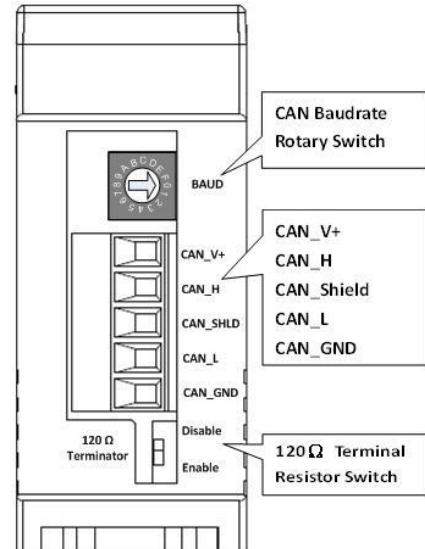

2.5 Wire Connection

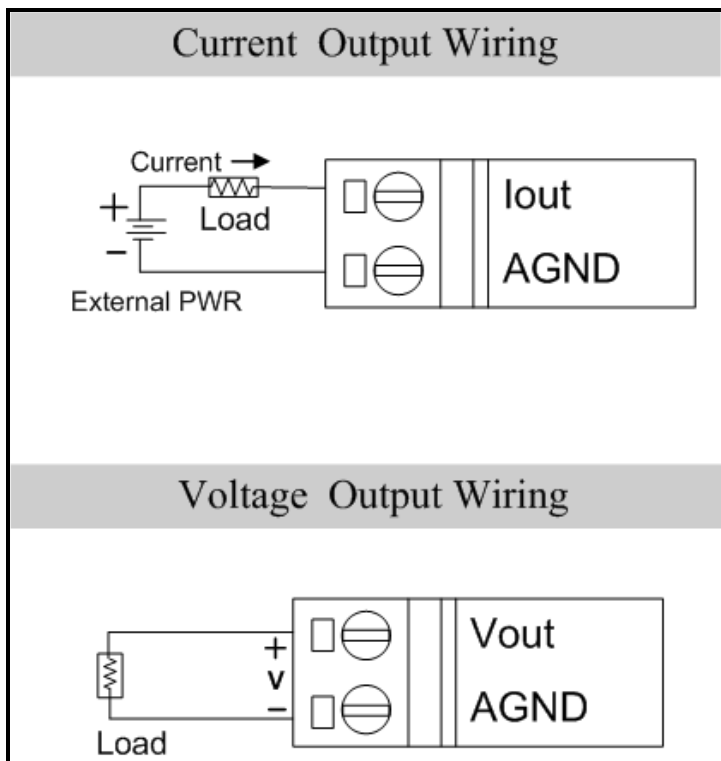

5-pin screw terminal block

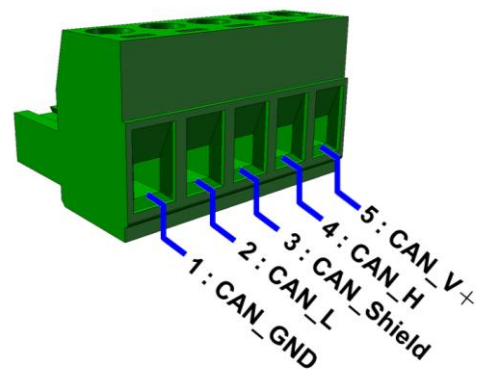

2.6 Internal I/O Structure

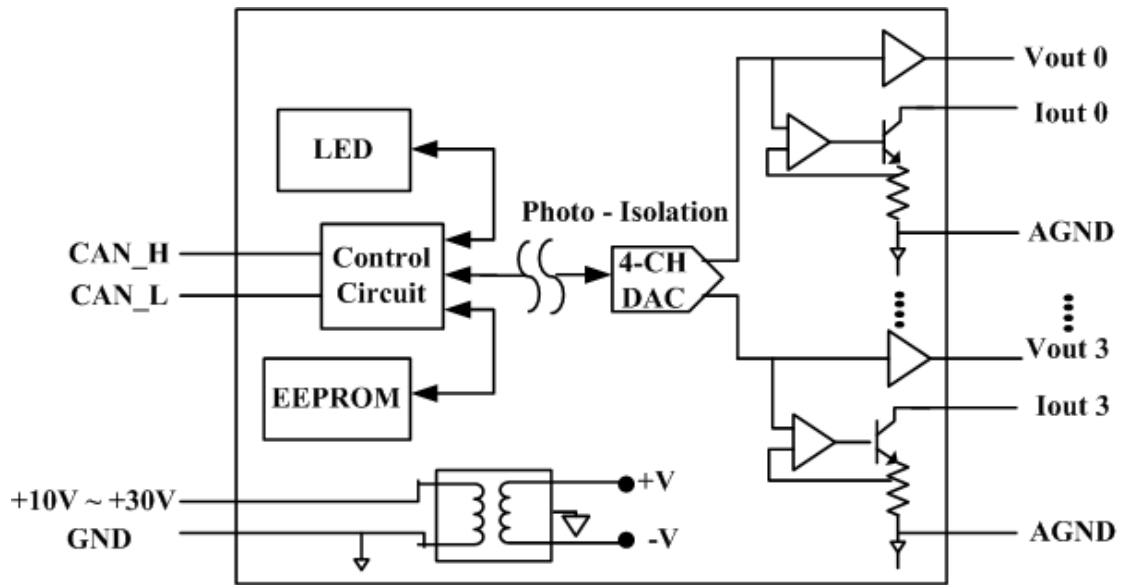

Internal I/O Structure

3 DeviceNet Profile Area

This section describes the detailed functions for each object class that is implemented in the CAN-2024D DeviceNet network.

3.1 DeviceNet Statement of Compliance

General Device Data

Device Information	Description
Version Description of DeviceNet Specification	Volume I, Release 2.0 & Volume II, Release 2.0
Vendor Name	ICP DAS
Device Profile Name	CAN-2024D
Production Revision	1.1

DeviceNet Physical Conformance Data

Item	Description
LED Support	Yes
MAC ID Setting	Switch (0 ~ 63)
Default MAC ID	1
Communication Baud Rate Setting	Switch (125, 250, 500 kbps)
Default Baud Rate	125 kbps
Predefined Master/Slave Connection Set	Group 2 Only Server

3.2 Identity Object (Class ID: 0x01)

This object provides the identification and general information about the device.

Class Attribute (Instance ID=0)

Attribute ID	Attribute name	Data Type	Method	Value
0x01	Revision	UINT	Get	0001
0x02	Max Instance	UINT	Get	1

Class Service

Service Code	Service name	Support
0x0E	Get_Attribute_Single	Yes

Instance Attribute (Instance ID=1)

Attribute ID	Description	Method	DeviceNet Data Type	Value
1	Vendor	Get	UINT	803
2	Product type	Get	UINT	0x00
3	Product code	Get	UINT	0x400
4	Major. Minor of firmware version	Get	Struct of USINT USINT	1.1
5	Status	Get	WORD	-
6	Serial number	Get	UDINT	1
7	Product name	Get	Short_String	CAN-2024D
10	Heartbeat Interval	Get/Set	USINT	0(default)

Instance Service

Service Code	Service name	Support
0x0E	Get_Attribute_Single	Yes
0x10	Set_Attribute_Single	Yes
0x05	Reset	Yes

Note: Use the Instance Service 0x05 will reboot the device.

3.3 Connection Object (Class ID:0x05)

This section presents the externally visible characteristics of the Connection Objects associated with the Predefined Master/Slave Connection Set within slave devices.

The default IO connection path is as follow.

Connection Path	Class ID	Instance ID	Attribute ID
Poll Produced	0x04	0x64	0x03
Poll Consumed	0x04	0x64	0x03
Bit Strobe Produced	0x04	0x64	0x03
Bit Strobe Consumed	0x04	0x64	0x03

Connection Instance ID	Description
1	References the Explicit Messaging Connection into the Server
2	References the Poll I/O Connection
3	References the Bit–Strobe I/O Connection

3.4 Assembly Object (Class ID: 0x04)

The Assembly Object binds attributes of multiple objects, which allows data to or from each object to be sent or received over a single connection. Assembly objects can be used to bind input data or output data. The terms of "input" and "output" are defined from the network's point of view. An input will produce data on the network and an output will consume data from the network.

Class attribute (Instance ID=0)

Attribute ID	Attribute name	Data Type	Method	Value
0x01	Revision	UINT	Get	1
0x02	Max Instance	UINT	Get	0x05

Class service

Service Code	Service name	Support
0x0E	Get_Attribute_Single	Yes

Instance ID

Instance ID	OUTPUT	INPUT
0x64	Output values of all AO channels	Get values of all AO channels
0x65	Type codes of all AO channel	Get type code of all AO channels
0x66	The mask of safe values of all AO channels	Get the mask of the safe values of all AO channels
0x67	The safe values of all AO channel	Get the safe values of all AO channels
0x68	Power on values of all AO channels	Get the power on values of all AO channels

Node: About the definition of the type codes, please refer to the appendix B for details.

Contents of Each Assembly Object Instance

Instance ID	Description	Type	Method	Default Value
0x64	Channel 0 ~ 3 AO output values	UINT ... UINT	Get/Set	0x0000 ... 0x0000
0x65	Channel 0 ~ 3 AO type codes	USINT ... USINT	Get/Set	0x33 ... 0x33
0x66	Channel 0 ~ 3 AO mask values of the safe values	USINT ... USINT	Get/Set	0x00 ... 0x00
0x67	Channel 0 ~ 3 AO safe values	UINT ... UINT	Get/Set	0x0000 ... 0x0000
0x68	Channel 0 ~ 3 AO power on values	UINT ... UINT	Get/Set	0x0000 ... 0x0000

Parameter description of Assembly Object Instance

Instance ID	Data Range	Parameter Description
0x64	Refer to Appendix B for the corresponding output values	Channel 0~3 output values
0x65	Refer to Appendix B for the type code definition	Channel 0~3 AO type codes
0x66	0x00 or 0x01	Channel 0~3 AO mask values of the safe values value=0x01 => apply the safe value setting value=0x00 => apply AO output value
0x67	Refer to Appendix B for the corresponding output values	Channel 0~3 AO safe values
0x68	Refer to Appendix B for the corresponding output values	Channel 0~3 AO power on values

Instance attribute (Instance ID=0x64~0x68)

Attribute ID	Description	Method	DeviceNet Data Type	Value
0x03	Data	Get/Set	OUTPUT/ INPUT	Dependent on instance ID

Instance service

Service Code	Service name	Support
0x0E	Get_Attribute_Single	Yes
0x10	Set_Attribute_Single	Yes

3.5 Application Object1 (Class ID: 0x64)

Application objects are the interfaces between an application and the DeviceNet Layer. The attributes of application Objects contain the data for the application, which are accessed and exchanged via DeviceNet. DeviceNet accesses application data by invoking read and write functions. These functions need to be provided by an Application Object. DeviceNet provides `Get_Attribute_Single` and `Set_Attribute_Single` to read and write the single AO channel configuration of the CAN-2024D module.

Class attribute (Instance ID=0)

Attribute ID	Attribute name	Data Type	Method	Value
0x01	Revision	UINT	Get	1
0x02	Max Instance	UINT	Get	0x04

Class service

Service Code	Service name	Support
0x0E	<code>Get_Attribute_Single</code>	Yes

Instance ID

Instance ID	Description
0x01	For accessing channel 0 AO configuration
0x02	For accessing channel 1 AO configuration
0x03	For accessing channel 2 AO configuration
0x04	For accessing channel 3 AO configuration

Instance attribute (Instance ID=0x01~0x04)

Attribute ID	Description	Method	Data Type	Default Value
0x01	AO value	Get/Set	UINT	0x0000
0x02	AO type code	Get/Set	USINT	0x33
0x03	AO mask value for safe value	Get/Set	USINT	0x00
0x04	AO safe value	Get/Set	UINT	0x0000
0x05	AO power on value	Get/Set	UINT	0x0000

Parameter description of Application Object1 attributes

Attribute ID	Data Range	Parameter Description
0x01	Refer to Appendix B for the corresponding output values	Channelx AO output value
0x02	Refer to Appendix B for the corresponding output values	Channelx AO type code
0x03	0x00 or 0x01	Channelx AO mask value for the safe value value=0x01 => apply safe value setting value=0x00 => apply AO output value
0x04	Refer to Appendix B for the corresponding output values	Channelx AO safe value
0x05	Refer to Appendix B for the corresponding output values	Channelx AO power on value

Note: Channelx is channel number of module, which is selected by Instance ID

Instance service

Service Code	Service name	Support
0x0E	Get_Attribute_Single	Yes
0x10	Set_Attribute_Single	Yes

3.6 Application Object2 (Class ID: 0x65)

Application Object2 defines parameters for saving configurations into EEPROM or loading factory default setting.

Class attribute (Instance ID=0)

Attribute ID	Attribute name	Data Type	Method	Value
0x01	Revision	UINT	Get	1
0x02	Max Instance	UINT	Get	0x01

Class service

Service Code	Service name	Support
0x0E	Get_Attribute_Single	Yes

Instance attribute (Instance ID=1)

Attribute ID	Description	Method	Data Type	Default Value
0x01	Save all configurations into EEPROM or using factory default configuration setting	Set	USINT	-

Parameter description of Application Object2 attributes

Attribute ID	Data Range	Parameter Description
0x01	0x01: Use default configuration 0x02: Save all configurations to EEPROM	0x01: After restarting the device, all configurations will become default setting. 0x02: Save all channels configuration into EEPROM

Instance service

Service Code	Service name	Support
0x10	Set_Attribute_Single	Yes

4 Application

Application Object1 (Class ID:0x64) lists all the parameters of the module. Each Instance ID is corresponding to the different channel. By using “Set/Get Attribute Single” service, you can read/write the parameters of each channel.

Example1:

Set channel0 AO output value.

(Class ID: **0x64**, Instance ID: **0x01**, Attribute ID **0x01**).

If the node ID of the CAN-2024D is 1, and the master (ID: 0x0A) has completed “Explicit” connection with the device. The default type code of all channels are 0x33 (-10V ~ +10V). By setting the value of Attribute ID 0x01 to 0x7FFF, you can set the channel0 AO output data to +10V_{DC}.

IDENTIFIER BITS											RTR	Data Length	8-byte Data (byte) (HEX)							
Destination MAC ID													0	1	2	3	4	5	6	7
10	9	8	7	6	5	4	3	2	1	0										
1	0	0	0	0	0	0	1	1	0	0	0	6	0A	10	64	01	01	FF	7F	--

Master → **Slave (CAN-2024D)**

IDENTIFIER BITS											RTR	Data Length	8-byte Data (byte) (HEX)							
Source MAC ID													0	1	2	3	4	5	6	7
10	9	8	7	6	5	4	3	2	1	0										
1	0	0	0	0	0	0	1	0	1	1	0	2	0A	90	--	--	--	--	--	--

Master ← **Slave (CAN-2024D)**

Set the value 0x7FFF to the Application Object1 with Instance ID 0x01 and Attribute ID 0x01. After sending the “Set Attribute Single”, the slave device will response 0x90 to mean that the setting is OK. Then the Vout0 will output +10V_{DC} and the Vout0 LED will turn on.

Via changing the Attribute ID of the Application Object, you can set other parameters of this device.

Example2:

Get channel1 AO type code data

(Class ID: **0x64**, Instance ID: **0x02**, Attribute ID **0x02**).

If the node ID of the CAN-2024D is 1, and the master (ID: 0x0A) has completed “Explicit” connection with the device. By getting the value of the object with attribute ID 0x02, you can get the channel 1 of the AO type code.

IDENTIFIER BITS											RTR	Data Length	8-byte Data (byte) (HEX)							
Destination MAC ID													0	1	2	3	4	5	6	7
10	9	8	7	6	5	4	3	2	1	0										
1	0	0	0	0	0	0	1	1	0	0	0	5	0A	0E	64	02	02	--	--	--

Master  **Slave (CAN-2024D)**

IDENTIFIER BITS											RTR	Data Length	8-byte Data (byte) (HEX)							
Source MAC ID													0	1	2	3	4	5	6	7
10	9	8	7	6	5	4	3	2	1	0										
1	0	0	0	0	0	0	1	0	1	1	0	3	0A	8E	33	--	--	--	--	--

Master  **Slave (CAN-2024D)**

Get the value of Application Object1 with Instance ID 0x02 and Attribute ID 0x02. After sending the “Get Attribute Single”, the slave device responds the AO type code (0x33) at byte 2. The value 0x33 means that the channel1 is using -10V ~ +10V output range. About the type code, refer to the appendix B for the type code definition.

By changing the Instance ID and Attribute ID of the Application Object, you can get and set other channel parameters of this device.

Attribute 0x03 and 0x04 of Application Object1 are used for safe value configuration when “Explicit Message Timeout” error occurs. When setting the Attribute ID 0x03 to “0x1”, the safe value of this channel will be activated. If the Instance ID is set to 0x1, it means that the safe value of the channel 0 is active. Afterwards, you can configure the output safe value of this channel by setting the value of Attribute ID 0x04. When setting the Attribute ID 0x02 to “0x33”, Attribute ID 0x03 to “0x1” and Attribute ID 0x04 to “0x7FFF”, the Vout0 (channel 0) will output +10V_{DC} while the error occurs.

The Attribute 0x05 of Application Object1 can control the AO power on value of each channel. After setting this attribute, this AO channel will output AO power on value while booting up.

Appendix A: Dimension

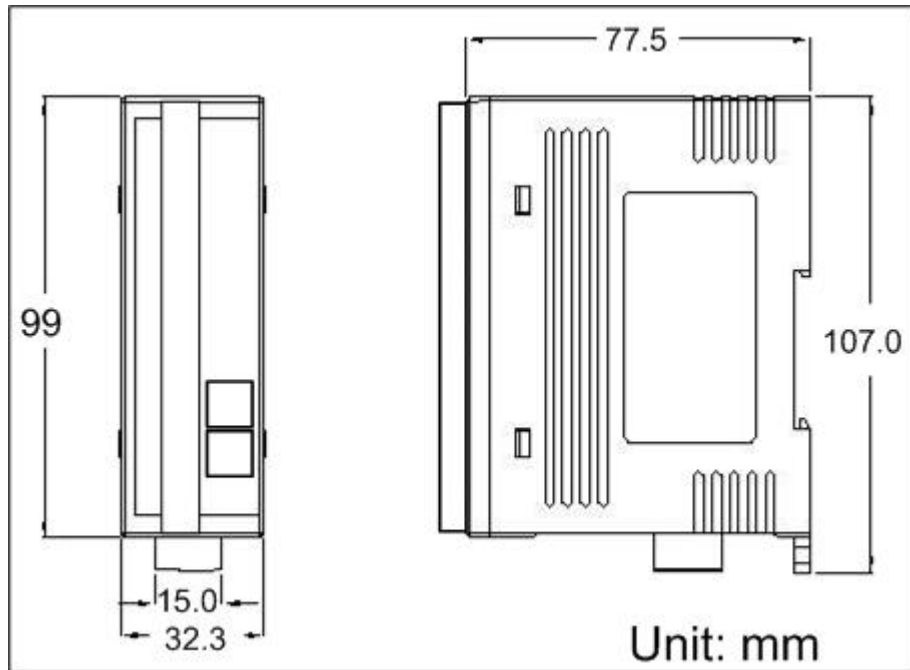

Appendix B: Type Code Definition

Type Code	Output Type	Output Range	Output Data (Hex)
0x30	Current	0 ~ 20 mA	0x0000 ~ 0x7FFF
0x31	Current	4 ~ 20 mA	0x0000 ~ 0x7FFF
0x32	Voltage	0 ~ 10 V _{DC}	0x0000 ~ 0x7FFF
0x33 (default)	Voltage	-10 ~ +10 V _{DC}	0x8000 ~ 0x7FFF
0x34	Voltage	0 ~ 5 V _{DC}	0x0000 ~ 0x7FFF
0x35	Voltage	-5 ~ +5 V _{DC}	0x8000 ~ 0x7FFF

Note: Different type code can be used for each AO channel.