

# SL-P6R1-WF/SL-PA6R1-WF User Manual

Stack Light Monitoring Modules → Ver. 2.0, Sep. 2018



## WARRANTY

All products manufactured by ICP DAS are warranted against defective materials for a period of one year from the date of delivery to the original purchaser.

## WARNING

ICP DAS assumes no liability for damages consequent to the use of this product. ICP DAS reserves the right to change this manual at any time without notice. The information furnished by ICP DAS is believed to be accurate and reliable. However, no responsibility is assumed by ICP DAS for its use, nor for any infringements of patents or other rights of third parties resulting from its use.

## COPYRIGHT

Copyright © 2018 by ICP DAS. All rights are reserved.

## TRADEMARK

Names are used for identification only and may be registered trademarks of their respective companies.

## CONTACT Us

If you have any questions, please feel free to contact us via email at:

[service@icpdas.com](mailto:service@icpdas.com)

Written by Wayne Chen

## SUPPORT

This manual relates to the following modules:

SL-P6R1-WF

SL-PA6R1-WF

# TABLE OF CONTENTS

- 1. INTRODUCTION ..... 5**
  - 1.1 PRODUCT INFORMATION..... 7
    - 1.1.1 *Stack Light Monitoring IO Module Series* ..... 7
    - 1.1.2 *Selection Guide*..... 7
  - 1.2 FEATURES ..... 9
- 2. HARDWARE INFORMATION .....11**
  - 2.1 FRONT AND BACK PANEL..... 11
  - 2.2 SPECIFICATIONS..... 16
    - 2.2.1 *System Specifications* ..... 16
    - 2.2.2 *I/O Specifications*..... 17
  - 2.3 PIN ASSIGNMENTS..... 18
    - 2.3.1 *SL-P6R1-WF/SL-PA6R1-WF* ..... 18
  - 2.4 WIRING CONNECTIONS..... 20
  - 2.5 DIMENSIONS ..... 22
- 3. GETTING STARTED .....23**
  - 3.1 MOUNTING THE MODULE..... 23
  - 3.2 CONFIGURING THE BOOT MODE ..... 25
  - 3.3 CONNECTING TO WI-FI, A PC AND A POWER SUPPLY..... 26
  - 3.4 CONNECTING TO A NETWORK, A PC AND A POWER SUPPLY ..... 28
  - 3.5 CONNECTING TO RS-485, A PC AND A POWER SUPPLY..... 29
  - 3.6 USING THE ESEARCH UTILITY TO ASSIGN A NEW IP ..... 31
- 4. WI-FI CONFIGURATION .....33**
  - 4.1 INSTALL WiFi IIOT UTILITY..... 33
  - 4.2 SEARCH AND FIND THE MODULE ..... 33
  - 4.3 CONFIGURE AND TEST THE MODULE ..... 34
- 5. WEB CONFIGURATION .....39**
  - 5.1 HOME PAGE ..... 41
  - 5.2 NETWORK SETTINGS ..... 43
    - 5.2.1 *Network and Miscellaneous Settings* ..... 43
    - 5.2.2 *IP Address Configuration* ..... 44
    - 5.2.3 *General Configuration Settings* ..... 47
    - 5.2.4 *Restoring Factory Defaults* ..... 48
  - 5.3 WI-FI SETTINGS ..... 50
    - 5.3.1 *Wi-Fi Status*..... 50
    - 5.3.2 *Wi-Fi Settings*..... 51

- 5.4 I/O SETTINGS ..... 53
  - 5.4.1 DO Control..... 53
  - 5.4.2 DI/DO Configuration..... 54
- 5.5 STACK LIGHT..... 55
  - 5.5.1 Stack Light Settings ..... 55
  - 5.5.2 Combinatorial Table Settings ..... 56
- 5.6 MQTT .....57
  - 5.6.1 Connectivity Settings..... 57
  - 5.6.2 Last Will Settings..... 59
  - 5.6.3 Publication Settings..... 60
  - 5.6.4 Subscription Settings..... 62
- 5.7 FILTER ..... 63
  - 5.7.1 Filter Settings ..... 63
- 5.8 MONITOR ..... 64
- 5.9 CHANGE PASSWORD ..... 64
- 5.10 LOGOUT ..... 65
- 6. RS-485 INTERFACE .....66**
  - 6.1 INSTALL DCON UTILITY PRO ..... 66
  - 6.2 SEARCH AND FIND THE MODULE ..... 67
  - 6.3 CONFIGURE AND TEST THE MODULE ..... 69
- 7. MODBUS INFORMATION .....73**
  - 7.1 WHAT IS MODBUS RTU AND MODBUS TCP/IP? .....74
  - 7.2 MODBUS MESSAGE STRUCTURE.....74
    - 7.2.1 01 (0x01) Read the Status of the Coils (Read back DOs)..... 78
    - 7.2.2 02 (0x02) Read the Status of the Input (Read DIs)..... 80
    - 7.2.3 03 (0x03) Read the Holding Registers (Read back AOs)..... 82
    - 7.2.4 04 (0x04) Read the Input Registers (Read AIs)..... 84
    - 7.2.5 05 (0x05) Force a Single Coil (Write DO) ..... 86
    - 7.2.6 06 (0x06) Preset a Single Register (Write AO) ..... 88
    - 7.2.7 15 (0x0F) Force Multiple Coils (Write DOs)..... 90
    - 7.2.8 16 (0x10) Preset Multiple Registers (Write AOs) ..... 92
  - 7.3 MODBUS REGISTER TABLE..... 94
    - 7.3.1 Common Functions..... 94
    - 7.3.2 Specific Functions ..... 98
- 8. RELATED TOOLS .....104**
  - 8.1 LABVIEW..... 104
  - 8.2 OPC SERVER ..... 104
  - 8.3 SCADA..... 105
- APPENDIX: FAQ.....107**
  - A. HOW DO AVOID A BROWSER ACCESS ERROR THAT CAUSES A BLANK PAGE TO BE DISPLAYED WHEN USING INTERNET EXPLORER.....107

- B. HOW TO UPDATE THE FIRMWARE VIA ETHERNET?..... 109
- C. WHY IS THE HOST COMPUTER UNABLE TO PING OR SEARCH FOR THE SL SERIES MODULE? ..... 114
- D. WHAT IS DIGITAL-INPUT FILTER (DI FILTER)? ..... 115

# 1. Introduction

The main purpose of managing machine status is to reduce the amount of downtime and to reduce production costs. The easiest way to achieve this is by installing a SL-P6R1-WF/SL-PA6R1-WF intelligent module from ICPDAS, which monitors the output of the machine's indicators without affecting the operation of the equipment, thereby enabling the current operation stage of the machine to be mastered and ensuring timely command of the logistics system support in order to achieve production goals.

The SL-P6R1-WF/SL-PA6R1-WF is a stack light monitoring module with Wi-Fi, Ethernet and RS-485 interfaces. It includes 6-channel DC/AC digital input and 1-channel relay output that can be used to monitor the status of the stack light of the MES (Manufacturing Execution System) machine. The module can be used to detect the status of each color segment of the stack light as being either OFF, ON, or flashing. In addition to detecting the status of each individual color segment, the status of the combination of multiple color segments can also be defined, including the ability to report the duration of the previous status. With the popularity of 802.11 network infrastructure, the SL-P6R1-WF/SL-PA6R1-WF makes an easy way to incorporate wireless connectivity into monitoring and control systems. By integrating the SL-P6R1-WF/SL-PA6R1-WF module into your system, it is easy to implement stack light status monitoring on an MES via SCADA software to improve machine utilization and throughput.

# Stack Light Monitoring Solution

Easy to implement stack light status monitoring on an MES to improve machine utilization and throughput.



Status

Machine Utilization = RUN Time / ON Time

KPI = (RUN + LOST + TEST) Time / ON Time



iKAN series

#1.RUN #2.STOP

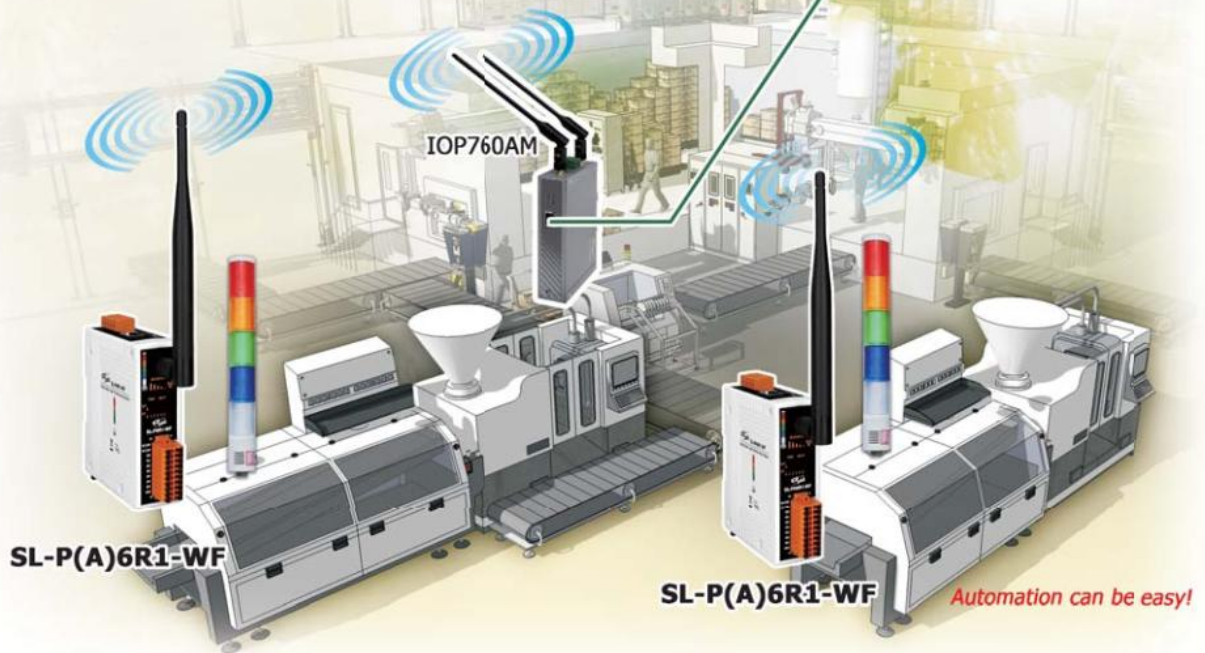

## 1.1 Product Information

### 1.1.1 Stack Light Monitoring IO Module Series

The SL series I/O modules support monitoring of DC and AC stack lights

The table below provides a description of each model.

Stack Light Monitoring	
SL-P6R1-WF	Single Stack Light Monitoring Module with Ethernet/RS-485 and Wi-Fi Interfaces and PoE for DC Stack Lights. (6 DC DI + 1 Relay) (RoHS)
SL-PA6R1-WF	Single Stack Light Monitoring Module with Ethernet/RS-485 and Wi-Fi Interfaces and PoE for AC Stack Lights. (6 AC DI + 1 Relay) (RoHS)

### 1.1.2 Selection Guide

Model	I/O Specifications			Wi-Fi IEEE 802.11 b/g	Ethernet 10/100 M	Modbus TCP	Modbus RTU
	D/I (Type)	D/O (Type)	Isolation				
SL-P6R1-WF	6-channel DC (Wet Contact)	1-channel (form A relay)	Yes	Yes	Yes	Yes	Yes
SL-PA6R1-WF	6-channel AC (Wet Contact)	1-channel (form A relay)					

### Industrial PoE Solutions

When using PoE devices such as the SL series, you can incorporate the ICP DAS **“PoE”** switch, the **“NS-205PSE”**, as the power source. The NS-205PSE automatically detects any connected devices, whether they are PoE devices or not. This mechanism ensures that the NS-205PSE will function simultaneously with both PoE and non-PoE devices.

Note that when acting as a power source for a PoE device, the NS-205PSE requires a power input ranging from +46 V<sub>DC</sub> to +55 V<sub>DC</sub>.





## 1.2 Features

### Built-in Web Server

Each SL series module contains a built-in web server that allows users to easily configure, monitor and control the module from a remote location using a web browser. **Please note that the web server is only available to the Ethernet interface.**

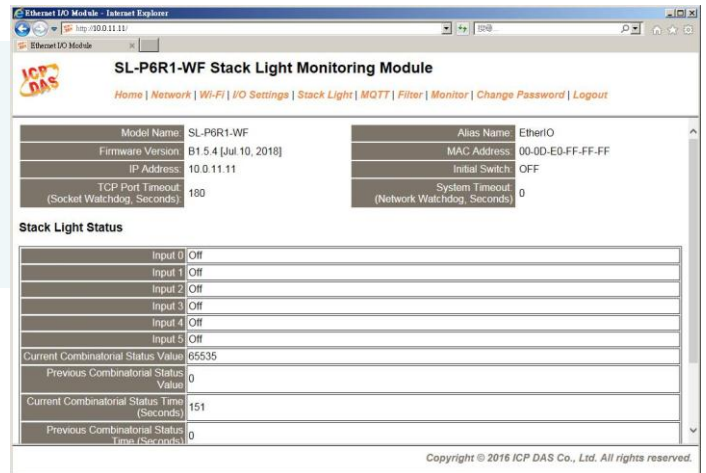

### Modbus Protocol

The Modbus TCP slave function on the Wi-Fi/Ethernet port and the Modbus RTU slave function on the RS-485 port can be used to provide data to remote SCADA software.

### All-in-one Module

A variety of I/O components are available on multiple channels in a single module, which provides the most cost effective I/O usage and enhances the performance of I/O operations.

### Automatic MDI/MDI-X Detection for Plug-and-Play

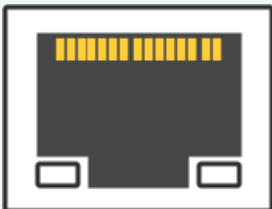

The RJ-45 port supports automatic sensing of MDI/MDI-x switching that can automatically detect the type of connection being used by the Ethernet device without requiring special straight or crossover cables.

## Built-in Dual Watchdog

The Dual Watchdog consists of a CPU Watchdog (for hardware functions) and a Host Watchdog (for software functions).

The **CPU Watchdog** will automatically reset it-self if the built-in firmware encounters an abnormal situation.

If there is no communication between the module and the host (PC or PLC) for a specified period of time (i.e., the Watchdog timeout), the **Host Watchdog** will set the digital output based on a predefined safe-value.



## Compatible with IEEE 802.11b/g standards

SL-P6R1-WF/SL-PA6R1-WF modules are complied with IEEE 802.11b/g standard from 2.4~2.5 GHz. It can be used to provide up to 11 Mbps for IEEE 802.11b and 54 Mbps for IEEE 802.11g to connect to your wireless LAN.

## 2. Hardware Information

### 2.1 Front and Back Panel

The following is a brief overview and description of the components included in SL series modules.

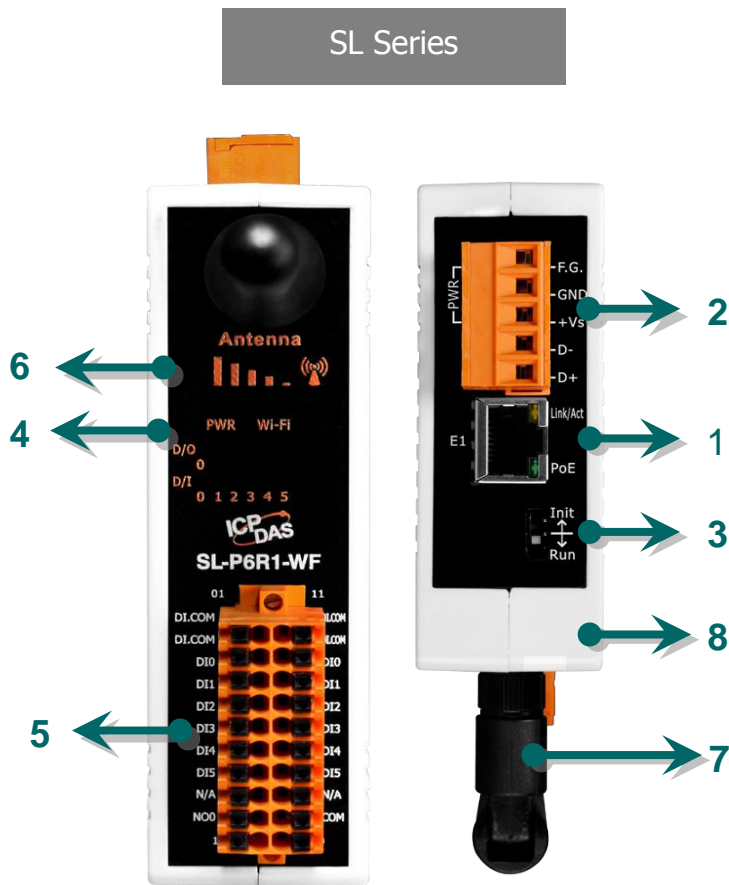

1	E1 Ethernet Port	5	J2 Terminal
2	J1 Terminal	6	Wi-Fi Signal Strength
3	Operating Mode Switch	7	Antenna
4	S1 System LED Indicator	8	Robust insulated and fire retardant case

## 1. Ethernet Port

The SL series module are equipped with an RJ-45 jack that is used as the 10/100 Base-TX Ethernet port and features networking capability. When an Ethernet link is detected and an Ethernet packet is received, the **PoE (Green)** indicator and the **Link/Act LED (Yellow)** indicator will be illuminated.

 **The Ethernet port supports PoE (Power-over-Ethernet) functions for SL series modules.**

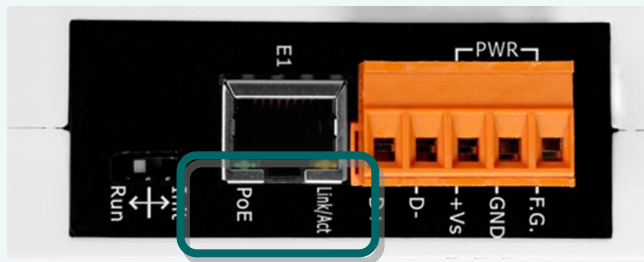

## 2. J1 Terminal

The J1 terminal is used to be connected to the power input and RS-485 bus.

### ■ DC Power Input:

The definition for “+Vs” and “GND” for use as the power supply applies to all types of SL series module.

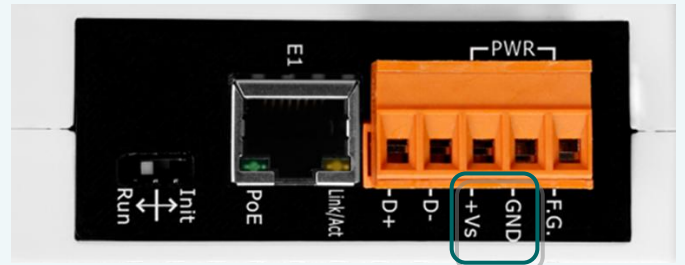

	Pin	Name	Function
<b>SL Series</b>	<b>1</b>	D+	RS-485 Port, Baud Rate = 1200 ~ 115200 bps
	<b>2</b>	D-	
	<b>3</b>	+Vs	+12 to +48 V <sub>DC</sub> Power Input
	<b>4</b>	GND	Ground Connection
	<b>5</b>	F.G.	Frame Ground

### 3. Operating Mode Switch

- **Init mode:** Uses factory settings and allows the firmware to be updated.
- **Run/Normal mode:** Uses customer settings.

 **Note: The module must be rebooted after changing operating mode.**

The operating mode switch for SL series modules is set to the **Run/Normal** position by default. When updating the SL firmware, the switch should be moved from the **Run/Normal** position to the **Init** position. The switch must then be returned to the **Run/Normal** position once the update is completed.

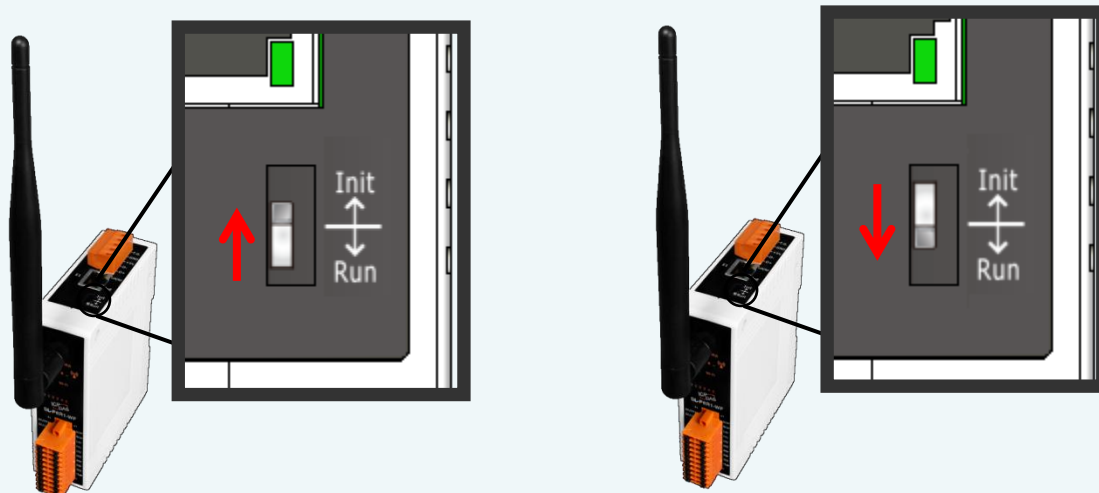

#### 4. System LED Indicator

Once power is supplied to the SL series module, the LED indicator will be illuminated as follows:

SL Series		
Name	Function	System LED Behavior
S1	Running Firmware	ON (Red)
E1	PoE	ON (Green)
	Link/Act	Flashing (Yellow)

#### 5. J2 Terminal

The J2 terminal depends on the type of the SL series module. For more detailed information regarding the pin assignments for the J2 terminal, refer to [Section 2.3. “Pin Assignments”](#).





#### 6. Wi-Fi Signal Strength

The Wi-Fi signal strength is indicated as shown below.

LED Status	Signal strength
	High
	Medium
	Low
	Bad or No Signal

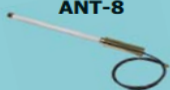
#### 7. Antenna

Following antennas are available to be used with the SL series modules.

External Antenna			
 <p><b>ANT-8</b></p>	<p>8 dBi 2.4GHz External Antenna (Omni-Directional)</p>	 <p><b>ANT-18</b></p>	<p>18 dBi 2.4GHz External Antenna (Directional)</p>
 <p><b>ANT-15</b></p>	<p>15 dBi 2.4GHz External Antenna (Omni-Directional)</p>	 <p><b>ANT-21</b></p>	<p>21 dBi 2.4GHz External Antenna (Directional)</p>
 <p><b>ANT-15YG-1</b></p>	<p>15 dBi 2.4GHz External Antenna (Directional)</p>		

## 2.2 Specifications

### 2.2.1 System Specifications

Modules	SL-P6R1-WF	SL-PA6R1-WF
<b>System</b>		
CPU	32-bit ARM MCU	
Dual Watchdog	Yes	
<b>Communication</b>		
RS-485 Port	Baud Rate = 1200 ~ 115200 bps	
Ethernet Port	10/100 Base-TX, 8-Pin RJ-45 x1, (Auto-negotiating, Auto-MDI/MDIX, LED Indicator) PoE (IEEE 802.3af, Class 1)	
<b>Wi-Fi Interface</b>		
Antenna	5 dBi (Omni-Directional)	
Standard Supported	IEEE 802.11 b/g	
Encryption	WEP, WPA and WPA2	
<b>LED Display</b>		
System Indicator	S1 (Red)	
PoE Indicator	E1 (Green)	
Link/Act Indicator	E1(Yellow )	
<b>Mechanical</b>		
Dimensions (W x L x H)	33 mm x 108 mm x 127 mm	
Installation	DIN-Rail mounting	
<b>Environment</b>		
Operating Temperature	-25 °C ~ +75 °C	
Storage Temperature	-30 °C ~ +80 °C	
Humidity	10 ~ 95 % RH, non-condensing	
<b>Power Requirements</b>		
Power Input	PoE: IEEE 802.3af, Class 1 Terminal Block: +12 ~ 48 V <sub>DC</sub> (non-regulated)	
Consumption	PoE	1.2 W Max.
	Non-PoE	1.0 W Max.



## 2.2.2 I/O Specifications

### 2.2.2.1 SL-P6R1-WF/SL-PA6R1-WF

Models	SL-P6R1-WF	SL-PA6R1-WF
<b>Digital Input</b>		
Input Channels	6	
Input Type (Device)	Wet Contact (Sink, Source)	
On Voltage Level	+10 V <sub>DC</sub> ~ +50 V <sub>DC</sub>	80 V <sub>AC</sub> ~ 240 V <sub>AC</sub>
Off Voltage Level	+4 V <sub>DC</sub> max.	30 V <sub>AC</sub> max.
Input Impedance	10 kΩ, 0.5W	150 kΩ, 2W
Programmable Digital Filter	0 to 6500 ms	NA
Max. Stack Light Flashing Speed	3 kHz	60 Hz
Able to detect the status of each color segment: ON, OFF, or Flashing	Yes	
Status monitoring for user-defined combinations of multiple color segments	Max. 81 combinations	
Report duration of previous status	Yes, 10 ~ 65500 ms	
Overvoltage Protection	+70 V <sub>DC</sub>	300 V <sub>AC</sub>
Isolation	3750 V <sub>DC</sub>	
<b>Digital Output</b>		
Output Channels	1	
Type	Power Relay, Form A (SPST N.O.)	
Operating Voltage Range	250 VAC or 30 VDC	
Max. Load Current	5 A	
Operate Time	6 ms	
Electrical Life (Resistive load)	VDE	5 A @ 250 VAC 30,000 ops (10 ops/minute) at 75°C
		5 A @ 30 VDC 70,000 ops (10 ops/minute) at 75°C
	UL	5 A @ 250 VAC/30 VDC 6,000 ops
		3 A @ 250 VAC/30 VDC 100,000 ops
Mechanical Life	20,000,000 ops at no load (300 ops/minute)	
Power-on Value	Yes, Programmable	
Safe Value	Yes, Programmable	

## 2.3 Pin Assignments

### 2.3.1 SL-P6R1-WF/SL-PA6R1-WF

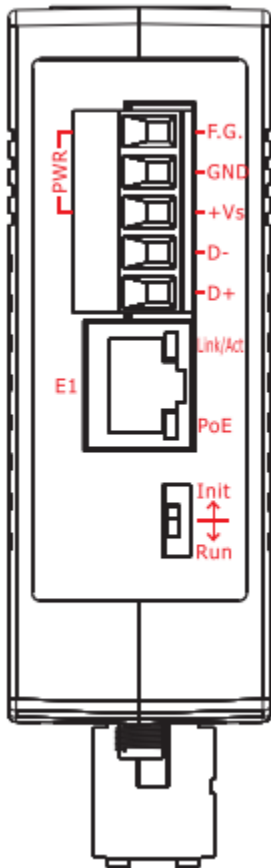

Terminal No.	Pin Assignment
PWR	F.G.
	GND
	+ Vs
RS-485	D-
	D+
E1	

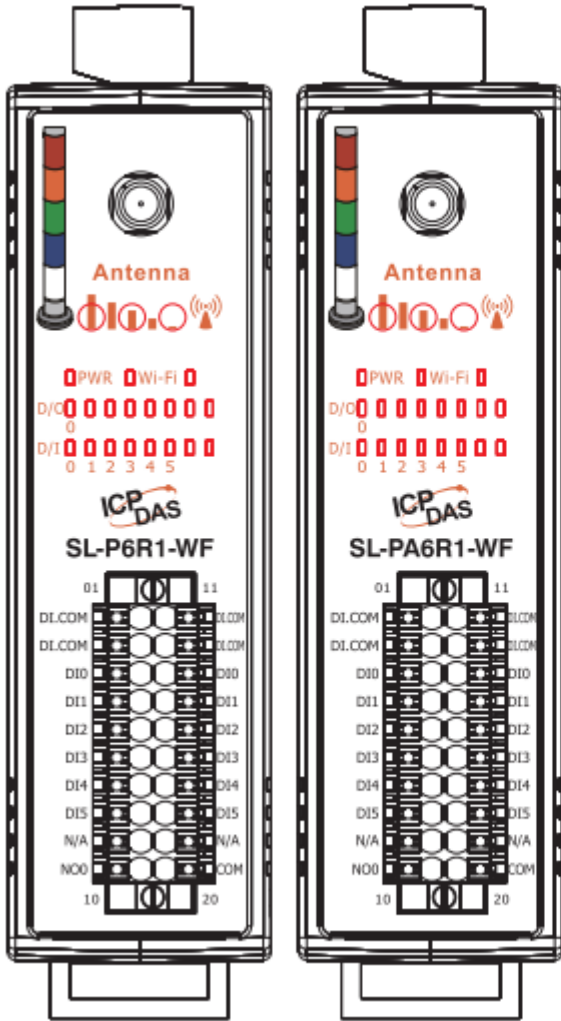

Pin Assignment	Terminal No.	Pin Assignment
DI.COM	01	11 DI.COM
DI.COM	02	12 DI.COM
DI0	03	13 DI0
DI1	04	14 DI1
DI2	05	15 DI2
DI3	06	16 DI3
DI4	07	17 DI4
DI5	08	18 DI5
N/A	09	19 N/A
NO0	10	20 COM

## 2.4 Wiring Connections

### ■ SL-P6R1-WF

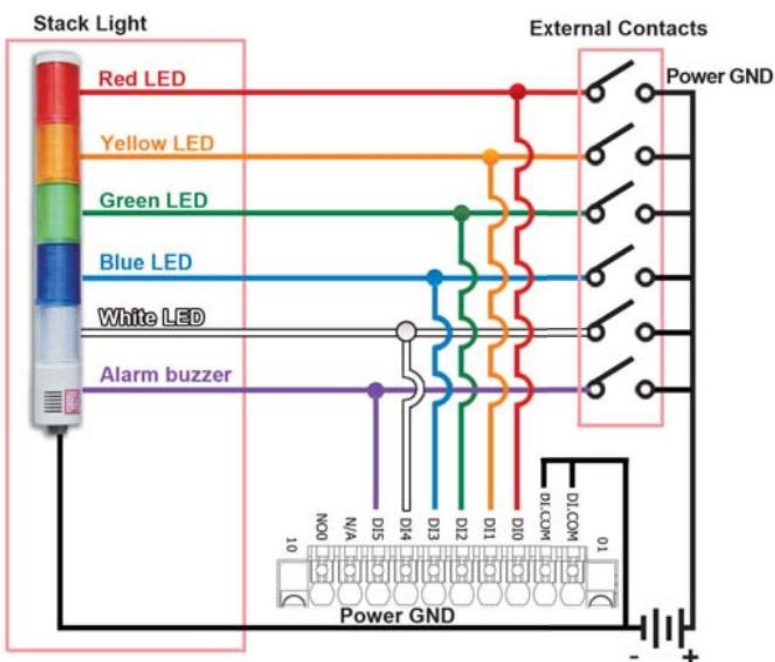
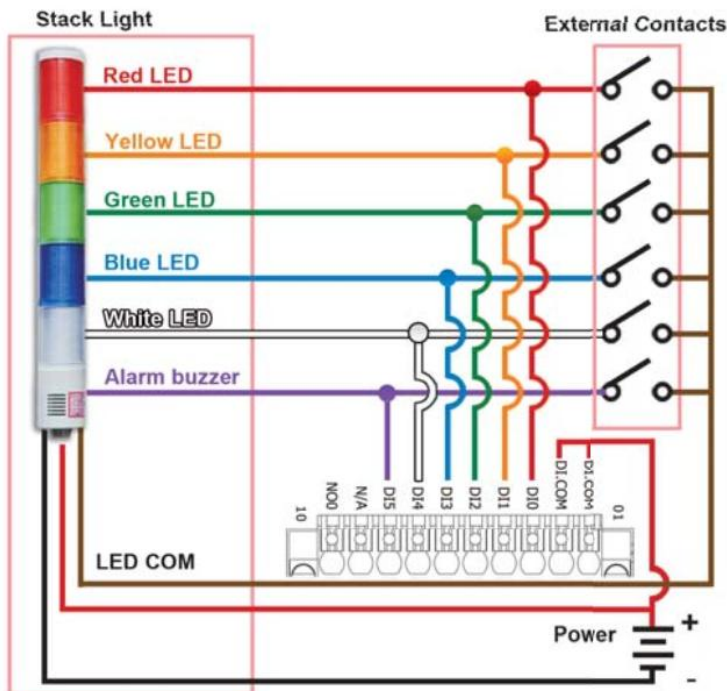

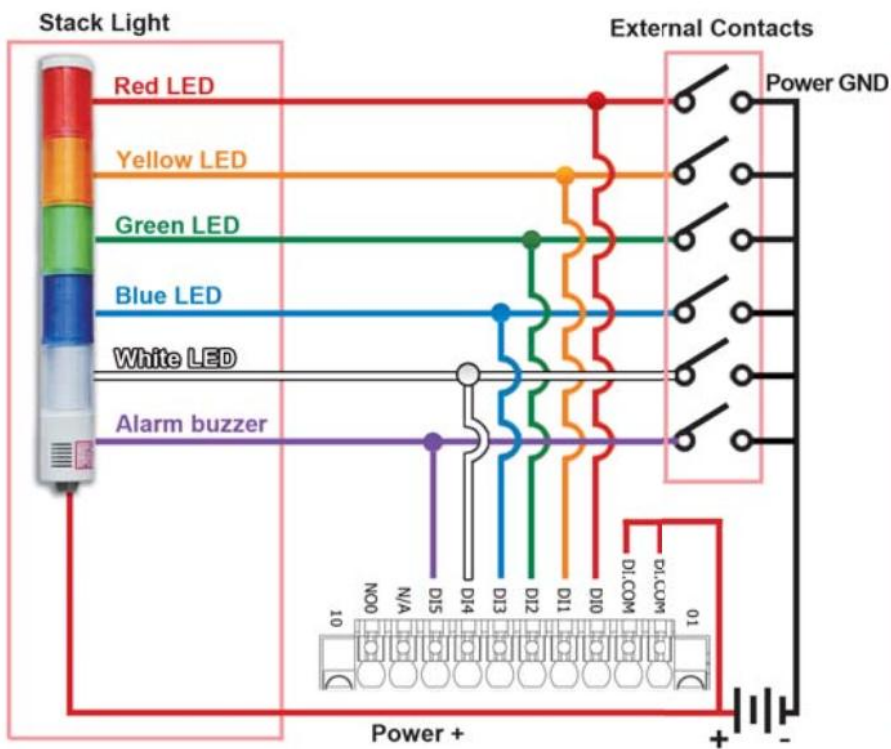

■ SL-PA6R1-WF

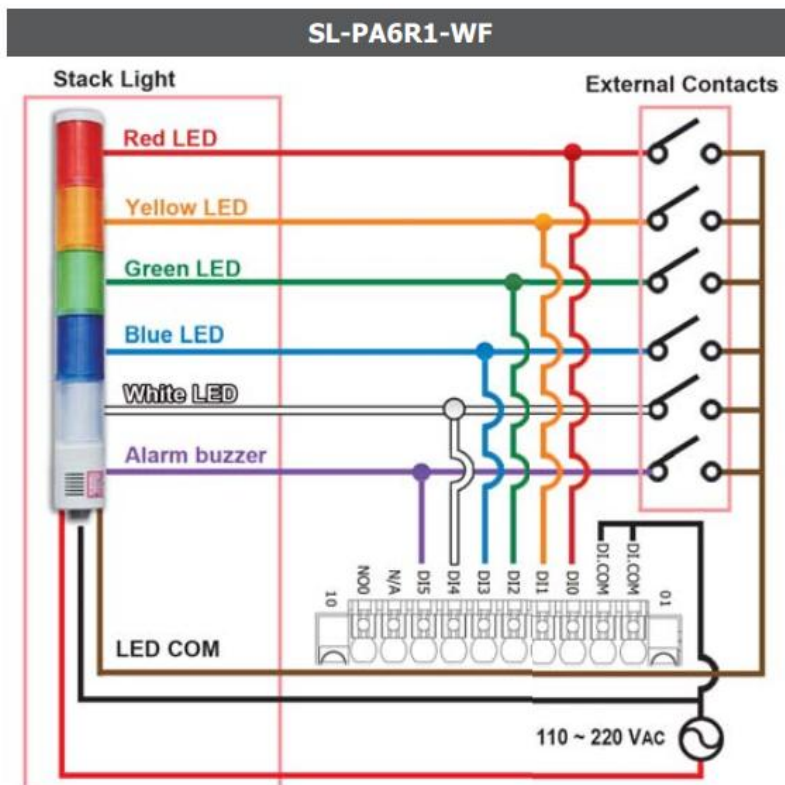

## 2.5 Dimensions

- The SL series dimensions are shown below in millimeters.

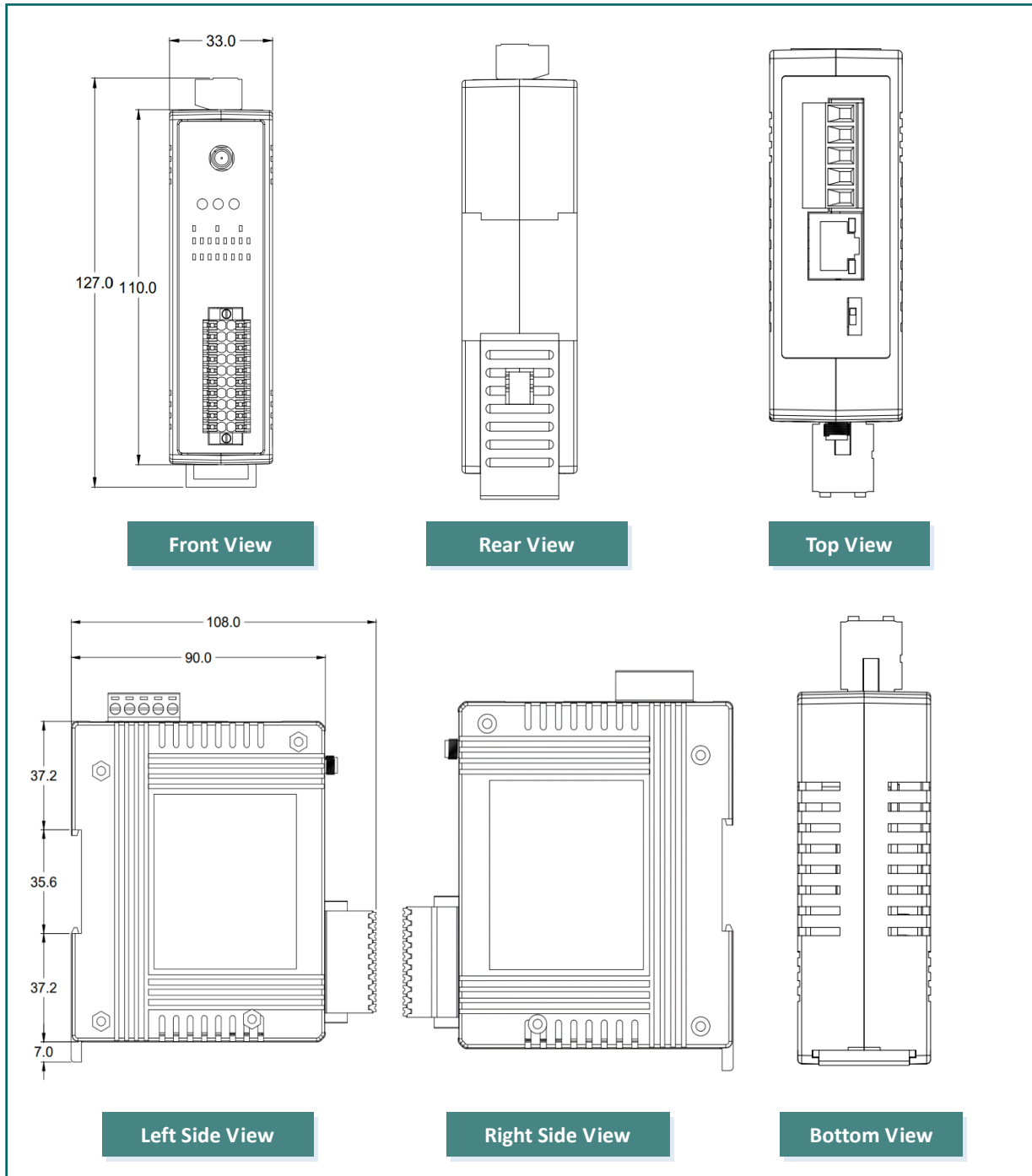

### 3. Getting Started

This chapter provides a basic overview of how to install, configure and operate your SL series module.

#### 3.1 Mounting the Module

The SL series module can be mounted by attaching the bottom of the chassis to a DIN-Rail, or the wall or it can be piggybacked to another module.

##### DIN-Rail Mounting

The SL series modules include simple rail clips on the bottom of the chassis that allow them to be reliably mounted on a DIN-Rail or a wall, or they can be piggybacked to another module. For more detailed information regarding DIN-Rail Mounting, refer to the illustration in figure below.

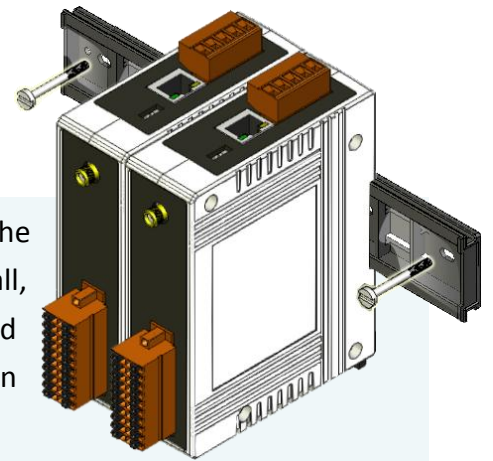

##### Mounting on a DIN-Rail

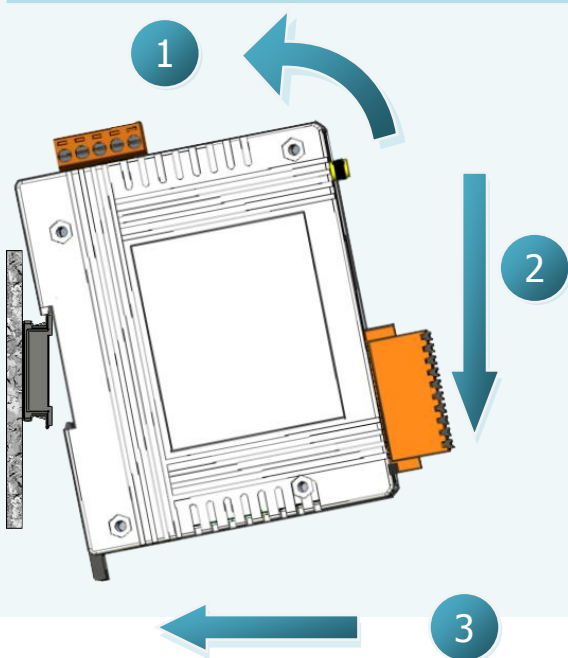

##### Dismounting from a DIN-Rail

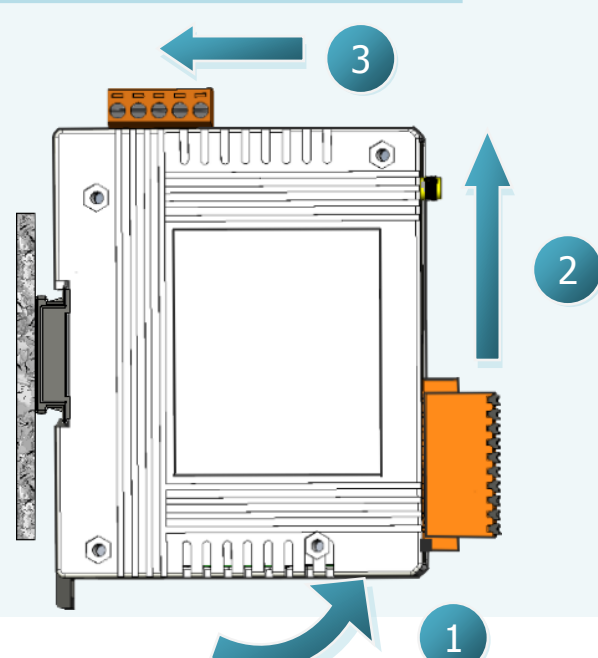

## Mountable DIN-Rail Models

Din-Rail mounts are available in three sizes, and enable a variety of ICP DAS devices to be mounted. Each is made of stainless steel and has a ground wire attached at one end.

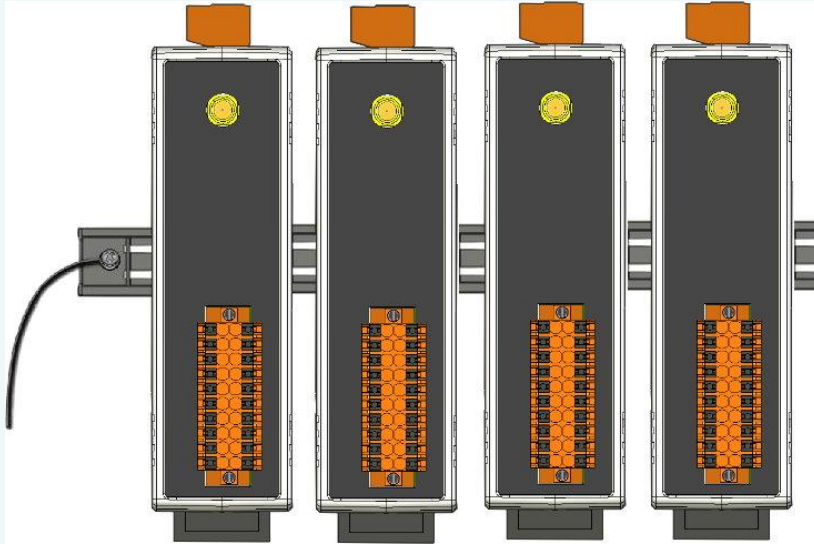

Part Number	Maximum Number of Modules	Dimensions
DRS-125	2	125 mm x 35 mm
DRS-240	3	240 mm x 35 mm
DRS-360	5	360 mm x 35 mm



## 3.2 Configuring the Boot Mode

All SL series modules have two operating modes that can be selected by using the switch mechanism incorporated on the chassis. Note that the module must be rebooted after changing the operating mode.



### Init Mode

Init Mode should only be selected when updating the firmware or while troubleshooting. This mode forces the module to use the default factory settings.

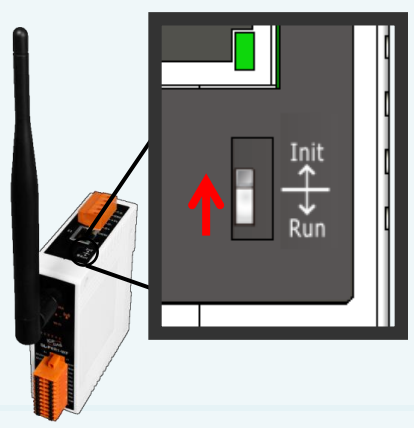



### Run/Normal Mode

Run/Normal Mode is the default operating mode and should be used in most cases.

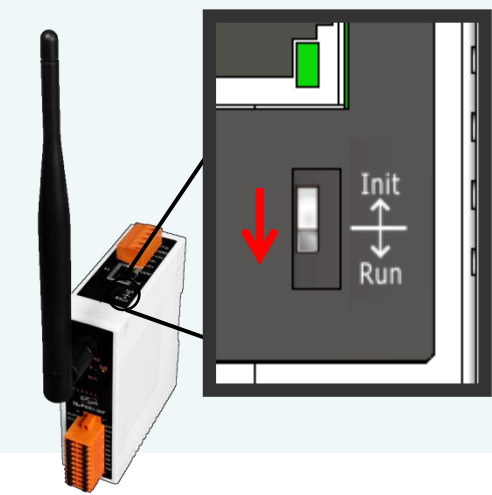

**! Be sure to return the switch to the Run/Normal position once any firmware update is completed.**

### 3.3 Connecting to Wi-Fi, a PC and a Power Supply

All SL series module are equipped with Wi-Fi interface. To configure and test the module via Wi-Fi connection, please refer to chapter 4. Wi-Fi Interface.

The SL device can be configured as station mode, such that the PC/Laptop can be connected through Wi-Fi AP.



The SL device can be configured as AP mode, such that the PC/Laptop can be connected through Wi-Fi directly. Only one device is allowed to be connected to the SL module in AP mode.



### 3.4 Connecting to a Network, a PC and a Power Supply

All SL series module are equipped with an RJ-45 Ethernet port to allow connection to an Ethernet hub/switch or a PC.

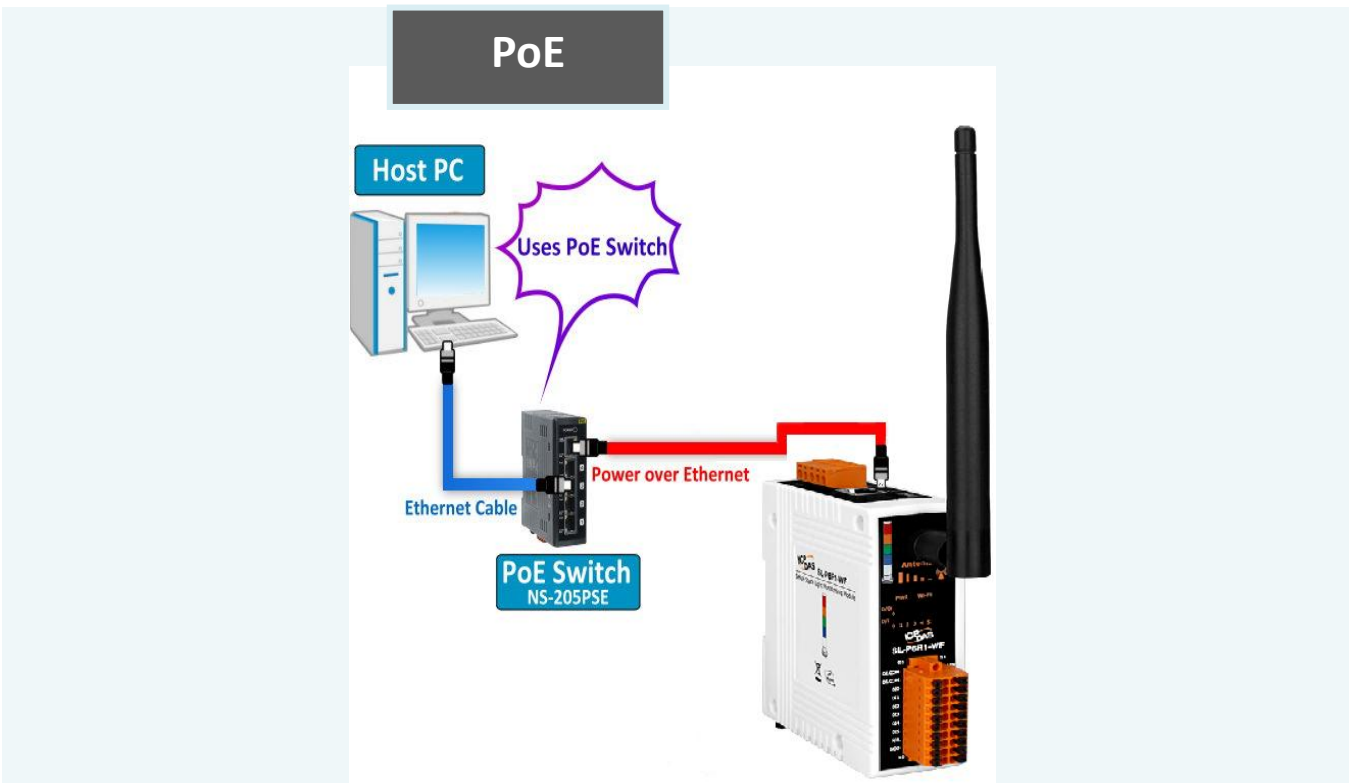
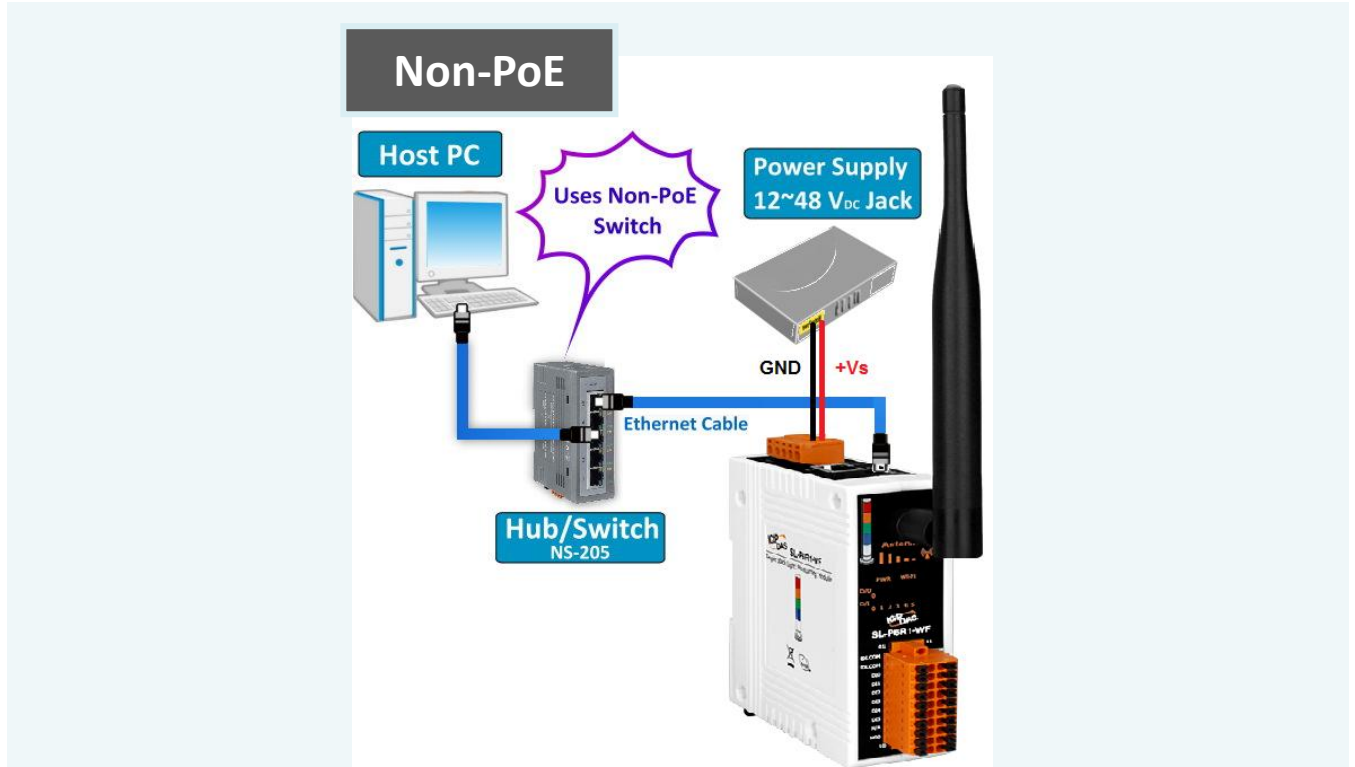

### 3.5 Connecting to RS-485, a PC and a Power Supply

All SL series module are also equipped with an RS-485 port to allow connection to an RS-485 bus. To configure and test the module via RS-485 connection, please refer to chapter 6. RS-485 Interface.

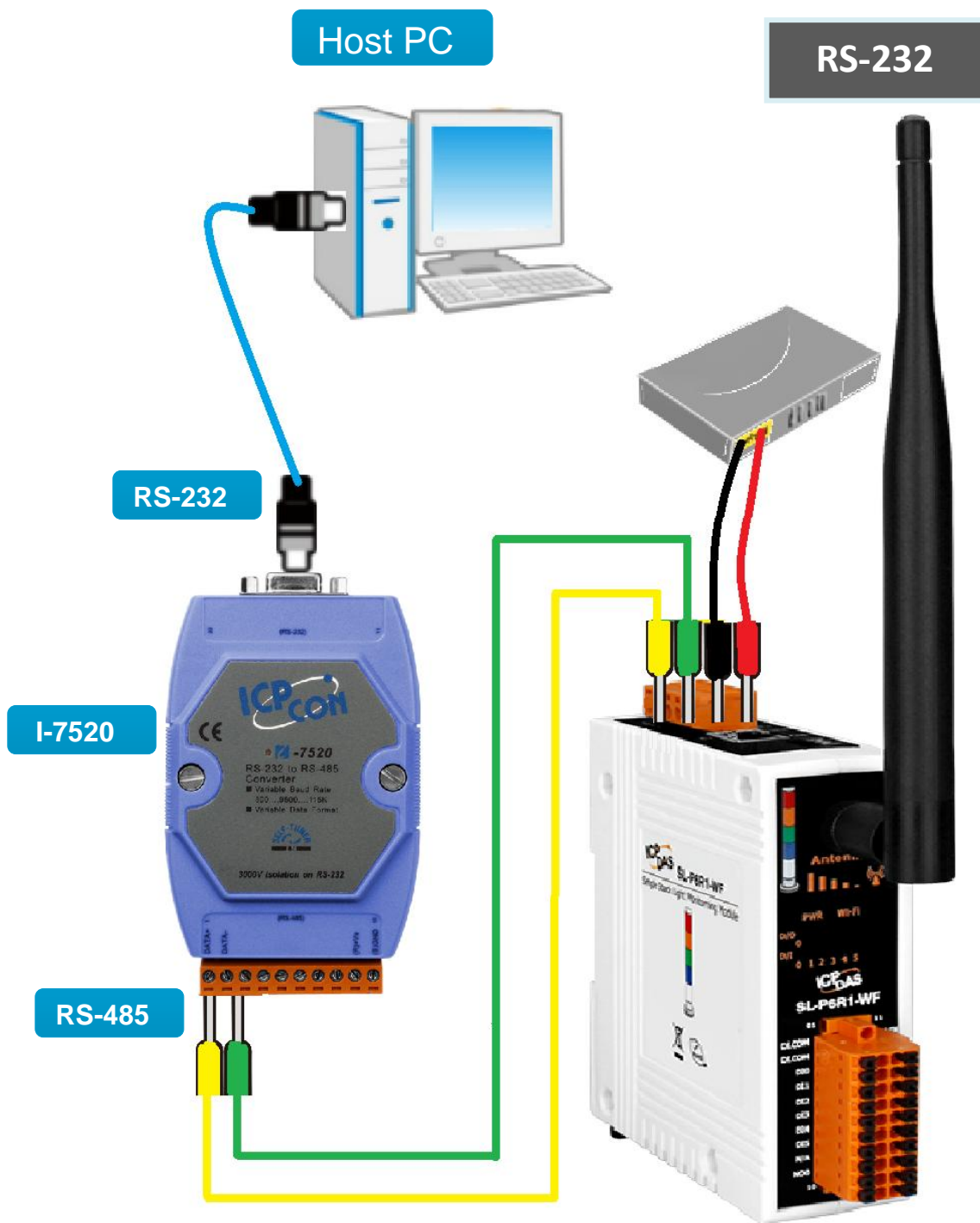

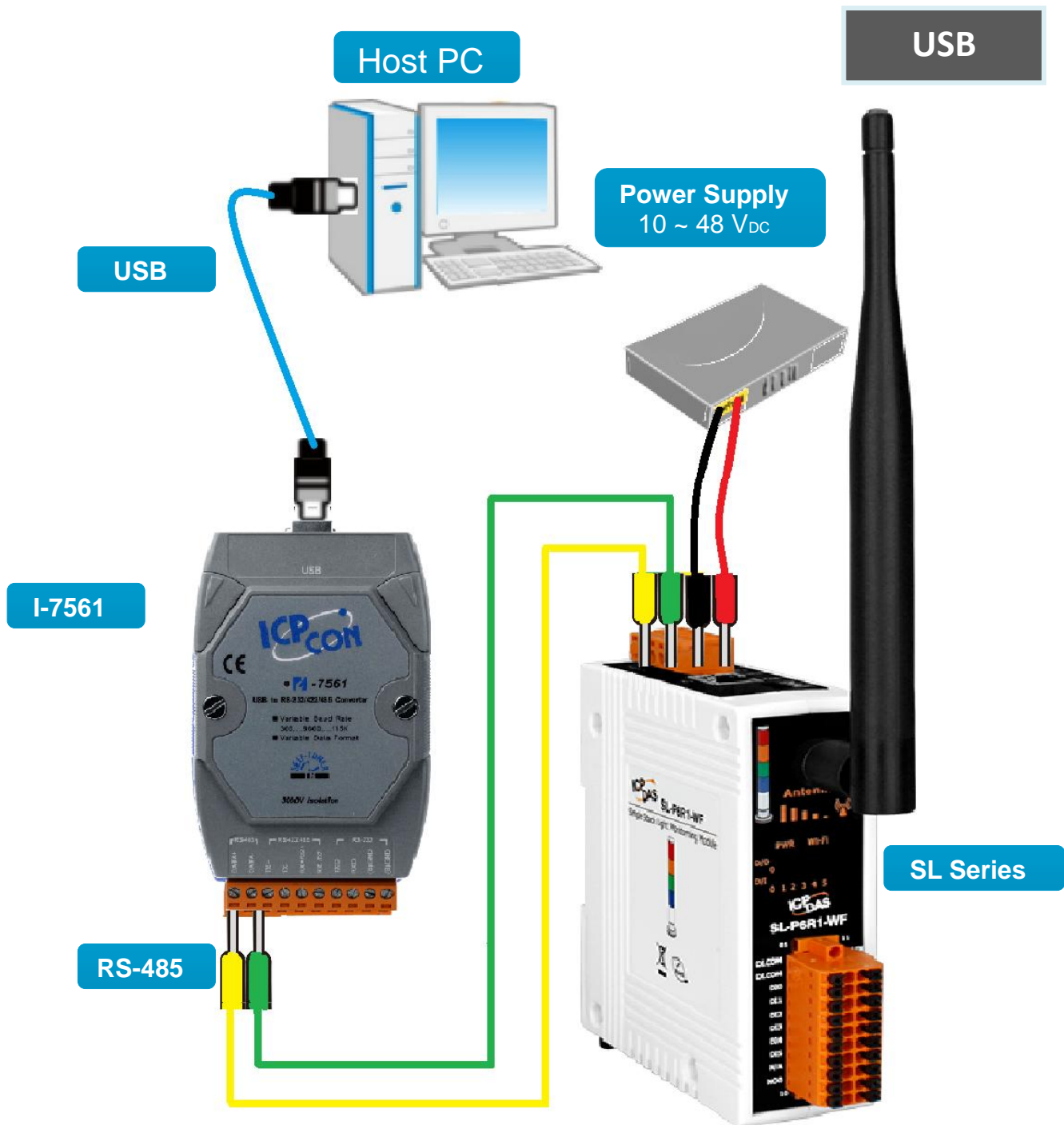

### 3.6 Using the eSearch Utility to Assign a New IP

The eSearch Utility is a useful tool that provides a quick and easy method of configuring the Ethernet settings for SL series module from a PC via the Ethernet interface. Please note that the eSearch Utility cannot be used to configure SL device via the Wi-Fi interface. In this case, use the Wi-Fi IIOT Utility instead.

**Step 1: Get the eSearch Utility tool**

From the ICP DAS web site at:

<http://ftp.icpdas.com/pub/cd/tinymodules/napdos/software/esearch/>

**Step 2: Run the eSearch Utility**

Double-click the eSearch Utility icon.



**Step 3: Click the “Search Servers” button to search for your module**

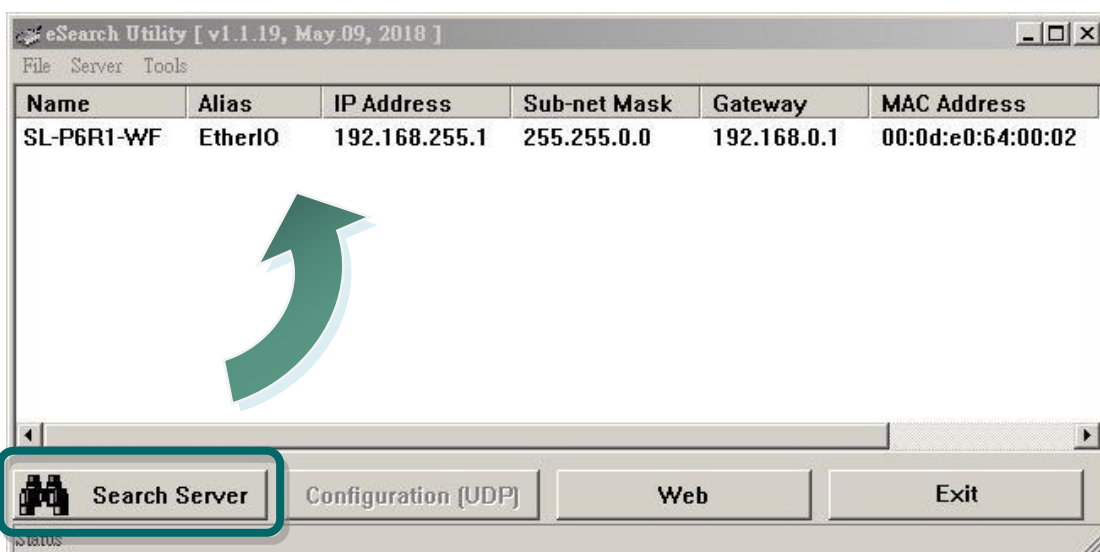

**Step 4: Double-click the name of the module to open the server configuration dialog.**

All SL series modules are IP-based devices that may not be suitable for your network using the default IP address. Therefore, you must first assign a new IP address to the SL series module depending on your network settings.

The factory default IP settings are:

IP Address: 192.168.255.1; Subnet Mask: 255.255.0.0; Gateway: 192.168.0.1.

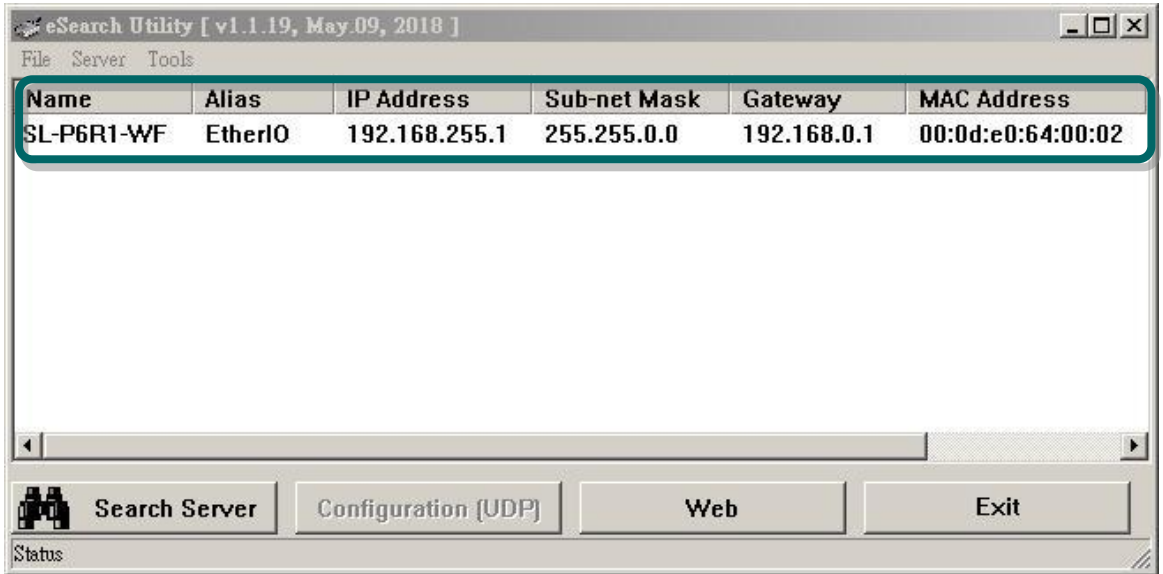

**Step 5: Assign a new IP address and then click the “OK” button.**

Contact your Network Administrator to obtain the correct network configuration information. Modify the network settings as necessary and then click the “OK” button. The SL series module will use the new settings immediately.

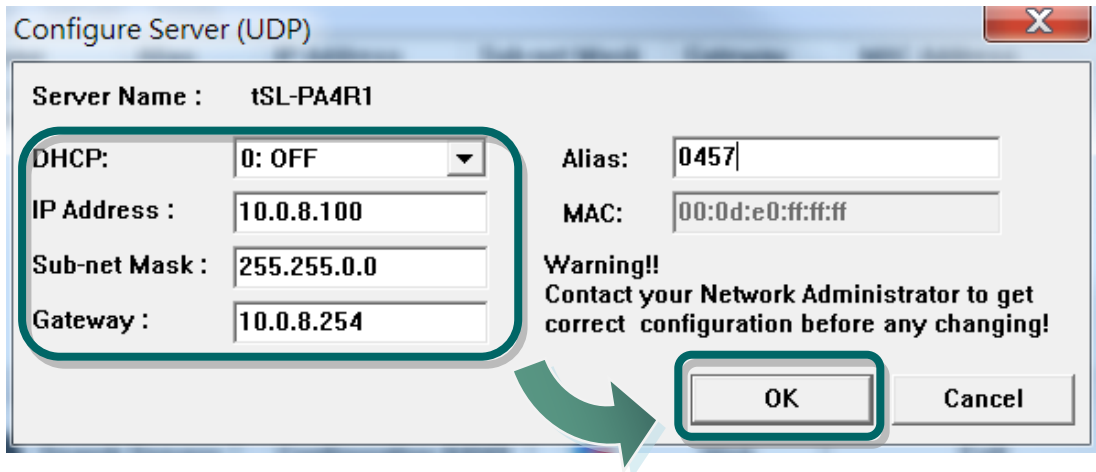



## 4. Wi-Fi Configuration

The WiFi IIOT Utility is provided to configure and test the SL module through the Wi-Fi interface.

### 4.1 Install WiFi IIOT Utility

The installation file location of the WiFi IIOT Utility is at:

[http://ftp.icpdas.com/pub/cd/8000cd/napdos/driver/WiFi\\_IIOT\\_UTILITY/](http://ftp.icpdas.com/pub/cd/8000cd/napdos/driver/WiFi_IIOT_UTILITY/)

### 4.2 Search and Find the Module

Click on the search button to find the modules via the Wi-Fi interface.

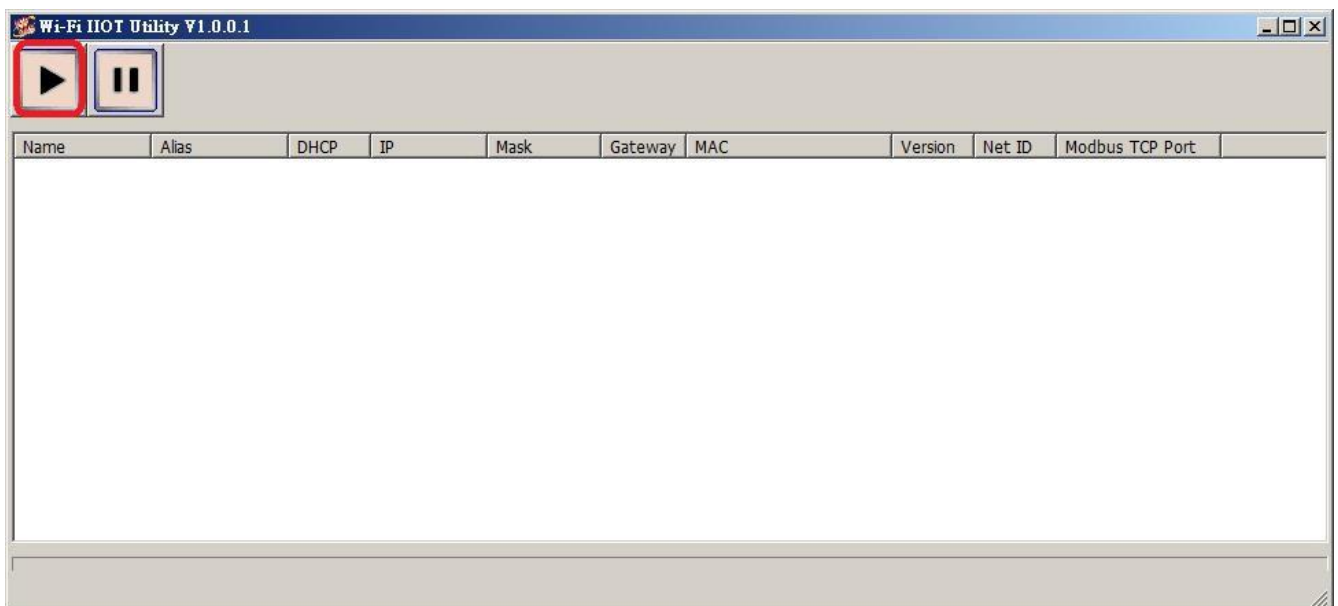

Select the Wi-Fi network interface and click on the OK button.

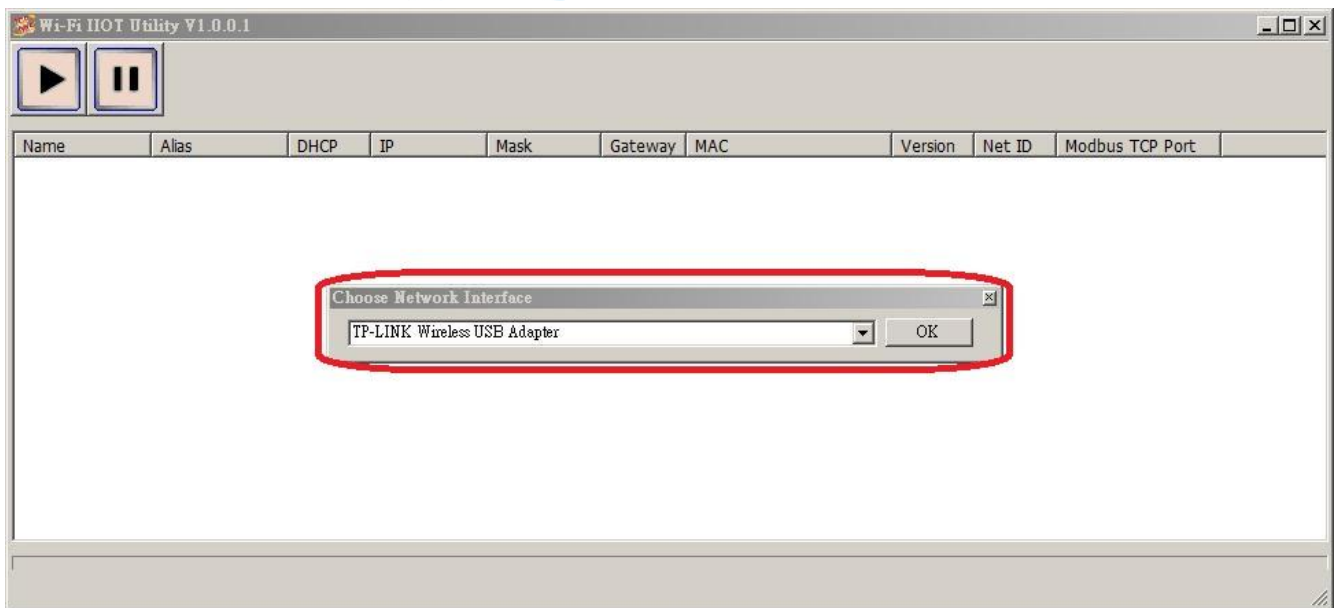

## 4.3 Configure and Test the Module

When the module is found, click on the module name to enter the configuration form.

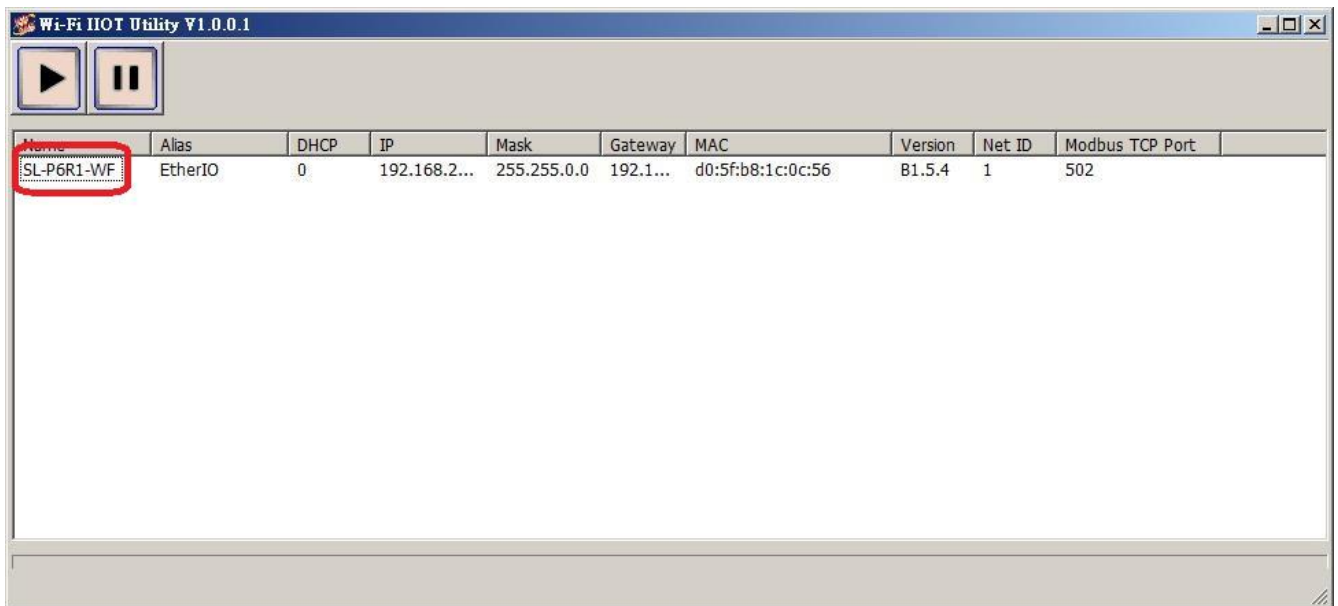

In the configuration form, you can change the Wi-Fi related settings. Click on the Set Module Configurations button to save the changes to the module.

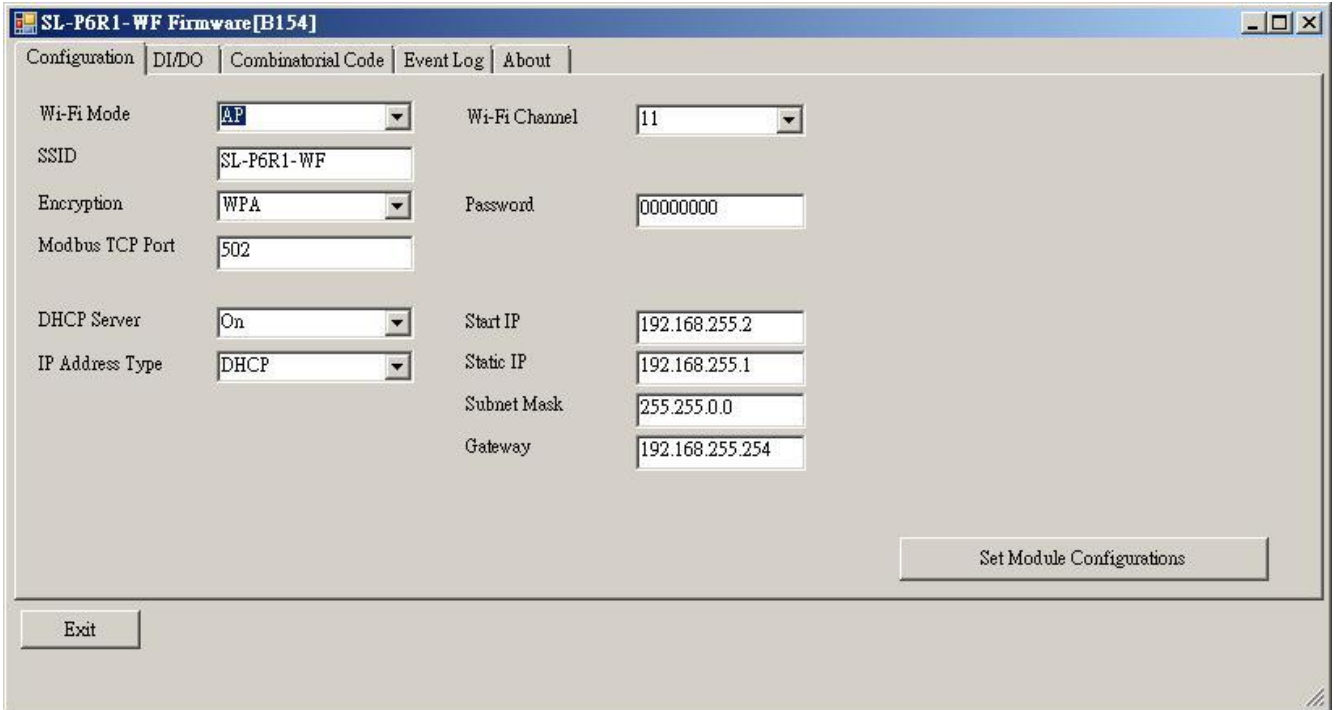

The followings show the detailed description of each setting.

Item	Description
WiFi Mode	This parameter is used to specify the Wi-Fi mode of the SL device. It can be Station or AP. For AP mode, only one device can be connected.
Encryption	This parameter is used to specify which security protocol is used to secure wireless computer network. It can be open, WEP, or WPA. It is recommended to use WPA if possible.
DHCP Server	This parameter is used to specify whether to turn on the DHCP server function. It is only available to the AP mode.
WiFi Channel	This parameter is used to specify which channel is used for Wi-Fi transmission. It can be 1 to 11. It is only available to the AP mode.
IP Address Type	This parameter is only available to the station mode and it can be Static or DHCP. If DHCP is supported by the AP you would like to connect, then DHCP should be selected. Otherwise, select Static and the following three parameters Static IP, Subnet Mask and Gateway should be set, too.

Static IP	Each SL device connected to the Wi-Fi network must have its own unique IP address. This parameter is used to assign a specific IP address.
Subnet Mask	This parameter is used to assign the subnet mask for the SL device. The subnet mask indicates which portion of the IP address is used to identify the local network or subnet.
Gateway	This parameter is used to assign the IP address of the gateway to be used by the SL device. A gateway (or router) is a device that is used to connect an individual network to one or more additional networks.
SSID	This parameter is used to specify the Service Set Identifier. For station mode, specify the SSID of the AP you would like to connect. For AP mode, the SSID will be used by the device to be connected.
Modbus TCP Port	This parameter is used to set the local port of the Wi-Fi interface to be used by the Modbus slave device. The default value is 502.

The following table provides an overview of the factory default Wi-Fi settings:

Factory Default Wi-Fi Settings	
Mode	AP
Wireless Security	WPA, "00000000"
DHCP Server (AP Mode)	DHCP Server on, start IP: 192.168.255.2
Wi-Fi Channel (AP Mode)	11
IP Address	192.168.255.1
Gateway Address	192.168.255.254
Subnet Mask	255.255.0.0
SSID	SL-P6R1-WF or SL-PA6R1-WF
Modbus TCP Port	502

Click on the DI/DO tab, you can turn on/off the digital output and get the status of the stack lights, including the combinatorial status value and the time of the previous state.

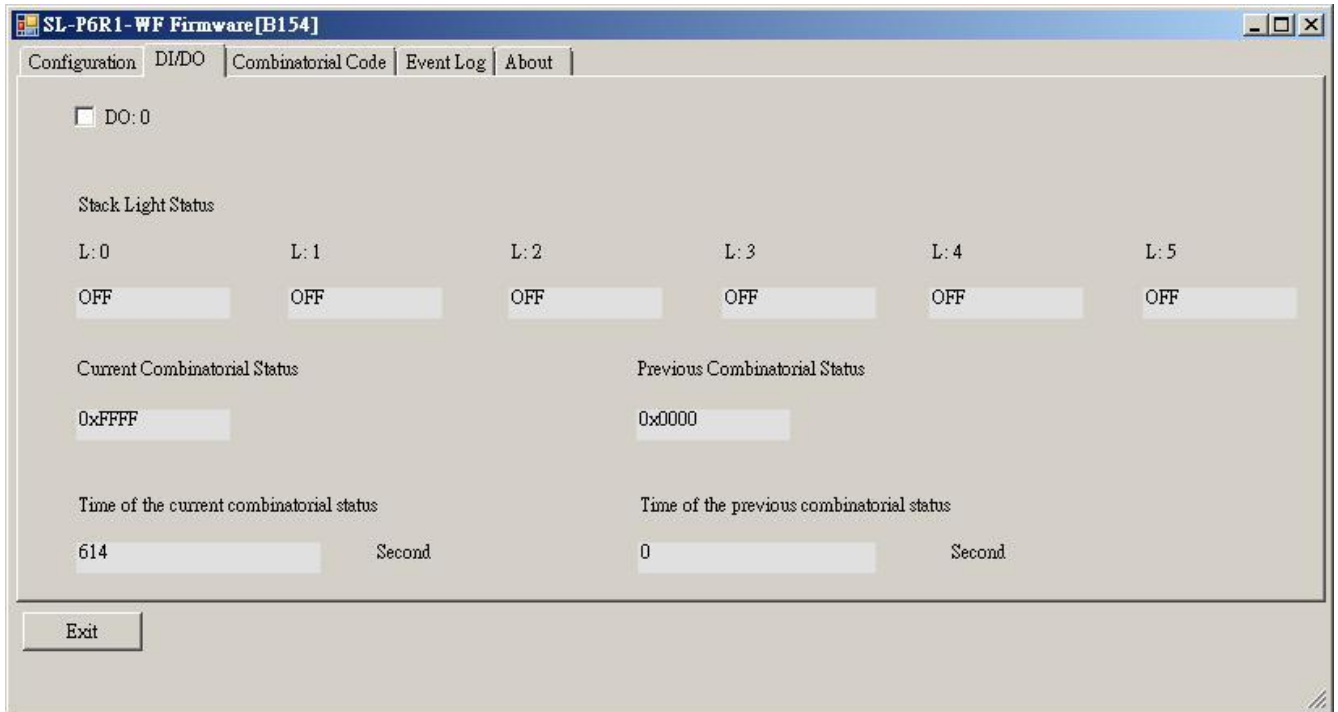

Click on the Combinatorial Code tab, you can change the combinatorial value settings.

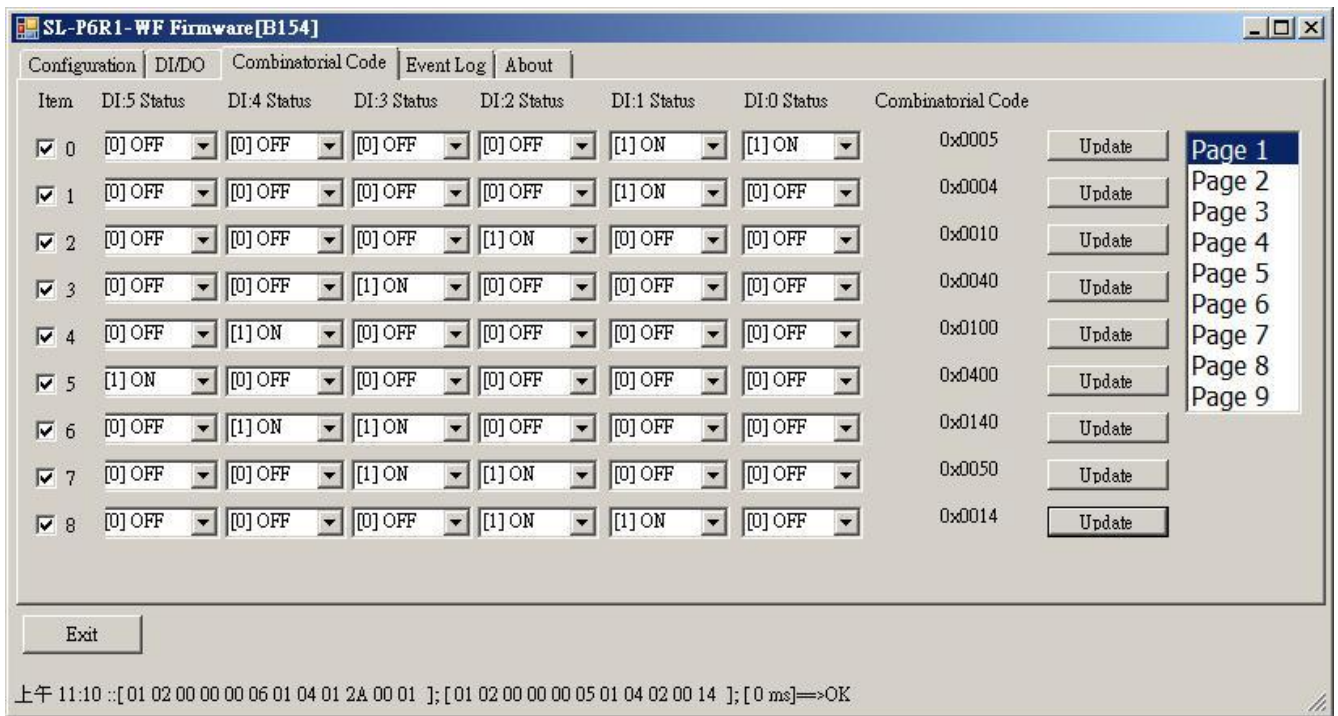

## 5. Web Configuration

All SL series module contain an advanced embedded web configuration system that provides I/O accessibility to the SL series module via a web browser. **Please note that the web configuration is only available to the Ethernet interface.**

### Logging in to the SL Web Server

You can access the embedded SL series web server from any computer that has an Internet connection.

**Step 1: Open a new browser window.**

Open a standard web browser. For example, Mozilla Firefox, Google Chrome and Internet Explorer are reliable and popular internet browsers that can be used to configure SL series module.



Note that if you intend to use Internet Explorer, ensure that the cache to functions is disabled in order to avoid browser access errors. Detailed information how to do this can be found in “Appendix: A”.

**Step 2: Enter the URL address of the SL web server.**

Ensure that you have correctly configured the network settings for the SL series module, or refer to [Section 3.6 “Using the eSearch Utility to Assign a New IP”](#).

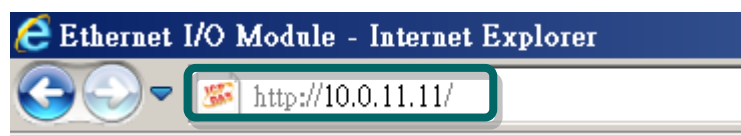

**Step 3: Enter the password**

After entering the IP address, the main login dialog page will be displayed prompting you to enter a password. The factory default password is “Admin”. Click the “Submit” button to continue.



**Step 4: Log in to the SL web server**

After logging into the SL web server, the main page will be displayed.

Model Name:	SL-P6R1-WF	Alias Name:	EtherIO
Firmware Version:	B1.5.4 [Aug.14, 2018]	MAC Address:	00-0D-E0-64-00-02
IP Address:	10.0.11.11	Initial Switch:	OFF
TCP Port Timeout: (Socket Watchdog, Seconds):	180	System Timeout: (Network Watchdog, Seconds)	0

**Stack Light Status**

Input 0	Off
Input 1	Off
Input 2	Off
Input 3	Off
Input 4	Off
Input 5	Off
Current Combinatorial Status Value	65535
Previous Combinatorial Status Value	0
Current Combinatorial Status Time (Seconds)	403
Previous Combinatorial Status Time (Seconds)	0



## 5.1 Home Page

Clicking the **Home** tab will display to the main **status & Configuration** page, which is divided into three sections.



The first section provides basic information related to the SL series module hardware and software including the firmware version and IP address, etc.

Model Name:	SL-P6R1-WF	Alias Name:	EtherIO
Firmware Version:	B1.5.4 [Aug.14, 2018]	MAC Address:	00-0D-E0-64-00-02
IP Address:	10.0.11.11	Initial Switch:	OFF
TCP Port Timeout: (Socket Watchdog, Seconds):	180	System Timeout: (Network Watchdog, Seconds)	0

The second section provides information of the stack light status.

### Stack Light Status

Input 0	Off
Input 1	Off
Input 2	Off
Input 3	Off
Input 4	Off
Input 5	Off
Current Combinatorial Status Value	65535
Previous Combinatorial Status Value	0
Current Combinatorial Status Time (Seconds)	949
Previous Combinatorial Status Time (Seconds)	0

Item	Description
Input 0	The monitored stack light status of the input channel 0. It can be On/Off/Blinking.
Input 1	The monitored stack light status of the input channel 1. It can be On/Off/Blinking.
Input 2	The monitored stack light status of the input channel 2. It can be On/Off/Blinking.
Input 3	The monitored stack light status of the input channel 3. It can be On/Off/Blinking.
Input 4	The monitored stack light status of the input channel 4. It can be On/Off/Blinking.
Input 5	The monitored stack light status of the input channel 5. It can be On/Off/Blinking.
Current Combinatorial Status Value	Combinatorial status of the monitored stack lights. For details regarding combinatorial status, please refer to 5.5.2 Combinatorial Table Settings.
Previous Combinatorial Status Value	The previous combinatorial status of the monitored stack lights. For details regarding combinatorial status, please refer to 5.5.2 Combinatorial Table Settings.
Current Combinatorial Status Time (Seconds)	Time of the Current combinatorial status of the monitored stack lights in seconds.
Previous Combinatorial Status Time (Seconds)	Time of the previous combinatorial status of the monitored stack lights in seconds.

The third section provides status of the digital output and you can click on the button to toggle the digital output.

**Digital Output**



## 5.2 Network Settings

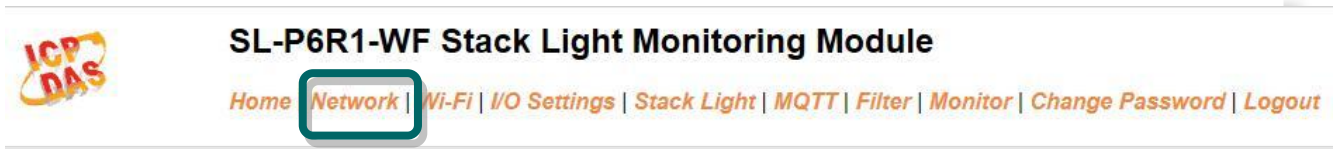

Clicking the **Network** tab will display the **Network and Miscellaneous Settings** page allowing you verify the current settings and configure the IP address parameters, configure the general parameters and restore the default settings for the SL device, each of which will be described in more detail below.

### 5.2.1 Network and Miscellaneous Settings

The **Network and Miscellaneous Settings** page allows you to check the model name and other information related to the hardware and software.

Model Name:	SL-P6R1-WF	Alias Name:	EtherIO
Firmware Version:	B1.5.4 [Aug. 14, 2018]	MAC Address:	00-0D-E0-64-00-02
IP Address:	10.0.11.11	Initial Switch:	OFF
TCP Port Timeout: (Socket Watchdog, Seconds):	180	System Timeout: (Network Watchdog, Seconds)	0

The software and hardware information section includes the following items:

The model name, firmware version, IP address, initial switch position, alias name, MAC address, and the TCP port timeout and system timeout values. If the firmware for the SL device is updated, you can use this page to check the version information for the SL firmware.

## 5.2.2 IP Address Configuration

### IP Address Configuration

Address Type:	DHCP <input type="button" value="v"/>		
Static IP Address:	<input type="text" value="0"/>	<input type="text" value="0"/>	<input type="text" value="0"/>
Subnet Mask:	<input type="text" value="0"/>	<input type="text" value="0"/>	<input type="text" value="0"/>
Default Gateway:	<input type="text" value="0"/>	<input type="text" value="0"/>	<input type="text" value="0"/>
MAC Address:	<input type="text" value="00-0d-e0-64-4c-d3"/> (Format: FF-FF-FF-FF-FF-FF)		
	<a href="#">Modbus TCP Slave</a>		
Local Modbus TCP port	<input type="text" value="502"/> (Default= 502)		
Local Modbus NetID	<input type="text" value="1"/> (Default= 1)	<input type="button" value="Enable"/> <input type="button" value="v"/>	(Default= Enable)
<input type="button" value="Update Settings"/>			

The following table provides an overview of the parameters contained in the IP address configuration section:

Item	Description
Address Type	<p><b>Static IP:</b> If there is no DHCP server installed in your network, you can configure the network settings manually. Refer to <a href="#">Section “5.2.2.2 Manual Configuration”</a> for more details.</p> <p><b>DHCP:</b> Dynamic Host Configuration Protocol (DHCP) is a network application protocol that automatically assigns an IP address to each device. Refer to <a href="#">Section “5.2.2.1 Dynamic Configuration”</a> for more details.</p>
Static IP Address	Each SL device connected to the network must have its own unique IP address. This parameter is used to assign a specific IP address.
Subnet Mask	This parameter is used to assign the subnet mask for the SL device. The subnet mask indicates which portion of the IP address is used to identify the local network or subnet.
Default Gateway	This parameter is used to assign the IP address of the gateway to be used by the SL device. A gateway (or router) is a device that is used to connect an individual network to one or more additional networks.
MAC Address	This parameter is used to set the user-defined MAC address, which must be in the format FF-FF-FF-FF-FF-FF.

Modbus TCP Slave	
Local Modbus TCP port	This parameter is used to set the local port to be used by the Modbus slave device. The default value is 502.
Local Modbus Net ID	This parameter is used to set the network ID to be used by the Modbus slave device. The default value is 1.
Update Settings	Click this button to save the revised settings to the SL device.

### 5.2.2.1 Dynamic Configuration

Dynamic configuration is very easy to perform. If a DHCP server is connected to you network, a network address can be dynamically configured by using the following procedure:

**Step 1:** Select “DHCP” from the **Address Type** drop-down menu.

**Step 2:** Click the “Update Settings” button to complete the configuration.

#### IP Address Configuration

Address Type:	DHCP	1
Static IP Address:	0 . 0 . 0 . 0	
Subnet Mask:	0 . 0 . 0 . 0	
Default Gateway:	0 . 0 . 0 . 0	
MAC Address:	00-08-e0-64-4c-d3	(Format: FF-FF-FF-FF-FF-FF)
<a href="#">Modbus TCP Slave</a>		
Local Modbus TCP port	502	(Default= 502)
Local Modbus NetID	1	(Default= 1) Enable (Default= Enable)
Update Settings		2

## 5.2.2.2 Manual Configuration

When using manual configuration, the network settings should be assigned in the following manner:

**Step 1:** Select “**Static IP**” from the **Address Type** drop-down menu.

**Step 2:** Enter the relevant details in the respective **network settings** fields.

**Step 3:** Click the “**Update Settings**” button to complete the configuration.

Address Type:	Static IP	1
Static IP Address:	10 . 0 . 8 . 100	2
Subnet Mask:	255 . 255 . 255 . 0	
Default Gateway:	10 . 0 . 8 . 254	
MAC Address:	00-0d-e0-64-4c-d3	(Format: FF-FF-FF-FF-FF-FF)
		Modbus TCP Slave
Local Modbus TCP port:	502	(Default= 502)
Local Modbus NetID:	1	(Default= 1) Enable (Default= Enable)
	Update Settings	3

## 5.2.3 General Configuration Settings

### General Settings

Ethernet Speed:	Auto <input type="button" value="v"/> (Auto=10/100 Mbps Auto-negotiation)
System Timeout: (Network Watchdog)	0 (30 ~ 65535 s, Default= 0, Disable= 0) Action:Reboot
TCP Timeout:	180 (5 ~ 65535 s, Default= 180, Disable= 0) Action:Cut-off
Web Auto-logout:	10 (1 ~ 65535 minutes, Default= 10, Disable= 0)
Alias Name:	0457 (Max. 18 chars)
<input type="button" value="Update Settings"/>	

The following table provides an overview of the parameters contained in the General Settings section:

Item	Description
Ethernet Speed	This parameter is used to set the Ethernet speed. The default value is Auto (Auto = 10/100 Mbps Auto-negotiation).
System Timeout (Network Watchdog)	This parameter is used to configure the system timeout value. If there is no activity on the network for a certain period of time, the system will be rebooted based on the configured system timeout value.
TCP Timeout (Seconds)	This parameter is used to configure the TCP timeout value. If Modbus TCP communication is idle for a certain period of time, the system will cut off the connection.
Web Auto-logout	This parameter is used to configure the automatic logout value. If there is no activity on the web server for a certain period of time, the current user account will be logged out automatically.
Alias Name	This parameter is used to assign an alias name for each SL device to assist with easy identification.
Update Settings	Click this button to save the revised settings to the SL device.

## 5.2.4 Restoring Factory Defaults

### Restore Factory Defaults

<b>Restore all options to their factory default states:</b>	<input type="button" value="Restore Defaults"/>
<b>Forced Reboot</b>	<input type="button" value="Reboot"/>

■ To reset all parameters to their original factory default settings, use the following procedure:

**Step 1:** Click the “Restore Defaults” button to reset the configuration.

**Step 2:** Click the “OK” button in the message dialog box.

**Step 3:** Check whether the module has been reset to the original factory default settings for use with the eSearch Utility. Refer to [Section 3.5 Using the eSearch Utility to assign a new IP](#)”.

### Restore Factory Defaults

Name	Alias	IP Address
IPET-C4	EtherIO	192.168.255.1



The following table provides an overview of the factory default settings:

Factory Default Settings	
Network Settings	
IP Address	192.168.255.1
Gateway Address	192.168.0.1
Subnet Mask	255.255.0.0
DHCP	Disabled
Basic Settings	
Alias Name	EtherIO

- The Forced Reboot function: can be used to force the SL device to reboot or to remotely reboot for the device. After the SL module has rebooted, the original login screen will be displayed requesting that you enter your login password before continuing.



**The system is logged out.**

To enter the web configuration, please type password in the following field.

Login password:

When using IE, please disable its cache as follows.

Menu items: Tools / Internet Options... / General / Temporary Internet Files / Settings... / Every visit to the page

## 5.3 Wi-Fi Settings



### SL-P6R1-WF Stack Light Monitoring Module

Home | Network | **Wi-Fi** | I/O Settings | Stack Light | MQTT | Filter | Monitor | Change Password | Logout

Clicking the **Wi-Fi** tab will display the **Wi-Fi** page allowing you configure the Wi-Fi parameters for the SL device. This page including Wi-Fi Status and Wi-Fi Settings, each of which will be described in more detail below.

### 5.3.1 Wi-Fi Status

#### Wi-Fi Status

Connection Status	Connected
Signal Strength	High
MAC Address	D0-5F-B8-1C-0C-56
IP Address	192.168.0.100

Update Wi-Fi Status

The following table provides an overview of the parameters contained in the Wi-Fi Status section:

Item	Description
Connection Status	The Wi-Fi connection status of the SL device.
Signal Strength	The Wi-Fi signal strength of the SL device in station mode. It can be High, Medium, Low, or Not Connected.
MAC Address	The MAC address of the Wi-Fi interface of the SL device.
IP Address	The IP address of the Wi-Fi interface of the SL device.
Update Wi-Fi Status	Click this button to update the Wi-Fi status of the SL device.

## 5.3.2 Wi-Fi Settings

### Wi-Fi Settings

Wi-Fi Settings	Current	New
Mode	Station	Station <input type="button" value="v"/> Default: AP
Wireless Security	WPA/WPA2, *****	WPA/WPA2 <input type="button" value="v"/> Password: <input type="password" value="....."/> (Max. 63 chars)
DHCP Server (AP Mode)	On, 192.168.255.2	On <input type="button" value="v"/> Start IP: <input type="text" value="192"/> . <input type="text" value="168"/> . <input type="text" value="255"/> . <input type="text" value="2"/>
Wi-Fi Channel (AP Mode)	11	11 <input type="button" value="v"/>
IP Address Type (Station Mode)	DHCP	DHCP <input type="button" value="v"/>
IP Address	192.168.0.100	<input type="text" value="192"/> . <input type="text" value="168"/> . <input type="text" value="255"/> . <input type="text" value="1"/>
Subnet Mask	0.0.0.0	<input type="text" value="255"/> . <input type="text" value="255"/> . <input type="text" value="0"/> . <input type="text" value="0"/>
Gateway	192.168.0.1	<input type="text" value="192"/> . <input type="text" value="168"/> . <input type="text" value="255"/> . <input type="text" value="254"/>
SSID	WR841NV13	WR841NV13 (Max. 32 chars)
Modbus TCP port	502	<input type="text" value="502"/> (Default= 502)
<input type="button" value="Update Settings"/>		

The column of Current shows the current Wi-Fi settings. You can change the settings by changing the column of New. The following table provides an overview of the parameters contained in the Wi-Fi Settings section:

Item	Description
Mode	This parameter is used to specify the Wi-Fi mode of the SL device. It can be station or AP. For AP mode, only one device can be connected.
Wireless Security	This parameter is used to specify which security protocol is used to secure wireless computer network. It can be open, WEP, or WPA/WPA2. It is recommended to use WPA/WPA2 if possible.
DHCP Server (AP Mode)	This parameter is used to specify whether to turn on the DHCP server function. It is only available to the AP mode.
Wi-Fi Channel (AP Mode)	This parameter is used to specify which channel is used for Wi-Fi transmission. It can be 1 to 11. It is only available to the AP mode.
IP Address Type (Station Mode)	This parameter is only available to the station mode and it can be Static IP or DHCP. If DHCP is supported by the AP you would like to connect, then DHCP should be selected. Otherwise, select Static IP and the following three parameters IP Address, Subnet Mask and Gateway should be set, too.

IP Address	Each SL device connected to the Wi-Fi network must have its own unique IP address. This parameter is used to assign a specific IP address.
Subnet Mask	This parameter is used to assign the subnet mask for the SL device. The subnet mask indicates which portion of the IP address is used to identify the local network or subnet.
Gateway	This parameter is used to assign the IP address of the gateway to be used by the SL device. A gateway (or router) is a device that is used to connect an individual network to one or more additional networks.
SSID	This parameter is used to specify the Service Set Identifier. For station mode, specify the SSID of the AP you would like to connect. For AP mode, the SSID will be used by the device to be connected.
Modbus TCP Port	This parameter is used to set the local port of the Wi-Fi interface to be used by the Modbus slave device. The default value is 502.
Update Settings	Click this button to save the revised settings to the SL device.

The following table provides an overview of the factory default Wi-Fi settings:

Factory Default Wi-Fi Settings	
Mode	AP
Wireless Security	WPA/WPA2, "00000000"
DHCP Server (AP Mode)	DHCP Server on, start IP: 192.168.255.2
Wi-Fi Channel (AP Mode)	11
IP Address	192.168.255.1
Gateway Address	192.168.255.254
Subnet Mask	255.255.0.0
SSID	SL-P6R1-WF or SL-PA6R1-WF
Modbus TCP Port	502

## 5.4 I/O Settings



Clicking the **I/O Settings** tab will display the **I/O Settings** page allowing you configure the Digital Input and Digital Output parameters for the SL device. This page including Digital Output control and DI/DO Configuration, each of which will be described in more detail below.

### 5.4.1 DO Control

#### DO Control

Digital Output	Setting
Value	<input type="text" value="0x0"/> Ch 0( <input type="checkbox"/> )
<input type="button" value="Update Settings"/>	

The following table provides an overview of the parameters contained in the Digital Output Control section:

Item	Description
Value	This parameter is used to manually assign a specific a value for the DO.
Update Settings	Click this button to save the revised settings to the SL device.

## 5.4.2 DI/DO Configuration

### DI/DO Configuration:

Digital Output	Setting
Host/Slave Watchdog Timeout	<input type="text" value="0"/> (10 ~ 65535 Seconds, Default= 0, Disable= 0) Outputs DO with safe-value when host/slave timeout.
Safe Value	<input type="text" value="0x0"/> Ch 0( <input type="checkbox"/> )
Power-On Value	<input type="text" value="0x0"/> Ch 0( <input type="checkbox"/> )
Digital Input	Setting
DI Filter Time	<input type="text" value="0"/> (1 ~ 6500 ms, Default= 0, Disable= 0)
<input type="button" value="Update Settings"/>	

The following table provides an overview of the parameters contained in the DI/DO Configuration section:

Item	Description
<b>Digital Output</b>	
Host Watchdog Timeout (Seconds)	This parameter is used to configure the Host Watchdog timeout value. If there is no Modbus TCP communication activity for the specified period (the timeout), then the Host Watchdog will activate an alarm.
Safe Value	This parameter is used to define the DO safe value for the SL module. If the Host Watchdog alarm is activated, the DO will be set to the user-defined safe value.
Power-On Value	This parameter is used to define the DO Power-on value. On boot up, the DO is set to the user-defined Power-on value.
<b>Digital Input</b>	
DI Filter Time (ms)	The DI filter is a function that eliminates high-frequency noise from inputs. 0 = Disable. Refer to “Appendix: FAQ F” for more detailed information. <b>This parameter is only available to the SL-P6R1-WF module.</b>
Update Settings	Click this button to save the revised settings of DI/DO configuration to the SL device.

## 5.5 Stack Light



### SL-P6R1-WF Stack Light Monitoring Module

[Home](#) | [Network](#) | [Wi-Fi](#) | [I/O Settings](#) | **[Stack Light](#)** | [MQTT](#) | [Filter](#) | [Monitor](#) | [Change Password](#) | [Logout](#)

Clicking the **Stack Light** tab will display the **Stack Light Configuration** page allowing you to configure the stack light parameters for the SL device, including the stack light and combinatorial table, each of which will be described in more detail below.

### 5.5.1 Stack Light Settings

#### Stack Light Settings

Checking Interval Period	<input type="text" value="50"/> (10 ~ 65500 ms, in 10 ms step, Default= 50)
Number of Checking Interval	<input type="text" value="50"/> (1 ~ 256, Default= 50)
<input type="button" value="Update Settings"/>	

The following table provides an overview of the parameters contained in the Stack Light Settings section:

Item	Description	Default Value
Checking Interval Period (ms)	This parameter is used to set the interval period to check whether there is an on/off change in the input channel during the period. The value should be in 10ms step.	50
Number of Checking Interval	This parameter is used to set the number of checking interval parameter, N. If there is no on/off change in the recent N/2 checking intervals, then the state of the input channel is set to on or off state. Otherwise, if there are on/off change happened in four or more of the recent N checking intervals, then the state of the input channel is set to blinking.	50
Update Settings	Click this button to save the revised settings to the SL device.	

## 5.5.2 Combinatorial Table Settings

### Combinatorial Table Settings

Value	Enabled	Inputs
0	Disabled	In0 Off In1 Off In2 Off In3 Off In4 Off In5 Off
1	Disabled	In0 Off In1 Off In2 Off In3 Off In4 Off In5 Off
2	Disabled	In0 Off In1 Off In2 Off In3 Off In4 Off In5 Off
3	Disabled	In0 Off In1 Off In2 Off In3 Off In4 Off In5 Off
4	Disabled	In0 Off In1 Off In2 Off In3 Off In4 Off In5 Off
5	Disabled	In0 Off In1 Off In2 Off In3 Off In4 Off In5 Off
6	Disabled	In0 Off In1 Off In2 Off In3 Off In4 Off In5 Off
Update Settings		

The various stack light colors provide the machine status information. Followings are example to show the machine status associated with the light colors. Each status is assigned with a unique value by setting the combinatorial table, such that the machine status can be obtained by just reading the combinatorial status value.

Combinatorial Status	Red	Yellow	Green	Blue
machine off (value=0)	off	off	off	off
machine running (value=1)	off	off	on	off
machine down (value=2)	on	off	off	Off
out of material (value=3)	flashing	off	off	Off
low material (value=4)	off	on	off	off
test-in-process (value=5)	off	flashing	off	off
manual mode active (value=6)	off	off	flashing	off
waiting for service call (value=7)	off	off	off	on

To assign light colors to value 0 to 6, click on the 0~6 tab, 7~13 tab for values 7 to 13, etc. When a value is to be assigned, the value should be set to “Enabled” and set the off/on/blinking status of each input channel.



## 5.6 MQTT



### SL-P6R1-WF Stack Light Monitoring Module

Home | Network | Wi-Fi | I/O Settings | Stack Light | **MQTT** | Filter | Monitor | Change Password | Logout

MQTT is a Client Server publish/subscribe messaging transport protocol. It is light weight, open, simple, and designed so as to be easy to implement. These characteristics make it ideal for use in many situations, including constrained environments such as for communication in Machine to Machine (M2M) and Internet of Things (IoT) contexts where a small code footprint is required and/or network bandwidth is at a premium.

Please note that the MQTT is only available to the Ethernet interface for the SL series modules.

Clicking the **MQTT** tab will display the MQTT settings page allowing you enable and configure the MQTT connections for the SL device, which will be described in more detail below.

### 5.6.1 Connectivity Settings

#### Connectivity Settings

MQTT	Disable ▾
Broker	<input checked="" type="radio"/> IP 192 . 168 . 255 . 10 <input type="radio"/> Host Name <input type="text"/>
Broker Port	1883 (Default= 1883)
Client Identifier	SL-P6R1-WF_640002
Alias Name	EtherIO (Max. 30 chars, part of the topic name)
User Name	<input type="text"/> (Max. 63 chars)
Password	<input type="text"/> (Max. 63 chars)
Reconnection Interval	10 (5 ~ 65535 s, Default= 10)
Keep Alive Interval	20 (5 ~ 65535 s, Default= 20)
<input type="button" value="Update Settings"/>	

The following table provides an overview of the parameters contained in the Connectivity Settings section:

Item	Description	Default Value
MQTT	Disable or enable the MQTT connection function.	Disable
Broker	The MQTT broker can be specified by either IP or host name.	IP: 192.168. 255.10
Broker Port	This port of the MQTT broker.	1883
Client Identifier	The client identifier uniquely identifies the MQTT client to the MQTT broker. It consists of "module name"+ "_" (under line character) + "the last 6 digits of MAC address" and cannot be changed.	
Alias Name	It is part of the MQTT topic and should be different from other MQTT client. Its length should be no more than 30 characters.	EtherIO
User Name	This parameter is used when the MQTT broker requires authentication. Its length should be no more than 12 characters. For firmware version 1.5.0 and later, the maximum length is increased to 63 characters.	
Password	This parameter is used when the MQTT broker requires authentication. Its length should be no more than 12 characters. For firmware version 1.5.0 and later, the maximum length is increased to 63 characters.	
Reconnection Interval	The time interval for that the SL module will retry to connect to the broker if a connection failure occurs. It should be in the range of 5 to 65535 seconds.	10
Keep Alive Interval	The keep-alive mechanism is provided to ensure that both the client and the broker are alive and the connection is still open. If a client doesn't send any messages during the period of the keep alive, it must send a PINGREQ packet to the broker to confirm its availability. And the broker must reply with a PINGRESP packet to indicate its availability. The broker will disconnect a client, which doesn't send PINGREQ or any other message in one and a half time of the keep alive interval. It should be in the range of 5 to 65535 seconds.	20
Update Settings	Click this button to save the revised settings to the SL device.	

## 5.6.2 Last Will Settings

### Last Will Settings

Last Will and Testament	<input type="checkbox"/>
Topic	<input type="text"/> (Max. 30 chars)
Message	<input type="text"/> (Max. 30 chars)
QoS	0 - At most once ▼
Retained	<input type="checkbox"/>
<input type="button" value="Update Settings"/>	

The MQTT Last Will and Testament (LWT) feature is used to notify other clients about an ungracefully disconnected client. A SL module can register an offline message (LWT) to the broker. The LWT message will be delivered to all clients who subscribe to the offline topic if the SL module disconnects unexpectedly.

The following table provides an overview of the parameters contained in the Last Will Settings section:

Item	Description	Default Value
Last Will and Testament	Tick the option to enable the last will and testament function.	Disable
Topic	The topic name of the last will. Its length should be no more than 30 characters.	
Message	The message of the last will. Its length should be no more than 30 characters.	
QoS	The QoS of the last will message.	0 - At most once
Retained	Tick the option so that the will message is to be retained when it is published.	Disable
Update Settings	Click this button to save the revised settings to the SL device.	

## 5.6.3 Publication Settings

### Publication Settings

Cycle	<input type="text" value="1000"/> (400 ~ 65500 ms, in 10 ms step, Default= 1000)
Publication Topic Format	(Module Topic Name)(Sub Topic Name) <input type="button" value="v"/>
Module Topic Name	<input type="text" value="EtherIO/"/> (Max. 255 chars)
Input 0 Sub Topic Name	<input type="text" value="IN0"/> (Max. 63 chars) <input type="button" value="Enable"/> <input type="button" value="v"/>
Input 1 Sub Topic Name	<input type="text" value="IN1"/> (Max. 63 chars) <input type="button" value="Enable"/> <input type="button" value="v"/>
Input 2 Sub Topic Name	<input type="text" value="IN2"/> (Max. 63 chars) <input type="button" value="Enable"/> <input type="button" value="v"/>
Input 3 Sub Topic Name	<input type="text" value="IN3"/> (Max. 63 chars) <input type="button" value="Enable"/> <input type="button" value="v"/>
Input 4 Sub Topic Name	<input type="text" value="IN4"/> (Max. 63 chars) <input type="button" value="Enable"/> <input type="button" value="v"/>
Input 5 Sub Topic Name	<input type="text" value="IN5"/> (Max. 63 chars) <input type="button" value="Enable"/> <input type="button" value="v"/>
Current Combinatorial Status Sub Topic Name	<input type="text" value="IN6"/> (Max. 63 chars) <input type="button" value="Enable"/> <input type="button" value="v"/>
Previous Combinatorial Status Sub Topic Name	<input type="text" value="IN7"/> (Max. 63 chars) <input type="button" value="Enable"/> <input type="button" value="v"/>
Current Combinatorial Status Time Sub Topic Name	<input type="text" value="IN8"/> (Max. 63 chars) <input type="button" value="Enable"/> <input type="button" value="v"/>
Previous Combinatorial Status Time Sub Topic Name	<input type="text" value="IN9"/> (Max. 63 chars) <input type="button" value="Enable"/> <input type="button" value="v"/>
All Information Sub Topic Name	<input type="text" value="Info"/> (Max. 63 chars) <input type="button" value="Disable"/> <input type="button" value="v"/>
<input type="button" value="Update Settings"/>	

The following table provides an overview of the parameters contained in the Publication Settings section.

Item	Description	Default Value
Cycle	The time interval the SL module publishes data periodically. It should be in the range of 400 to 65500 milliseconds and in 10 milliseconds step.	1000
Publication Topic Format	The format of the publication topic can be either (Alias Name)/GetValue/(Sub Topic Name) or (Module Topic Name)(Sub Topic Name). The default format is (Alias Name)/GetValue/(Sub Topic Name).	
Module Topic Name	The module topic name when the topic format (Module Topic Name)(Sub Topic Name) is selected.	EtherIO/
Input 0 Sub Topic Name	The sub-topic name of the publication topic of the input channel 0. Its length should be no more than 63 characters.	IN0
Input 1 Sub Topic Name	The sub-topic name of the publication topic of the input channel 1. Its length should be no more than 63 characters.	IN1
Input 2 Sub Topic Name	The sub-topic name of the publication topic of the input channel 2. Its length should be no more than 63 characters.	IN2

Input 3 Sub Topic Name	The sub-topic name of the publication topic of the input channel 3. Its length should be no more than 63 characters.	IN3
Input 4 Sub Topic Name	The sub-topic name of the publication topic of the input channel 2. Its length should be no more than 63 characters.	IN4
Input 5 Sub Topic Name	The sub-topic name of the publication topic of the input channel 2. Its length should be no more than 63 characters.	IN5
Current Combinatorial Status Sub Topic Name	The sub-topic name of the publication topic of the combinatorial status value. Its length should be no more than 63 characters.	IN6
Previous Combinatorial Status Sub Topic Name	The sub-topic name of the publication topic of the previous combinatorial status value. Its length should be no more than 63 characters.	IN7
Current Combinatorial Status Time Sub Topic Name	The sub-topic name of the publication topic of the duration of the current status. Its length should be no more than 63 characters.	IN8
Previous Combinatorial Status Time Sub Topic Name	The sub-topic name of the publication topic of the duration of the previous status. Its length should be no more than 63 characters.	IN9
All Information Sub Topic Name	The sub-topic name of the publication topic of all information. Its length should be no more than 63 characters. Following is a sample all information topic: <pre>{   "ModuleName":"SL-P6R1-WF",   "MacAddress":"000DE0FFFFFD",   "IN0":"0",   "IN1":"0",   "IN2":"0",   "IN3":"0",   "IN4":"0",   "IN5":"0",   "CurrentValue":"1",   "PreviousValue":"0",   "CurrentTime":"4074",   "PreviousTime":"25",   "AlarmStatus":"Off" }</pre>	Info
Update Settings	Click this button to save the revised settings to the SL device.	

## 5.6.4 Subscription Settings

### Subscription Settings

Subscription Topic Format	<input type="text" value="((Alias Name)/SetValue/(Sub Topic Name)"/>	<input type="button" value="v"/>
DO0 Sub Topic Name	<input type="text" value="DO0"/>	(Max. 63 chars)
<input type="button" value="Update Settings"/>		

The following table provides an overview of the parameters contained in the Subscription Settings section.

Item	Description	Default Value
Subscription Topic Format	The format of the subscription topic can be either (Alias Name)/SetValue/(Sub Topic Name) or (Module Topic Name)(Sub Topic Name). The default format is (Alias Name)/SetValue/(Sub Topic Name).	
DO0 Sub Topic Name	The sub-topic name of the subscription topic of the digital output channel 0. Its length should be no more than 63 characters.	DO0
Update Settings	Click this button to save the revised settings to the SL device.	

## 5.7 Filter



### SL-P6R1-WF Stack Light Monitoring Module

[Home](#) | 
 [Network](#) | 
 [Wi-Fi](#) | 
 [I/O Settings](#) | 
 [Stack Light](#) | 
 [MQTT](#) | 
 **[Filter](#)** | 
 [Monitor](#) | 
 [Change Password](#) | 
 [Logout](#)

Clicking the **Filter** tab will display the **Filter Settings** page allowing you configure the IP Filter list for the SL device, which will be described in more detail below.

### 5.7.1 Filter Settings

The **Filter Settings** page is used to query or edit the IP Filter List for the SL series module. The IP filter list restricts the access of incoming packets based on the IP header. If one or more IP addresses are saved to the IP Filter table, only Clients whose IP address is specified in the IP Filter List will be able to access the SL series module.

**Filter Settings:**

IP Filter List	IP Address
IP1:	0.0.0.0
IP2:	0.0.0.0
IP3:	0.0.0.0
IP4:	0.0.0.0
IP5:	0.0.0.0

Add . . .  To The List  
 Delete IP#   
 Delete ALL  
 Save to Flash

The following table provides an overview of the parameters contained in the IP Address Configuration section:

Item	Description
Add "IP" to the List	This parameter is used to add an IP address to the IP Filter List.
Delete IP # "number"	This parameter is used to delete IP# address from the IP Filter List.
Delete All	This parameter is used to delete all IP address current contained in the IP Filter List.
Save to Flash	This parameter is used to save the updated IP Filter List to the Flash memory. Check the checkbox before clicking the Submit button of you wish to store the most recent list.
Submit	Click this button to save the revised settings to SL device.

## 5.8 Monitor



Clicking the **Monitor** tab will display the **Current Connection Status** page. It lists the IP of the devices which are connected to the SL module.

### Current Connection Status:

Server Mode	Server
Connected IP1:	10.0.11.3
IP2:	0.0.0.0
IP3:	0.0.0.0
IP4:	0.0.0.0
IP5:	0.0.0.0
IP6:	0.0.0.0
Available Connections:	31

## 5.9 Change Password

Clicking the **Change Password** tab will display the **Change Password** page. To change a password, first enter the old password in the **“Current password”** field (default is **Admin**) and then enter a new password in the **“New password”** field. Re-enter the new password in the **“Confirm new password”** field, and then click the **“Submit”** button to update the password.



**Change Password**  
The length of the password is 12 characters maximum.

Current password:	<input type="password" value="••••"/>
New password:	<input type="password" value="••••"/>
Confirm new password:	<input type="password" value="••••"/>
	<input type="submit" value="Submit"/>



## 5.10 Logout

Clicking the **Logout** tab will immediately log you out from the system and return you to the login page.



### SL-P6R1-WF Stack Light Monitoring Module

[Home](#) | [Network](#) | [Wi-Fi](#) | [I/O Settings](#) | [Stack Light](#) | [MQTT](#) | [Filter](#) | [Monitor](#) | [Change Password](#) | **Logout**

**The system is logged out.**

To enter the web configuration, please type password in the following field.

Login password:

When using IE, please disable its cache as follows.

Menu items: Tools / Internet Options... / General / Temporary Internet Files / Settings... / Every visit to the page

## 6. RS-485 Interface

If the SL module is connected through the RS-485 interface, then you can use the DCON Utility Pro to configure and test the module.

### 6.1 Install DCON Utility Pro

ICP DAS provides different versions of DCON Utility Pro for different platforms that can be used to configure and test I/O modules. The installation file locations for different platforms are as follows:

For Windows 98,NT,2000,XP,Vista,Win 7 and Win 8 on PC, laptop and etc computer	
CD	CD:\ 8000\NAPDOS\Driver\DCON_Utility
FTP	<a href="http://ftp.icpdas.com/pub/cd/8000cd/napdos/driver/dcon_utility/">http://ftp.icpdas.com/pub/cd/8000cd/napdos/driver/dcon_utility/</a>
For ICP DAS CE5 platform PAC	
CD	CD:\ napdos\wp-8x4x_ce50\Micro_SD\DCON_Utility_Pro
FTP	<a href="http://ftp.icpdas.com.tw/pub/cd/winpac/napdos/wp-8x4x_ce50/micro_sd/dcon_utility_pro/">http://ftp.icpdas.com.tw/pub/cd/winpac/napdos/wp-8x4x_ce50/micro_sd/dcon_utility_pro/</a>
For ICP DAS CE6 platform PAC	
CD	CD:\ XPAC\XPAC-ATOM-CE6\PC_Tools\DCON_Utility_Pro
FTP	<a href="http://ftp.icpdas.com.tw/pub/cd/xpac-atom-ce6/pc_tools/dcon_utility_pro/">http://ftp.icpdas.com.tw/pub/cd/xpac-atom-ce6/pc_tools/dcon_utility_pro/</a>
For ICP DAS CE7 platform and ARM CPU PAC	
CD	CD:\WinPAC_AM335x\Wp-5231\System_Disk\Tools \DCON_Utility_Pro
FTP	<a href="http://ftp.icpdas.com.tw/pub/cd/winpac_am335x/wp-5231/system_disk/tools/dcon_utility_pro">http://ftp.icpdas.com.tw/pub/cd/winpac_am335x/wp-5231/system_disk/tools/dcon_utility_pro</a>

For ICP DAS WES platform PAC

CD CD:\XPAC\XPAC-Atom\tools\DCON\_Utility\_pro

FTP [http://ftp.icpdas.com.tw/pub/cd/xpac-atom/tools/dcon\\_utility\\_pro/](http://ftp.icpdas.com.tw/pub/cd/xpac-atom/tools/dcon_utility_pro/)

## 6.2 Search and Find the Module

Click on the COM port button to select the correct COM Port and select the baud rates to be searched.

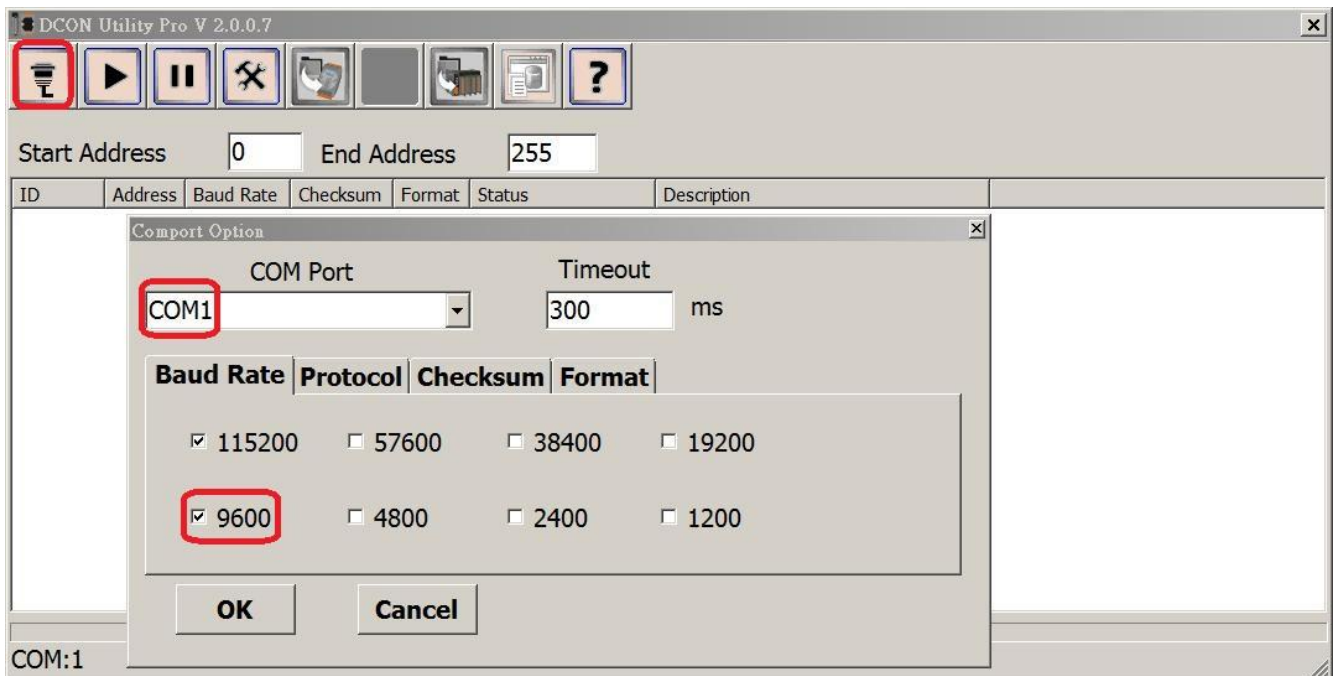

Click on the Protocol tab to select the protocols to be searched.

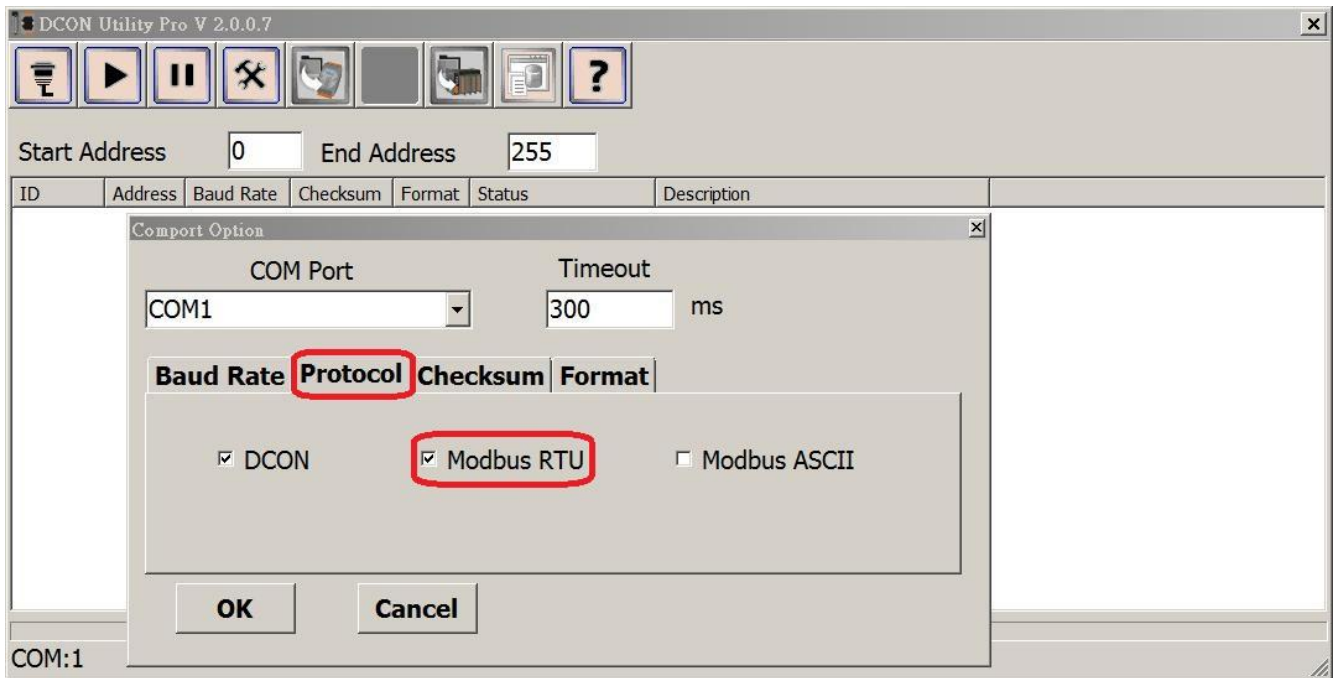

Click on the search button to find the modules on the RS-485 bus.

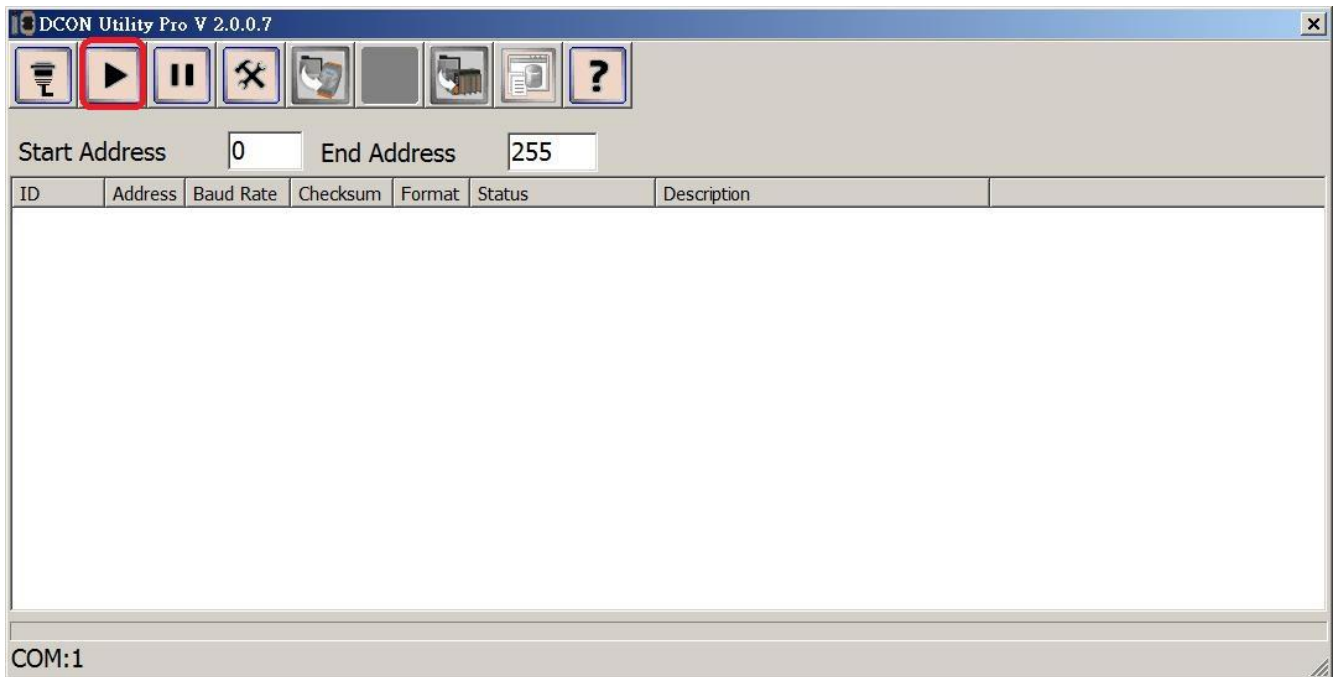

## 6.3 Configure and Test the Module

When the module is found, click on the module name to enter the configuration form.

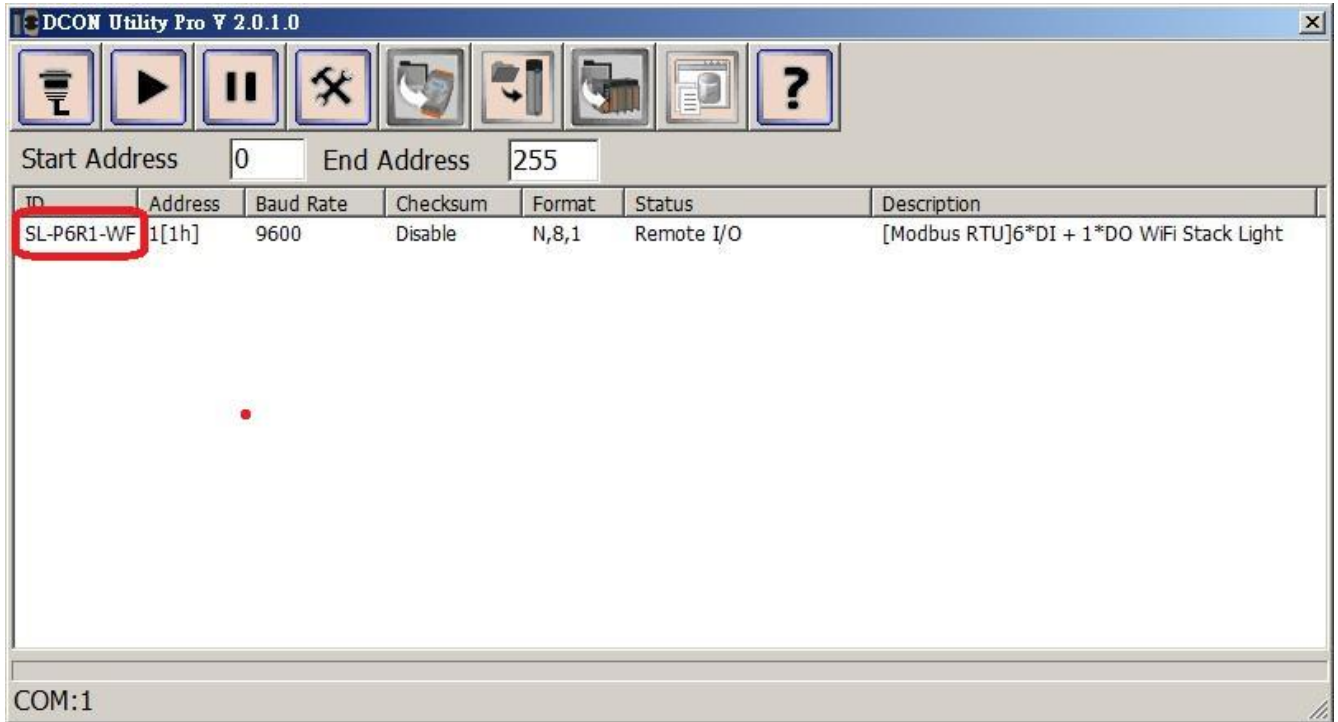

In the configuration form, you can change the address, baud rate, parity and response delay settings. Click on the Set Module Configurations button to save the changes to the module.

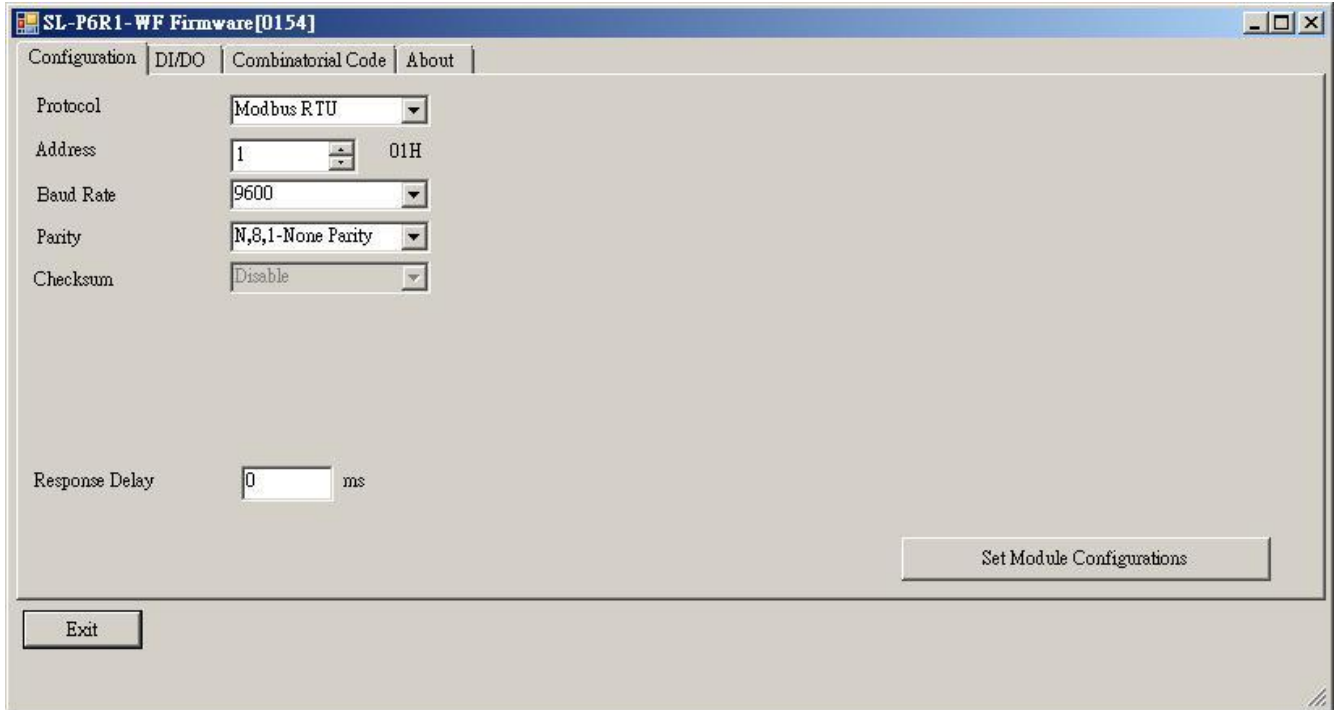

Click on the DI/DO tab, you can turn on/off the digital output and get the status of the stack lights, including the combinatorial status value and the time of the previous state.

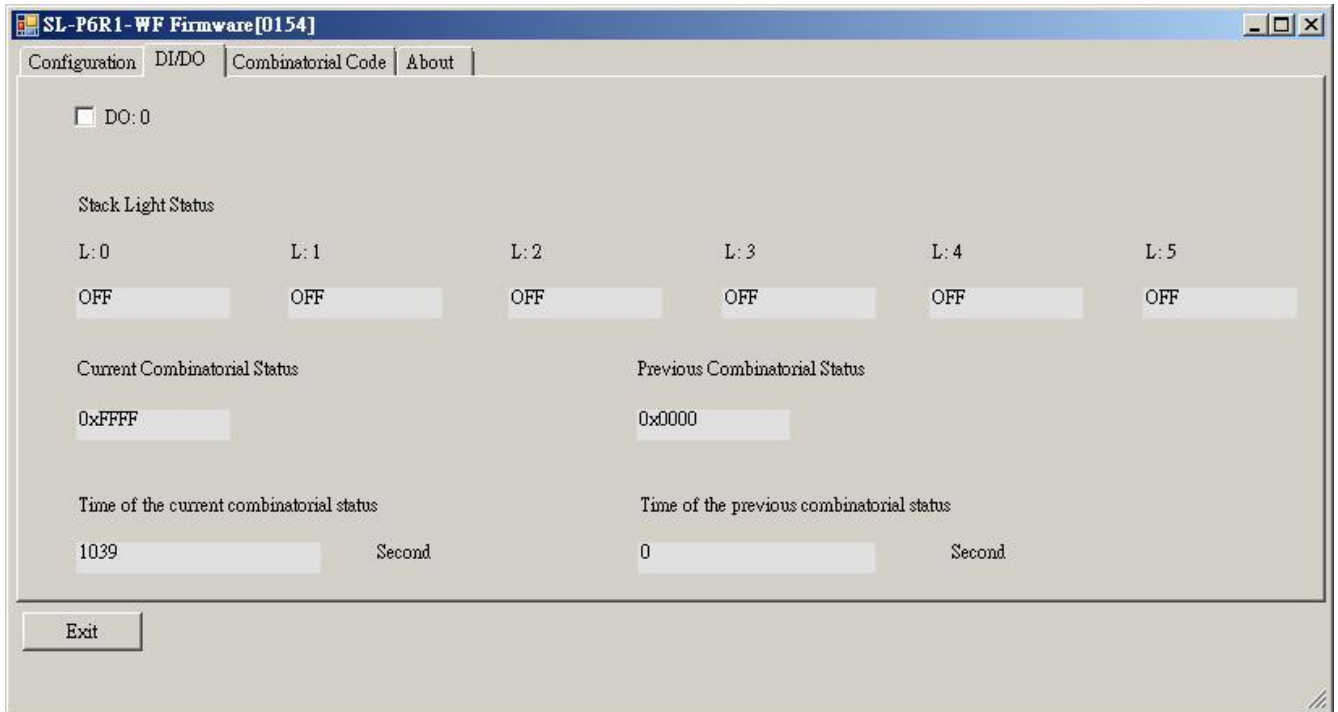

Click on the Combinatorial Code tab, you can change the combinatorial value settings.

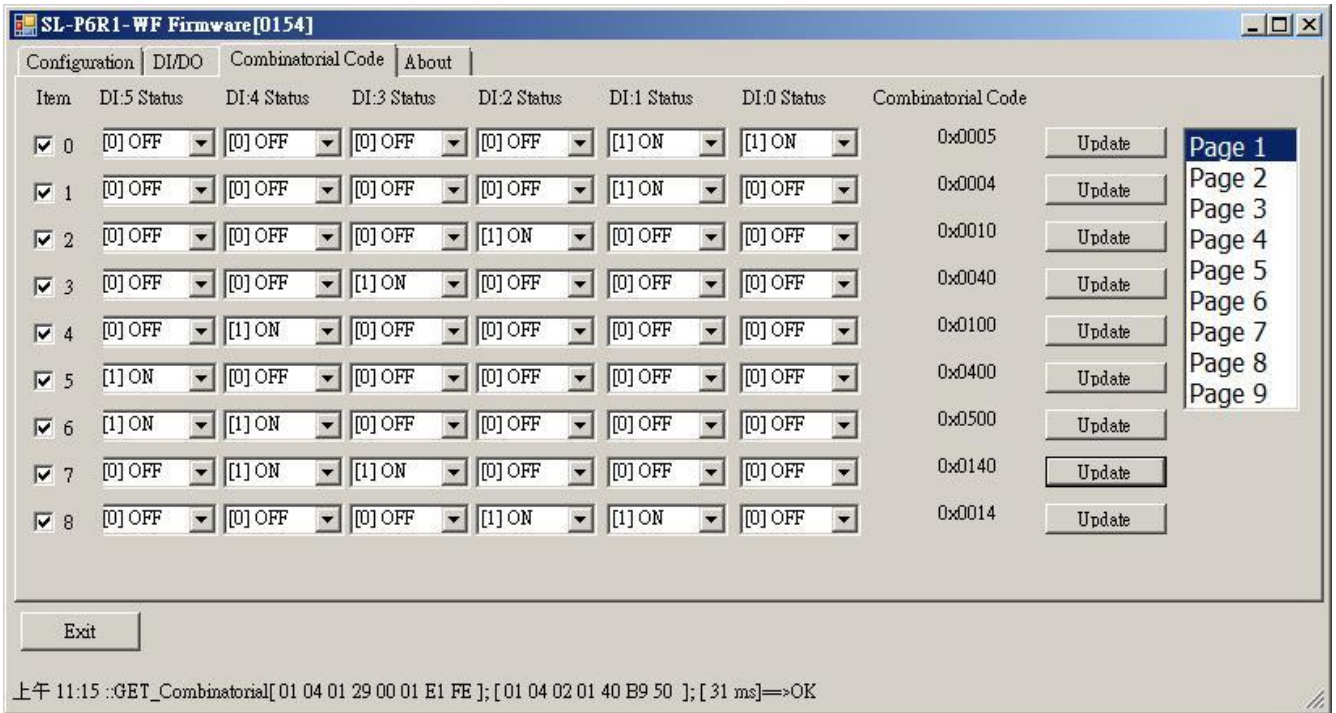



## 7. Modbus Information

The SL series is a family of Modbus I/O devices that allow you to remotely control input/output terminals via an Ethernet, Wi-Fi or RS-485 connection and uses a master-slave communication technique in which only one device (the master) can initiate a transaction (called queries), while other devices (slaves) respond by either supplying the requested data to the master, or by taking the action requested in the query.

Most SCADA (Supervisory Control and Data Acquisition) and HMI software, such as Citect (Schneider Electric), ICONICS, iFIX, InduSoft, Intouch, Entivity Studio, Entivity Live, Entivity VLC, Trace Mode, Wizcon (EUTIONS), and Wonderware, etc. can be used to easily integrate serial devices via the Modbus protocol.

Modbus/TCP and Modbus RTU master applications can also be developed using any programming language, such as VB, C# and so on.

ICP DAS provides the Modbus SDK that allows development of Modbus applications on a PC.

The relevant demo programs and SDK can be obtained from the following locations:

VB Demo : [http://ftp.icpdas.com/pub/cd/6000cd/napdos/et7000/demo/pc\\_client/](http://ftp.icpdas.com/pub/cd/6000cd/napdos/et7000/demo/pc_client/)

.Net demo and SDK : <http://ftp.icpdas.com/pub/cd/8000cd/napdos/modbus/nmodbus/>

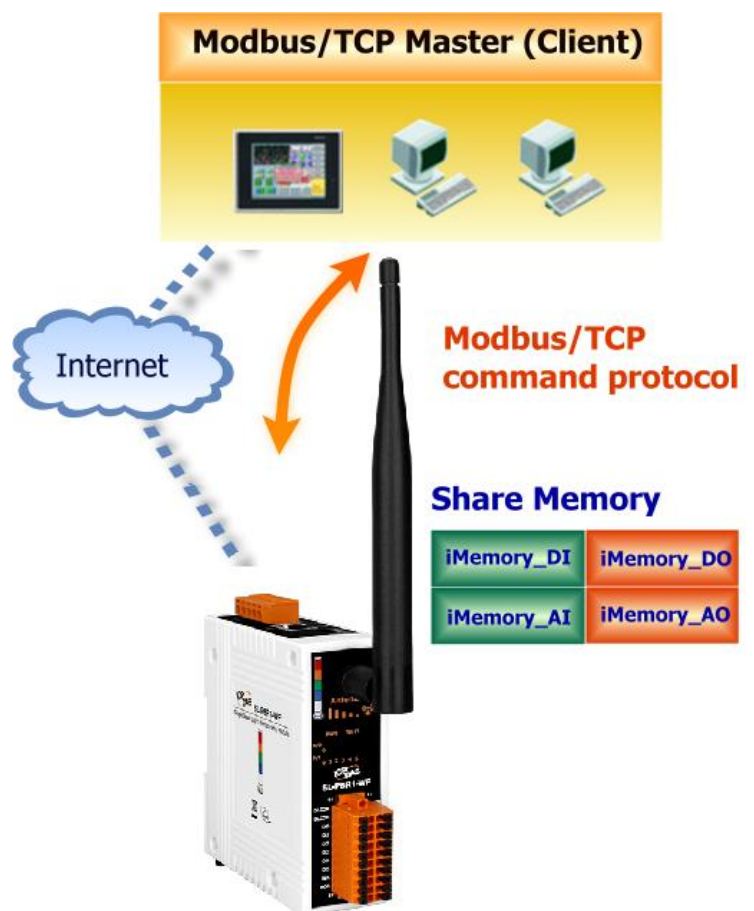

## 7.1 What is Modbus RTU and Modbus TCP/IP?

Modbus is a communication protocol that was developed by Modicon Inc. in 1979, and was originally designed for use with Modicon controllers. Detailed information regarding the Modbus protocol can be found at: <http://www.modbus.org>.

The different versions of the Modbus protocol used today include Modbus RTU, which is based on serial communication interfaces such as RS-485 and RS-232, Modbus ASCII and Modbus TCP, which uses the Modbus RTU protocol embedded into TCP packets.

Modbus TCP is an internet protocol. The protocol embeds a Modbus frame into a TCP frame so that a connection oriented approach is obtained, thereby making it more reliable. The master queries the slave and the slave responds with a reply. The protocol is open and, hence, highly scalable.

## 7.2 Modbus Message Structure

Modbus devices communicate using a master-slave (client-server) technique in which only one device (the master/client) can initiate transactions (called queries). The other devices (slaves/servers) respond by either supplying the requested data to the master, or by taking the action requested in the query.

A query from a master will consist of a slave address (or broadcast address), a function code defining the requested action, any required data, and an error checking field. A response from a slave consists of fields confirming the action taken, any data to be returned, and an error checking field.

### ➤ The Modbus/TCP Message Structure

Bytes 00 - 05	Bytes 06 - 11
6-byte header	Modbus RTU Data

➤ **The Leading 6 bytes of a Modbus/TCP Protocol Query**

Byte 00	Byte 01	Byte 02	Byte 03	Byte 04	Byte 05
Transaction identifier		Protocol identifier		Length Field (upper byte )	Length Field (lower byte)

**Transaction identifier** = Assigned by the Modbus/TCP master (client)

**Protocol identifier** = 0

**Length field (upper byte)** = 0 (since all messages are smaller than 256)

**Length field (lower byte)** = The number of following RTU data bytes

➤ **Modbus RTU Data Structure**

Byte 06	Byte 07	Bytes 08 - 09	Bytes 10 - 11
Net ID (Station Number)	Function Code	Data Field	
		Reference Number (Address Mapping)	Number of Points

1. **Net ID** specifies the address of the receiver (Modbus slave).
2. **Function Code** specifies the message type.
3. **Data Field** is the data block.

## 1. Net ID (Station Number)

The first byte in the frame structure of a Modbus RTU query is the receiver's address. A valid address is in the range of 0 to 247. Address 0 is used for general broadcast, while addresses 1 to 247 are given to individual Modbus devices.

## 2. Function Code

The second byte in the frame structure of a Modbus RTU query is the function code, which describes what the slave device is required to do. Valid function codes are between 1 and 255. To answer the query, the slave device uses the same function code as contained in the request. The highest bit of the function code will only be set to '1' if an error occurs in the system. In this way, the master will know whether the message has been transmitted correctly or not.

Section	Code	Function	Reference (Address)
<a href="#">6.2.1</a>	<b>01 (0x01)</b>	Read the Status of the Coils (Read back DOs)	0xxxx
<a href="#">6.2.2</a>	<b>02 (0x02)</b>	Read the Status of the Input (Reads DIs)	1xxxx
<a href="#">6.2.3</a>	<b>03 (0x03)</b>	Read the Holding Registers (Read back AOs)	4xxxx
<a href="#">6.2.4</a>	<b>04 (0x04)</b>	Read the Input Registers (Reads AIs)	3xxxx
<a href="#">6.2.5</a>	<b>05 (0x05)</b>	Force a Single Coil (Writes DO)	0xxxx
<a href="#">6.2.6</a>	<b>06 (0x06)</b>	Preset a Single Register (Writes AO)	4xxxx
<a href="#">6.2.7</a>	<b>15 (0x0F)</b>	Force Multiple Coils (Writes DOs)	0xxxx
<a href="#">6.2.8</a>	<b>16 (0x10)</b>	Preset Multiple Registers (Writes AOs)	4xxxx

## 1. Data Field

Data are transmitted in 8-, 16- and 32-bit format. The data for 16-bit registers is transmitted in high-byte first format. For example: 0x0A0B ==> 0x0A, 0x0B. The data for 32-bit registers is transmitted as two 16-bit registers, and is low-word first. For example: 0x0A0B0C0D ==> 0x0C, 0x0D, 0x0A, 0x0B.

The data field of messages sent between a master and a slave contains additional information about the action to be taken by the master or any information requested by the slave. If the master does not require this information, the data field can be empty.

Reference (Address)	Description
<b>0xxxx</b>	<p><u><a href="#">Read/Write Discrete Outputs or Coils.</a></u></p> <p>A 0x reference address is used to output device data to a digital output channel.</p>
<b>1xxxx</b>	<p><u><a href="#">Read Discrete Inputs.</a></u></p> <p>The ON/OFF status of a 1x reference address is controlled by the corresponding digital input channel.</p>
<b>3xxxx</b>	<p><u><a href="#">Read Input Registers.</a></u></p> <p>A 3x reference register contains a 16-bit number received from an external source, e.g. an analog signal.</p>
<b>4xxxx</b>	<p><u><a href="#">Read/Write Output or Holding Registers.</a></u></p> <p>A 4x register is used to store 16 bits of numerical data (binary or decimal), or to send the data from the CPU to an output channel.</p>



For more details regarding **Address Mapping (Reference Number)**, refer to [Section 7.3 Modbus Register Table.](#)

## 7.2.1 01 (0x01) Read the Status of the Coils (Read back DOs)

This function code is used to read either the current status of the coils or the current digital output read back value from the SL module.

### [Request]

Byte	Description	Size	Value
00	Net ID (Station Number)	1 Byte	1 to 247
01	Function Code	1 Byte	0x01
02-03	Starting DO Address	2 Bytes	Refer to the Modbus Address Table for the SL series. ( <a href="#">Section 7.3 Modbus Register Table</a> ) Byte 02 = high byte Byte 03 = low byte
04-05	Number of Points (Channels)	2 Bytes	Byte 04 = high byte Byte 05 = low byte

### [Response]

Byte	Description	Size	Value
00	Net ID (Station Number)	1 Byte	1 to 247
01	Function Code	1 Byte	0x01
02	Byte Count	1 Byte	Byte Count of the Response ( $n = (\text{Points}+7)/8$ )
03	Data	n Bytes	n= 1; Byte 03 = data bit 7 to 0 n= 2; Byte 04 = data bit 15 to 8 ..... n= m; Byte m+2 = data bit (8m-1) to 8(m-1)

### [Error Response]

Byte	Description	Size	Value
00	Net ID (Station Number)	1 Byte	1 to 247
01	Function Code	1 Byte	0x81
02	Exception Code	1 Byte	Refer to the Modbus Standard Specifications for more details

## Example: Function 01 (0x01), Read back DOs

	<b>[Leading 6 bytes]</b>	<b>[Request]</b>
<b>Command:</b>	<u>01 02 00 00 00 06</u>	<u>01 01 00 00 00 02</u>
	<b>[Leading 6 bytes]</b>	<b>[Response]</b>
<b>Response:</b>	<u>01 02 00 00 00 04</u>	<u>01 01 01 03</u>
Reads the digital output value		

A description of the command and response is as follows:

<b>Command:</b>	<b>[Leading 6 bytes]</b>	
	<b>Bytes 00-03</b>	01 02 00 00 (Message Number)
	<b>Bytes 04-05</b>	00 06 (Number of bytes remaining in this frame)
	<b>[Request]</b>	
	<b>Byte 00</b>	01 (Net ID)
	<b>Byte 01</b>	01 (Function Code)
	<b>Byte 02-03</b>	00 00 (Starting DO Address)
	<b>Byte 04-05</b>	00 02 (Number of Points)

<b>Response:</b>	<b>[Leading 6 bytes]</b>	
	<b>Bytes 00-03</b>	01 02 00 00 (Message Number)
	<b>Bytes 04-05</b>	00 04 (Number of bytes remaining in this frame)
	<b>[Response]</b>	
	<b>Byte 00</b>	01 (Net ID)
	<b>Byte 01</b>	01 (Function Code)
	<b>Byte 02</b>	01 (Byte Count of the Response)
	<b>Byte 03</b>	03 (Value for DO1 to DO0)

## 7.2.2 02 (0x02) Read the Status of the Input (Read DIs)

This function code is used to read the current digital input value from the SL module.

### [Request]

Byte	Description	Size	Value
00	Net ID (Station Number)	1 Byte	1 to 247
01	Function Code	1 Byte	0x02
02-03	Starting DI Address	2 Bytes	Refer to the Modbus Address Table for the SL series. ( <a href="#">Section 7.3 Modbus Register Table</a> ) Byte 02 = high byte Byte 03 = low byte
04-05	Number of Points (Channels)	2 Bytes	Byte 04 = high byte Byte 05 = low byte

### [Response]

Byte	Description	Size	Value
00	Net ID (Station Number)	1 Byte	1 to 247
01	Function Code	1 Byte	0x02
02	Byte Count	1 Byte	Byte Count of Response ( $n = (\text{Points} + 7) / 8$ )
03	Data	n Bytes	n= 1; Byte 03 = data bit 7 to 0 n= 2; Byte 04 = data bit 15 to 8 ..... n= m; Byte m+2 = data bit (8m-1) to 8(m-1)

### [Error Response]

Byte	Description	Size	Value
00	Net ID (Station Number)	1 Byte	1 to 247
01	Function Code	1 Byte	0x82
02	Exception Code	1 Byte	Refer to the Modbus Standard Specifications for more details



## Example: Function 02 (0x02), Read DIs

	<b>[Leading 6 bytes]</b>	<b>[Request]</b>
<b>Command:</b>	<u>01 02 00 00 00 06</u>	<u>01 02 00 00 00 02</u>
	<b>[Leading 6 bytes]</b>	<b>[Response]</b>
<b>Response:</b>	<u>01 02 00 00 00 04</u>	<u>01 02 01 03</u>
Reads the digital input value		

A description of the command and response is as follows:

<b>Command:</b>	<b>[Leading 6 bytes]</b>	
	<b>Bytes 00-03</b>	01 02 00 00 (Message Number)
	<b>Bytes 04-05</b>	00 06 (Number of bytes remaining in this frame)
	<b>[Request]</b>	
	<b>Byte 00</b>	01 (Net ID)
	<b>Byte 01</b>	02 (Function Code)
	<b>Bytes 02-03</b>	00 00 (Starting DI Address)
	<b>Bytes 04-05</b>	00 02 (Number of Points)

<b>Response:</b>	<b>[Leading 6 bytes]</b>	
	<b>Bytes 00-03</b>	01 02 00 00 (Message Number)
	<b>Bytes 04-05</b>	00 04 (Number of bytes remaining in this frame)
	<b>[Response]</b>	
	<b>Byte 00</b>	01 (Net ID)
	<b>Byte 01</b>	02 (Function Code)
	<b>Byte 02</b>	01 (Byte Count of the Response)
	<b>Byte 03</b>	03 (Value for DI1 to DI0)

## 7.2.3 03 (0x03) Read the Holding Registers (Read back AOs)

This function code is used to read back either the current values in the holding registers or the analog output value from the SL module. These registers are also used to store the preset values for the digital counter, the host watchdog timer, the module name and the TCP timeout, etc.

### [Request]

Byte	Description	Size	Value
00	Net ID (Station Number)	1 Byte	1 to 247
01	Function Code	1 Byte	0x03
02-03	Starting AO Address	2 Bytes	Refer to the Modbus Address Table for the SL series . ( <a href="#">Section 7.3 Modbus Register Table</a> ) Byte 02 = high byte Byte 03 = low byte
04-05	Number of 16-bit Registers (Channels)	2 Bytes	Word Count Byte 04 = high byte Byte 05 = low byte

### [Response]

Byte	Description	Size	Value
00	Net ID (Station Number)	1 Byte	1 to 247
01	Function Code	1 Byte	0x03
02	Byte Count	1 Byte	Byte Count of the Response (n=Points x 2 Bytes)
03~	Register Values	n Bytes	Register Values n= 2; Byte 03 = high byte Byte 04 = low byte ..... n= m; Byte 03 = high byte Byte 04 = low byte ..... Byte m+1 = high byte Byte m+2 = low byte

### [Error Response]

Byte	Description	Size	Value
00	Net ID (Station Number)	1 Byte	1 to 247
01	Function Code	1 Byte	0x83
02	Exception Code	1 Byte	Refer to the Modbus Standard Specifications for more details

## Example: Function 03 (0x03), Read AOs

	[Leading 6 bytes]	[Request]
<b>Command:</b>	<u>01 02 00 00 00 06</u>	<u>01 03 01 03 00 02</u>
	[Leading 6 bytes]	[Response]
<b>Response:</b>	<u>01 02 00 00 00 07</u>	<u>01 03 04 50 32 41 32</u>

Reads the name of the module for the tPET-P2A2

A description of the command and response is as follows:

<b>Command:</b>	[Leading 6 bytes]	
<b>Bytes 00-03</b>		01 02 00 00 (Message Number)
<b>Bytes 04-05</b>		00 06 (Number of bytes remaining in this frame)
	[Request]	
<b>Byte 00</b>		01 (Net ID)
<b>Byte 01</b>		03 (Function Code)
<b>Bytes 02-03</b>		01 03 (Starting AO Address)
<b>Bytes 04-05</b>		00 02 (Number of Points)

<b>Response:</b>	[Leading 6 bytes]	
<b>Bytes 00-03</b>		01 02 00 00 (Message Number)
<b>Bytes 04-05</b>		00 07 (Number of bytes remaining in this frame)
	[Response]	
<b>Byte 00</b>		01 (Net ID)
<b>Byte 01</b>		03 (Function Code)
<b>Byte 02</b>		04 (Byte Count of the Response)
<b>Bytes 03-04</b>		50 32 (The low word for the module name: The ASCII code "0x50, 0x32" represents the characters "P" and "2")
<b>Byte 05-06</b>		41 32 (The high word for the module name: The ASCII code "0x41, 0x32" represents the characters "A" and "2")

## 7.2.4 04 (0x04) Read the Input Registers (Read AIs)

This function code is used to read either the input registers or the current analog input value from the SL module.

These registers are also used to store the current value for the digital counter, the number of DI channels and the number of DO channels, etc.

### [Request]

Byte	Description	Size	Value
00	Net ID (Station Number)	1 Byte	1 to 247
01	Function Code	1 Byte	0x04
02-03	Starting AI Address	2 Bytes	Refer to the Modbus Address Table for the SL series. ( <a href="#">Section 7.3 Modbus Register Table</a> ) Byte 02 = high byte Byte 03 = low byte
04-05	Number of 16-bit Registers (Channels)	2 Bytes	Word Count Byte 04 = high byte Byte 05 = low byte

### [Response]

Byte	Description	Size	Value
00	Net ID (Station Number)	1 Byte	1 to 247
01	Function Code	1 Byte	0x04
02	Byte Count	1 Byte	Byte Count of the Response (n=Points x 2 Bytes)
03~	Register Values	n Bytes	Register Values n= 2; Byte 03 = high byte Byte 04 = low byte ..... n= m; Byte 03 = high byte Byte 04 = low byte ..... Byte m+1 = high byte Byte m+2 = low byte

### [Error Response]

Byte	Description	Size	Value
00	Net ID (Station Number)	1 Byte	1 to 247
01	Function Code	1 Byte	0x84
02	Exception Code	1 Byte	Refer to the Modbus Standard Specifications for more details.

## Example: Function 04 (0x04), Read AIs

	<b>[Leading 6 bytes]</b>	<b>[Request]</b>
<b>Command:</b>	<u>01 02 00 00 00 06</u>	<u>01 04 00 64 00 01</u>
	<b>[Leading 6 bytes]</b>	<b>[Response]</b>
<b>Response:</b>	<u>01 02 00 00 00 05</u>	<u>01 04 02 00 06</u>

Reads the number of the DI channels on the SL-P6R1-WF

A description of the command and response is as follows:

<b>Command:</b>	<b>[Leading 6 bytes]</b>	
	<b>Bytes 00-03</b>	01 02 00 00 (Message Number)
	<b>Bytes 04-05</b>	00 06 (Number of bytes remaining in this frame)
	<b>[Request]</b>	
	<b>Byte 00</b>	01 (Net ID)
	<b>Byte 01</b>	04 (Function Code)
	<b>Bytes 02-03</b>	00 64 (Starting AI Address)
	<b>Bytes 04-05</b>	00 01 (Number of 16-bit Registers)

<b>Response:</b>	<b>[Leading 6 bytes]</b>	
	<b>Bytes 00-03</b>	01 02 00 00 (Message Number)
	<b>Bytes 04-05</b>	00 05 (Number of bytes remaining in this frame)
	<b>[Response]</b>	
	<b>Byte 00</b>	01 (Net ID)
	<b>Byte 01</b>	04 (Function Code)
	<b>Byte 02</b>	02 (Byte Count of the Response)
	<b>Bytes 03-04</b>	00 06 (Number of DI Channels on the SL-P6R1-WF)

## 7.2.5 05 (0x05) Force a Single Coil (Write DO)

This function code is used to set the status of a single coil or a single digital output value for the SL module.

### [Request]

Byte	Description	Size	Value
00	Net ID (Station Number)	1 Byte	1 to 247
01	Function Code	1 Byte	0x05
02-03	DO Address	2 Bytes	Refer to the Modbus Address Table for the SL series. ( <a href="#">Section 7.3 Modbus Register Table</a> ) Byte 02 = high byte Byte 03 = low byte
04-05	Output Value	2 Bytes	0xFF 00 sets the output to ON. 0x00 00 sets the output to OFF. All other values are invalid and will not affect the coil. Byte 04 = high byte Byte 05 = low byte

### [Response]

Byte	Description	Size	Value
00	Net ID (Station Number)	1 Byte	1 to 247
01	Function Code	1 Byte	0x05
02-03	DO Address	2 Bytes	The value is the same as Bytes 02-03 of the Request
04-05	Output Value	2 Bytes	The value is the same as Bytes 04-05 of the Request

### [Error Response]

Byte	Description	Size	Value
00	Net ID (Station Number)	1 Byte	1 to 247
01	Function Code	1 Byte	0x85
02	Exception Code	1 Byte	Refer to the Modbus Standard Specifications for more details.

## Example: Function 05 (0x05), Write DO

	<b>[Leading 6 bytes]</b>	<b>[Request]</b>
<b>Command:</b>	<u>01 02 00 00 00 06</u>	<u>01 05 00 01 FF 00</u>
	<b>[Leading 6 bytes]</b>	<b>[Response]</b>
<b>Response:</b>	<u>01 02 00 00 00 06</u>	<u>01 05 00 01 FF 00</u>

Sets Channel DO1 to ON

A description of the command and response is as follows:

<b>Command:</b>	<b>[Leading 6 bytes]</b>	
	<b>Bytes 00-03</b>	01 02 00 00 (Message Number)
	<b>Bytes 04-05</b>	00 06 (Number of bytes remaining in this frame)
	<b>[Request]</b>	
	<b>Byte 00</b>	01 (Net ID)
	<b>Byte 01</b>	05 (Function Code)
	<b>Bytes 02-03</b>	00 01 (DO Address)
	<b>Bytes 04-05</b>	FF 00 (Sets the output to ON)

<b>Response:</b>	<b>[Leading 6 bytes]</b>	
	<b>Bytes 00-03</b>	01 02 00 00 (Message number)
	<b>Bytes 04-05</b>	00 06 (Number of bytes remaining in this frame)
	<b>[Response]</b>	
	<b>Byte 00</b>	01 (Net ID)
	<b>Byte 01</b>	05 (Function Code)
	<b>Bytes 02-03</b>	00 01 (DO Address)
	<b>Bytes 04-05</b>	FF 00 (Indicates that the DO has been set to ON)

## 7.2.6 06 (0x06) Preset a Single Register (Write AO)

This function code is used to set a specific holding register to store the configuration values for the SL module.

### [Request]

Byte	Description	Size	Value
00	Net ID (Station Number)	1 Byte	1 to 247
01	Function Code	1 Byte	0x06
02-03	AO Address	2 Bytes	Refer to the Modbus Address Table for the SL series. ( <a href="#">Section 7.3 Modbus Register Table</a> ) Byte 02 = high byte Byte 03 = low byte
04-05	Register Value	2 Bytes	Register Value Byte 04 = high byte Byte 05 = low byte

### [Response]

Byte	Description	Size	Value
00	Net ID (Station Number)	1 Byte	1 to 247
01	Function Code	1 Byte	0x06
02-03	AO Address	2 Bytes	The value is the same as Bytes 02-03 of the Request
04-05	Register Value	2 Bytes	The value is the same as Bytes 04-05 of the Request

### [Error Response]

Byte	Description	Size	Value
00	Net ID (Station Number)	1 Byte	1 to 247
01	Function Code	1 Byte	0x86
02	Exception Code	1 Byte	Refer to the Modbus Standard Specifications for more details.



### Example: Function 06 (0x06), Write AO

	[Leading 6 bytes]	[Request]
<b>Command:</b>	<u>01 02 00 00 00 06</u>	<u>01 06 01 08 00 3C</u>
	[Leading 6 bytes]	[Response]
<b>Response:</b>	<u>01 02 00 00 00 06</u>	<u>01 06 01 08 00 3C</u>

Sets the system timeout to 60 seconds

A description of the command and response is as follows:

<b>Command:</b>	[Leading 6 bytes]	
<b>Bytes 00-03</b>		01 02 00 00 (Message Number)
<b>Bytes 04-05</b>		00 06 (Number of bytes remaining in this frame)
	[Request]	
<b>Byte 00</b>		01 (Net ID)
<b>Byte 01</b>		06 (Function Code)
<b>Bytes 02-03</b>		01 08 (AO Address)
<b>Bytes 04-05</b>		00 3C (Sets the system timeout to 60 seconds)

<b>Response:</b>	[Leading 6 bytes]	
<b>Bytes 00-03</b>		01 02 00 00 (Message Number)
<b>Bytes 04-05</b>		00 06 (Number of bytes remaining in this frame)
	[Response]	
<b>Byte 00</b>		01 (Net ID)
<b>Byte 01</b>		06 (Function Code)
<b>Bytes 02-03</b>		01 08 (AO Address)
<b>Bytes 04-05</b>		00 3C (Indicates that the system timeout has been set to 60 seconds)

## 7.2.7 15 (0x0F) Force Multiple Coils (Write DOs)

This function code is used to set multiple coils status or write multiple digital output values for the SL module.

### [Request]

Byte	Description	Size	Value
00	Net ID (Station Number)	1 Byte	1 to 247
01	Function Code	1 Byte	0x0F
02-03	Starting DO Address	2 Bytes	Refer to the Modbus Address Table for SL series. ( <a href="#">Section 7.3 Modbus Register Table</a> ) Byte 02 = high byte Byte 03 = low byte
04-05	Number of Output Channels (Points)	2 Bytes	Byte 04 = high byte Byte 05 = low byte
06	Byte count	1 Byte	$n = (\text{Points} + 7) / 8$
07	Output value	n Bytes	A bit corresponds to a channel. A value of 1 for a bit denotes that the channel is ON, while a value of 0 denotes that the channel is OFF. n= 1; Byte 07 = data bit 7 to 0 n= 2; Byte 08 = data bit 15 to 8 ..... n= m; Byte m+6 = data bit (8m-1)to 8 (m-1)

### [Response]

Byte	Description	Size	Value
00	Net ID (Station Number)	1 Byte	1 to 247
01	Function Code	1 Byte	0x0F
02-03	Starting DO Address	2 Bytes	The value is the same as Bytes 02-03 of the Request
04-05	Number of Output Channels (Points)	2 Bytes	The value is the same as Bytes 04-05 of the Request

### [Error Response]

Byte	Description	Size	Value
00	Net ID (Station Number)	1 Byte	1 to 247
01	Function Code	1 Byte	0x8F
02	Exception Code	1 Byte	Refer to the Modbus Standard Specifications for more details.

## Example: Function 15 (0x0F), Write DOs

	<b>[Leading 6 bytes]</b>	<b>[Request]</b>
<b>Command:</b>	<u>01 02 00 00 00 08</u>	<u>01 0F 00 C0 00 01 01 01</u>
	<b>[Leading 6 bytes]</b>	<b>[Response]</b>
<b>Response:</b>	<u>01 02 00 00 00 06</u>	<u>01 0F 00 C0 00 01</u>

Sets the safe value (DO0 – DO1)

A description of the command and response is as follows:

<b>Command:</b>	<b>[Leading 6 bytes]</b>	
	<b>Bytes 00-03</b>	01 02 00 00 (Message Number)
	<b>Bytes 04-05</b>	00 08 (Number of bytes remaining in this frame)
	<b>[Request]</b>	
	<b>Byte 00</b>	01 (Net ID)
	<b>Byte 01</b>	0F (Function Code)
	<b>Bytes 02-03</b>	00 C0 (Starting DO Address)
	<b>Bytes 04-05</b>	00 01 (Number of Output Channels)
	<b>Byte 06</b>	01 (Byte Count)
	<b>Byte 07</b>	01 (Output Value)

<b>Response:</b>	<b>[Leading 6 bytes]</b>	
	<b>Bytes 00-03</b>	01 02 00 00 (Message Number)
	<b>Bytes 04-05</b>	00 06 (Number of bytes remaining in this frame)
	<b>[Response]</b>	
	<b>Byte 00</b>	01 (Net ID)
	<b>Byte 01</b>	0F (Function Code)
	<b>Bytes 02-03</b>	00 C0 (Starting DO Address)
	<b>Bytes 04-05</b>	00 01 (Number of Input Channels)

## 7.2.8 16 (0x10) Preset Multiple Registers (Write AOs)

This function code is used to set multiple holding registers that are used to store the configuration values for the SL module.

### [Request]

Byte	Description	Size	Value
00	Net ID (Station Number)	1 Byte	1 to 247
01	Function Code	1 Byte	0x10
02-03	Starting AO Address	2 Bytes	Refer to the Modbus Address Table for the SL series.. ( <a href="#">Section 7.3 Modbus Register Table</a> ) Byte 02 = high byte Byte 03 = low byte
04-05	Number of 16-bit Registers (Channels)	2 Bytes	Word Count. Byte 04 = high byte Byte 05 = low byte
06	Byte Count	1 Byte	n =Points x 2 Bytes
07	Register Values	n Bytes	Register Values. n= 2; Byte 03 = high byte Byte 04 = low byte ..... n= m; Byte 03 = high byte Byte 04 = low byte ..... Byte m+1 = high byte Byte m+2 = low byte

### [Response]

Byte	Description	Size	Value
00	Net ID (Station Number)	1 Byte	1 to 247
01	Function Code	1 Byte	0x10
02-03	Starting AO Address	2 Bytes	The value is the same as Bytes 02-03 of the Request
04-05	Number of 16-bit Registers (Channels)	2 Bytes	The value is the same as Bytes 04-05 of the Request

### [Error Response]

Byte	Description	Size	Value
00	Net ID (Station Number)	1 Byte	1 to 247
01	Function Code	1 Byte	0x90
02	Exception Code	1 Byte	Refer to the Modbus Standard Specifications for more details.

## Example: Function 16 (0x10), Write AOs

	<b>[Leading 6 bytes]</b>	<b>[Request]</b>
<b>Command:</b>	<u>01 02 00 00 00 0B</u>	<u>01 10 00 32 00 01 02 03 E8 00 00</u>
	<b>[Leading 6 bytes]</b>	<b>[Response]</b>
<b>Response:</b>	<u>01 02 00 00 00 06</u>	<u>01 10 00 32 00 01</u>

Sets the Preset value for the digital counter

A description of the command and response is as follows:

<b>Command:</b>	<b>[Leading 6 bytes]</b>	
	<b>Bytes 00-03</b>	01 02 00 00 (Message Number)
	<b>Bytes 04-05</b>	00 0B (Number of bytes remaining in this frame)
	<b>[Request]</b>	
	<b>Byte 00</b>	01 (Net ID)
	<b>Byte 01</b>	10 (Function Code)
	<b>Bytes 02-03</b>	00 32 (Starting AO Address)
	<b>Bytes 04-05</b>	00 01 (Number of 16-bit Registers)
	<b>Byte 06</b>	02 (Byte Count)
	<b>Bytes 07-10</b>	03 E8 00 00 (Preset Value for the digital counter)

<b>Response:</b>	<b>[Leading 6 bytes]</b>	
	<b>Bytes 00-03</b>	01 02 00 00 (Message Number)
	<b>Bytes 04-05</b>	00 06 (Number of bytes remaining in this frame)
	<b>[Response]</b>	
	<b>Byte 00</b>	01 (Net ID)
	<b>Byte 01</b>	10 (Function Code)
	<b>Bytes 02-03</b>	00 32 (Starting AO address)
	<b>Bytes 04-05</b>	00 01 (Word Count)

## 7.3 Modbus Register Table

Data from 16-bit registers is transmitted in high-byte first order. For example: 0x0A0B ==> 0x0A, 0x0B.  
Data from 32-bit registers is transmitted as two 16-bit registers, and is in low-word first order. For example: 0x0A0B0C0D ==> 0x0C, 0x0D, 0x0A, 0x0B.

### 7.3.1 Common Functions

#### ■ 0xxxx: DO Address (Base 0)

Starting Address	Points	Description	Bits per Point	Range	Access Type
127 (0x7F)	1	Restores all default settings. Only for Modbus TCP protocol.	1	1 = Restore	W (Pulse)
128 (0x80)	1	Default ID Settings. Only for Modbus TCP protocol.	1	1 = Restore	W (Pulse)
133 (0x85)	1	Reboots the SL module. Only for Modbus TCP protocol.	1	1 = Reboot	W (Pulse)
256 (0x100)	1	1 to indicate Modbus RTU protocol. Only for Modbus RTU protocol	1	1	R
259 (0x103)	1	Modbus RTU host watchdog mode 0: same as I-7000 1: can use AO and DO command to clear host watchdog timeout status Only for Modbus RTU protocol	1	0, 1	R/W/F
260 (0x104)	1	RS-485 host watchdog mode, 1: enable, 0: disable. Only for Modbus RTU protocol	1	0, 1	R/W/F
269 (0x10D)	1	Host watch dog timeout status, write 1 to clear host watch dog timeout status Only for Modbus RTU protocol	1	0, 1	R/W

272 (0x110)	1	Reset status, 1: first read after powered on, 0: not the first read after powered on Only for Modbus RTU protocol	1	0, 1	R
Notes	<p>“R”: Read;                  “W”: Write;                  “F”: Setting is recorded in flash as default.  <b>Warning:</b> Frequent writing to the Flash can cause it to become corrupt.</p>				

■ **3xxxx: AI address (Base 0)**

Starting Address	Points	Description	Bits per Point	Range	Access Type
151 (0x97)	1	Firmware Version , Only for Modbus TCP protocol.	16	“123” denotes that the version is 1.2.3	R
480 (0x1E0)	2	Firmware version. Only for Modbus RTU protocol.	32		R
482 (0x1E2)	2	Module name. Only for Modbus RTU protocol.	32		R
Notes	“R”: Read				

#### ■ 4xxxx: AO Address (Base 0)

Starting Address	Points	Description	Bits per Point	Range	Access Type
257 (0x101)	1	Sets the Host Watchdog Timer (WDT). Only for Modbus TCP protocol.	16	<b>&lt;5:</b> Disabled <b>5 to 65535:</b> Enabled (units: seconds) <b>0:</b> Default  If the SL module loses communication with the host PC for more than the period defined in the WDT settings, the DO channels will revert to their safe values and the Host WDT Events Counter will be increased by one.	R/W/F
258 (0x102)	1	Host WDT Events. Only for Modbus TCP protocol.	16	Denotes how many Host WDT Events have occurred since the last CPU reset	R/W
259 (0x103)	1	Module Name. Only for Modbus TCP protocol.	16	Module Name	R
263 (0x107)	1	Sets the TCP Timeout Value. Only for Modbus TCP protocol.	16	<b>&lt;5:</b> Disabled <b>5 to 65535:</b> Enabled (units: seconds) <b>0:</b> Default	R/W/F
264 (0x108)	1	Sets the System Timeout Value. Only for Modbus TCP protocol.	16	<b>&lt;30:</b> Disabled <b>30~65535:</b> Enabled (unit: second) <b>0:</b> default	R/W/F
484 (0x1E4)	1	RS-485 module address, 1 to 247. Only for Modbus RTU protocol	16	<b>1 to 247</b>	R/W/F



485 (0x1E5)	1	RS-485 baud rate and parity settings Bits 5:0 Baud rate, valid range: 3 ~ 10 Bits 7:6 00: no parity, 1 stop bit 01: no parity, 2 stop bit 10: even parity, 1 stop bit 11: odd parity, 1 stop bit Only for Modbus RTU protocol	16	6:Default	R/W/F
487 (0x1E7)	1	RS-485 response delay time in milliseconds. Only for Modbus RTU protocol	16	<b>0 to30</b> (units: milliseconds) <b>0:</b> Default	R/W/F
488 (0x1E8)	1	RS-485 host watchdog timeout value, 0 ~ 255, in 0.1s. Only for Modbus RTU protocol	16	<b>0~255</b> (unit: 0.1second) <b>255:</b> default	R/W/F
491 (0x1EB)	1	RS-485 host watchdog timeout count, write 0 to clear. Only for Modbus RTU protocol	16	<b>0</b>	R/W
Notes	<p><b>“R”</b>: Read;  <b>“W”</b>: Write;  <b>“F”</b>: Setting is recorded in flash as default.  <b>Warning:</b> Frequent writing to the Flash can cause it to become corrupt.</p>				

## 7.3.2 Specific Functions

The nDI and nDO parameters for each SL series module used in the following Modbus Address Tables are as follows:

Model Name	Number of DO Channels (nDO)	Number of DI Channels (nDI)
SL-P6R1-WF	1	6
SL-PA6R1-WF	1	6

### ■ 0xxxx: DO address (Base 0)

Starting Address	Points	Description	Bits per Point	Range	Access Type
0 (0x00)	1 to nDO	Digital Output Channels	1	0 = Off 1 = On	R/W
160 (0xA0)	1 to nDO	Sets the Power-on value for all DO Channels	1	0 = Off 1 = On (Default= 0)	R/W/F
192 (0xC0)	1 to 1DO	Sets the Safe value for all DO Channels	1	0 = Off 1 = On (Default= 0)	R/W/F
Notes	"R": Read "W": Write "F": Settings are recorded in flash by default <b>Warning:</b> Frequency writing to the Flash can cause it to become corrupt.				

### ■ 1xxxx: DI address (Base 0)

Starting Address	Points	Description	Bits per Point	Range	Access Type
16 (0x10)	1 to nDI	The status of all Digital Input Channels	1	0 = Off 1 = On	R
Notes	"R": Read				

### ■ 3xxxx: AI Address (Base 0)

Starting Address	Points	Description	Bits per Point	Value	Access Type
0 (0x0)	6	Status of the monitored stack light of channel 0 to 3, 0 for off, 1 for on, and 2 for flashing	16	0 to 2	R
6 (0x6)	1	Current combinatorial status of the monitored stack lights. For details regarding combinatorial status, please refer to 5.5.2 Combinatorial Table Settings.	16	0 to 65535	R
7 (0x7)	1	Previous combinatorial status of the monitored stack lights.	16	0 to 65535	R
8 (0x8)	1	Low word of the time of the current combinatorial status of the monitored stack lights in seconds.	16	0 to 65535	R
9 (0x9)	1	High word of the time of the current combinatorial status of the monitored stack lights in seconds.	16	0 to 65535	R
10 (0xA)	1	Low word of the time of the previous combinatorial status of the monitored stack lights in seconds	16	0 to 65535	R
11 (0xB)	1	High word of the time of the previous combinatorial status of the monitored stack lights in seconds	16	0 to 65535	R
100 (0x64)	1	Number of DI Channels	16	nDI	R
110 (0x6E)	1	Number of DO Channels	16	nDO	R
Notes	"R": Read				

#### ■ 4xxxx: AO Address (Base 0)

Starting Address	Points	Description	Bits per Point	Range	Access Type
201 (0xC9)	1	Digital filter time in millisecond. Only available to SL-P6R1-WF.	16	0 to 6500	R/W/F
288 (0x120)	1	This parameter is used to set the interval period in millisecond to check whether there is an on/off change in the input channel during the period. It should be multiple of 10ms.	16	0 to 65530	R/W/F
289 (0x121)	1	This parameter is used to set the number of checking interval parameter, N. If there is no on/off change in the recent N/2 checking intervals, then the state of the input channel is set to on or off state. Otherwise, if there are on/off change happened in four or more of the recent N checking intervals, then the state of the input channel is set to blinking.	16	1 to 65535	R/W/F
290 (0x122)	81	Table to convert to combinatorial status value 0 to 80. Each register is consisted of 4 nibbles in the form 0xDCBA, where A is the status of the stack light 0 and B is the status of the stack light 1, etc. 0xFFFF for not used. For details regarding combinatorial status value, please refer to 5.5.2 Combinatorial Table Settings.	16	0 to 65535	R/W/F

641 (0x281)	1	This parameter is used to specify the Wi-Fi mode of the SL device. It can be 0 for station mode or 2 for AP mode. For AP mode, only one device can be connected.	16	0, 2	R/W/F
642 (0x282)	1	This parameter is used to specify which security protocol is used to secure wireless computer network. It can be 0 for open, 1 for WEP, or 2 for WPA/WPA2. It is recommended to use WPA/WPA2 if possible.	16	0 to 2	R/W/F
643 (0x283)	7	WEP password Byte 0: password length Byte 1 ~ 13: password	16		R/W/F
650 (0x28A)	32	WPA/WPA2 password Byte 0: password length Byte 1 ~ 63: password	16		R/W/F
682 (0x2AA)	1	This parameter is used to specify whether to turn on the DHCP server function. It can be 0 for turning off and 1 for turning on. It is only available to the AP mode.	16	0, 1	R/W/F
683 (0x2AB)	2	This parameter is used to specify the start IP address of the allocated IP by the DHCP server when the DHCP server function is turned on. It is only available to the AP mode.	16	0 to 65535	R/W/F

686 (0x2AE)	1	IP address type in station mode, 0 for static type, 1 for DHCP This parameter is only available to the station mode and it can be 0 for Static IP or 1for DHCP. If DHCP is supported by the AP you would like to connect, then DHCP should be selected. Otherwise, select Static IP and the following three parameters IP Address, Subnet Mask and Gateway should be set, too.	16	0, 1	R/W/F
687 (0x2AF)	2	Each SL device connected to the Wi-Fi network must have its own unique IP address. This parameter is used to assign a specific IP address.	16	0 to 65535	R/W/F
689 (0x2B1)	2	This parameter is used to assign the subnet mask for the SL device. The subnet mask indicates which portion of the IP address is used to identify the local network or subnet.	16	0 to 65535	R/W/F
691 (0x2B3)	2	This parameter is used to assign the IP address of the gateway to be used by the SL device. A gateway (or router) is a device that is used to connect an individual network to one or more additional networks.	16	0 to 65535	R/W/F
693 (0x2B5)	16	This parameter is used to specify the Service Set Identifier, SSID. For station mode, specify the SSID of the AP you would like to connect. For AP mode, the SSID will be used by the device to be connected.	16		R/W/F
709 (0x2C5)	1	This parameter is used to specify which channel is used for Wi-Fi transmission. It can be 1 to 11. It is only available to the AP mode.	16	1 to 11	R/W/F

710 (0x2C6)	1	This parameter is used to set the local port of the Wi-Fi interface to be used by the Modbus slave device. The default value is 502.	16	00 to 65535	R/W/F
714 (0x2CA)	1	Write 1 to let the new Wi-Fi settings take effect	16	1	W
715 (0x2CB)	6	Wi-Fi module MAC address	16	0 to 65535	R
718 (0x2CE)	1	Firmware version of the Wi-Fi module	16	0 to 65535	R
719 (0x2CF)	1	Wi-Fi module status High byte 0: not configured 1: not connected 2: connected 3: reconnecting Low byte 0: not connected 1: high signal strength 2: medium signal strength 3: low signal strength	16	0 to 65535	R
Notes	<p>“R”: Read                      “W”: Write                      “F”: Settings are recorded in flash by default  <b>Warning:</b> Frequent writing to the Flash can cause it to become corrupt.</p>				

## 8. Related Tools

### 8.1 LabVIEW

LabVIEW is a system-design platform and development environment and is ideal for acquiring, analyzing, and presenting data. LabVIEW provides a graphical development environment that allows you to drag and drop pre-built objects to quickly create data acquisition, instrumentation and control systems, thereby boosting productivity and reducing development time. LabVIEW makes it possible to quickly create user interfaces that enable interactive control of software systems then specify the functionality of your system, by simply assembling a block diagram, which is a natural design notation for scientists and engineers.

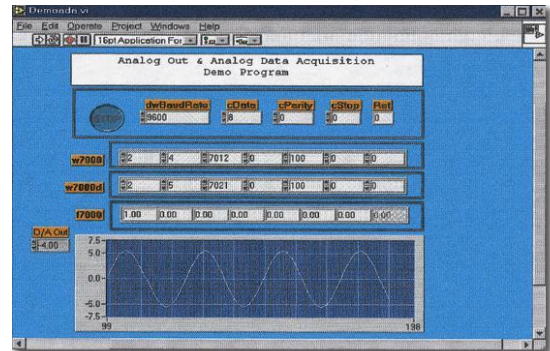

A document that describes how to link LabVIEW to a SL device using the Modbus protocol can be found at:

[http://ftp.icpdas.com/pub/cd/6000cd/napdos/et7000/document/application/labview/labview\\_modbus\\_eng.pdf](http://ftp.icpdas.com/pub/cd/6000cd/napdos/et7000/document/application/labview/labview_modbus_eng.pdf)

### 8.2 OPC Server

OPC (OLE for Process Control) was the first standard resulting from the collaboration of a number of leading worldwide automation suppliers working in cooperation with Microsoft. Originally based on Microsoft's OLE COM (Component Object Model) and DCOM (Distributed Component Object Model) technologies, the specification defines a standard set of objects, interfaces and methods for use in process control and manufacturing automation applications to facilitate interoperability.

A wide range of different mechanisms are provided by various vendors that allow access to a variety of devices via specific applications. However, if an OPC server is provided for the device, other applications will also be able to access the device via the OPC interface.



## 8.3 SCADA

SCADA stands for Supervisor Control and Data Acquisition and is a PC-based production automation and control system.

SCADA is widely used in many fields, including power generation, water systems, the oil industry, the chemical, and the automobile industry. Different fields require different functions, but they all have the same common requirements:

- ✓ Graphical interface
- ✓ Process mimicking
- ✓ Real-time and historical trend data
- ✓ Alarm systems
- ✓ Data acquisition and recording
- ✓ Data analysis
- ✓ Report generation

### Accessing the SL Series Module

SCADA software is able to access SL series devices using the Modbus communication protocol without the need for other software drivers.

### Popular SCADA Software

Some of the more popular SCADA software includes **Citect, ICONICS, iFIX, InduSoft, Intouch, Entivity Studio, Entivity Live, Entivity VLC, Trace Mode, Wizcon, and Wonderware**, etc.

In the following sections, three popular brands of SCADA software are introduced, together with detailed instructions of how to use them to communicate with SL series modules using the Modbus TCP protocol.

## ■ InduSoft

InduSoft Web Studio is a powerful, integrated collection of automation tools that includes all the building blocks needed to develop modern Human Machine Interfaces (HMI), Supervisory Control and Data Acquisition (SCADA) systems, and embedded instrumentation and control applications. InduSoft Web Studio's application runs in native Windows NT, 2000, XP, CE and CE .NET environments and conforms to industry standards such as Microsoft .NET, OPC, DDE, ODBC, XML, and ActiveX.

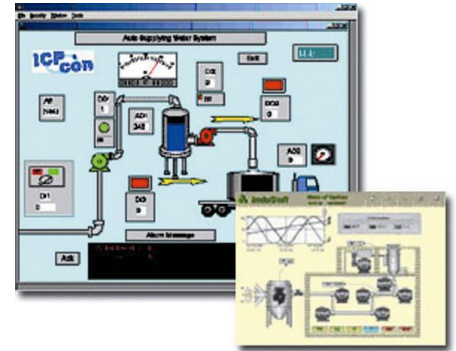

The document describing how to link InduSoft to the SL series module using the Modbus protocol is located at:

[http://ftp.icpdas.com/pub/cd/6000cd/napdos/et7000/document/application/indusoft/indusoft\\_modbus\\_eng.pdf](http://ftp.icpdas.com/pub/cd/6000cd/napdos/et7000/document/application/indusoft/indusoft_modbus_eng.pdf)

## ■ Citect



CitectSCADA is a fully integrated Human Machine Interface (HMI) / SCADA solution that enables users to increase return on assets by delivering a highly scalable, reliable control and monitoring system. Easy-to-use configuration tools and powerful features enable the rapid development and deployment of solutions for applications of any size.

The document describing how to link Citect to the SL module using the Modbus protocol is located on

[http://ftp.icpdas.com/pub/cd/6000cd/napdos/et7000/document/application/ifix/ifix\\_mbtcp.pdf](http://ftp.icpdas.com/pub/cd/6000cd/napdos/et7000/document/application/ifix/ifix_mbtcp.pdf)

## ■ iFix



The document describing how to link iFix to the SL series module using the Modbus protocol is located at:

[http://ftp.icpdas.com/pub/cd/6000cd/napdos/et7000/document/application/citect/citect\\_mbtcp.pdf](http://ftp.icpdas.com/pub/cd/6000cd/napdos/et7000/document/application/citect/citect_mbtcp.pdf)

## Appendix: FAQ

### A. How do avoid a browser access error that causes a blank page to be displayed when using Internet Explorer.

Disable the IE cache using the following procedure:

**Step 1:** In the IE browser, select the “Internet Options...” item from the “Tools” menu.

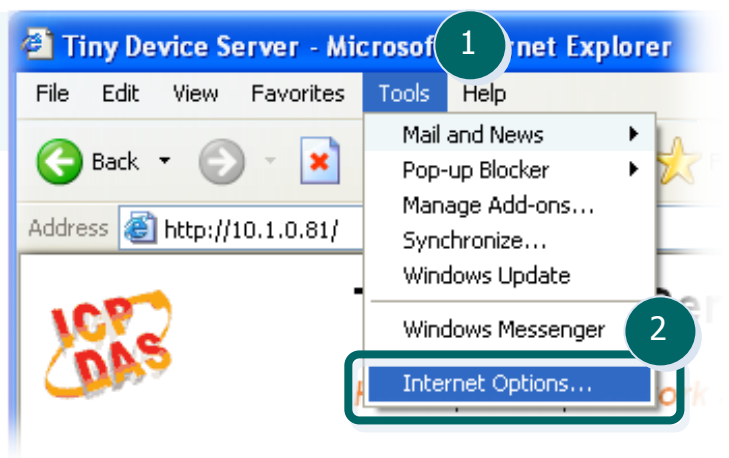

**Step 2:** Click the “General” tab and then click the “Settings...” button in the Temporary Internet files area of the Internet Options dialog box.

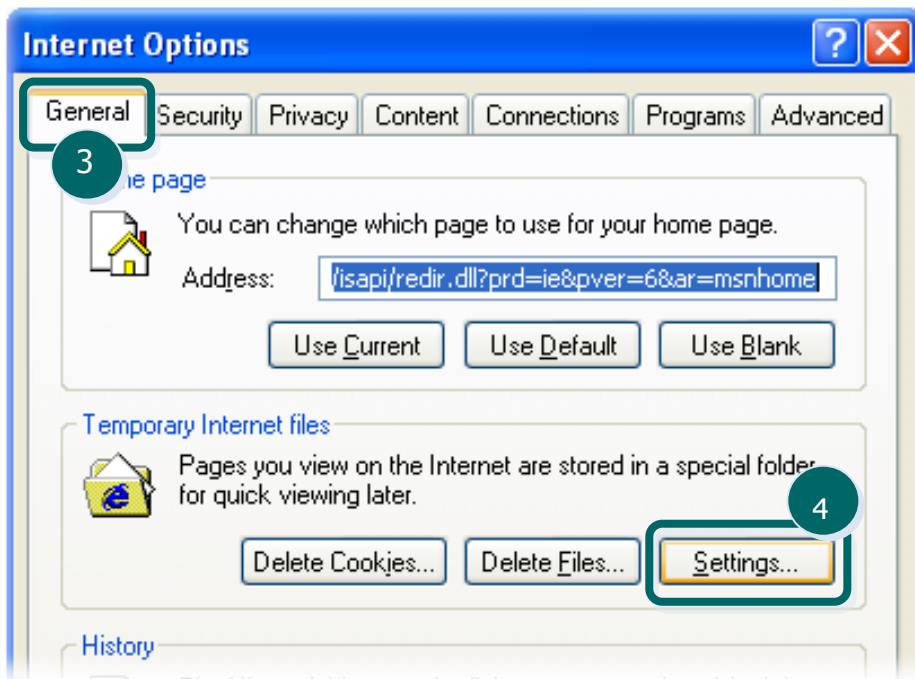

**Step 3:** Click the “Every visit to the page” option, and then click the “OK” button in both the **Settings** and the **Internet Options** dialog boxes.

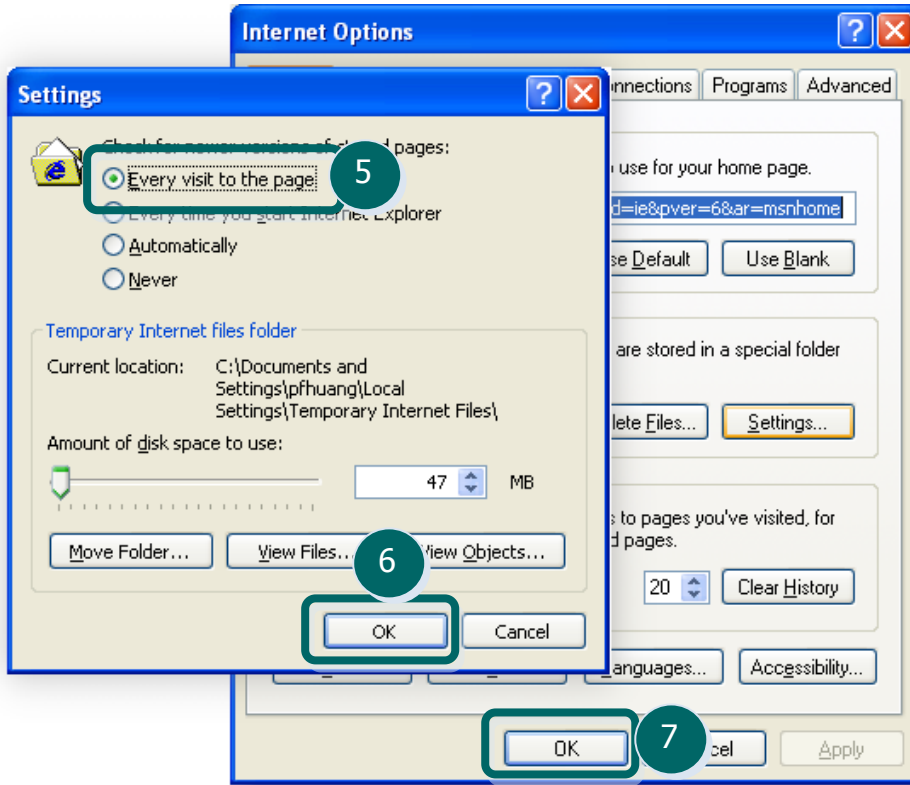

**Step 4:** Click the “Refresh” button on the browser or press **F5** on your keyboard to refresh the SL series web server page, or re-open IE.

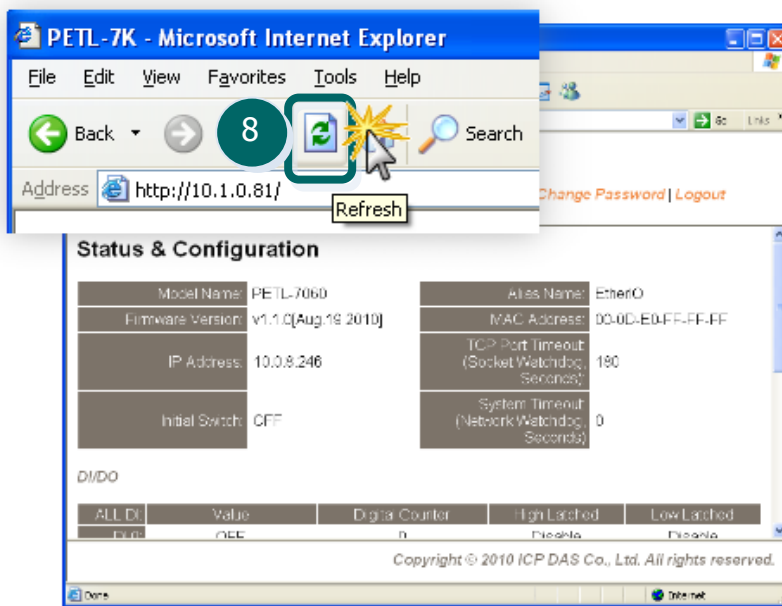

## B. How to update the firmware via Ethernet?

If the module is not functioning correctly (e.g. there is no response to a search request, or if the system LED is continuously displayed as either OFF or ON), download a new image of the firmware from the ICPDAS web site and then update the firmware.

The firmware of the SL module is located at:  
<http://ftp.icpdas.com.tw/pub/cd/sl/firmware/>

To update the Firmware for your SL series module, connect SL module and PC in the same sub-network. Please note that there should be only one network card in the PC.

Download and install the eSearch utility.  
<http://ftp.icpdas.com/pub/cd/6000cd/napdos/software/esearch/>

Run the eSearch utility. Click on the Search Server button and it should find the SL module.

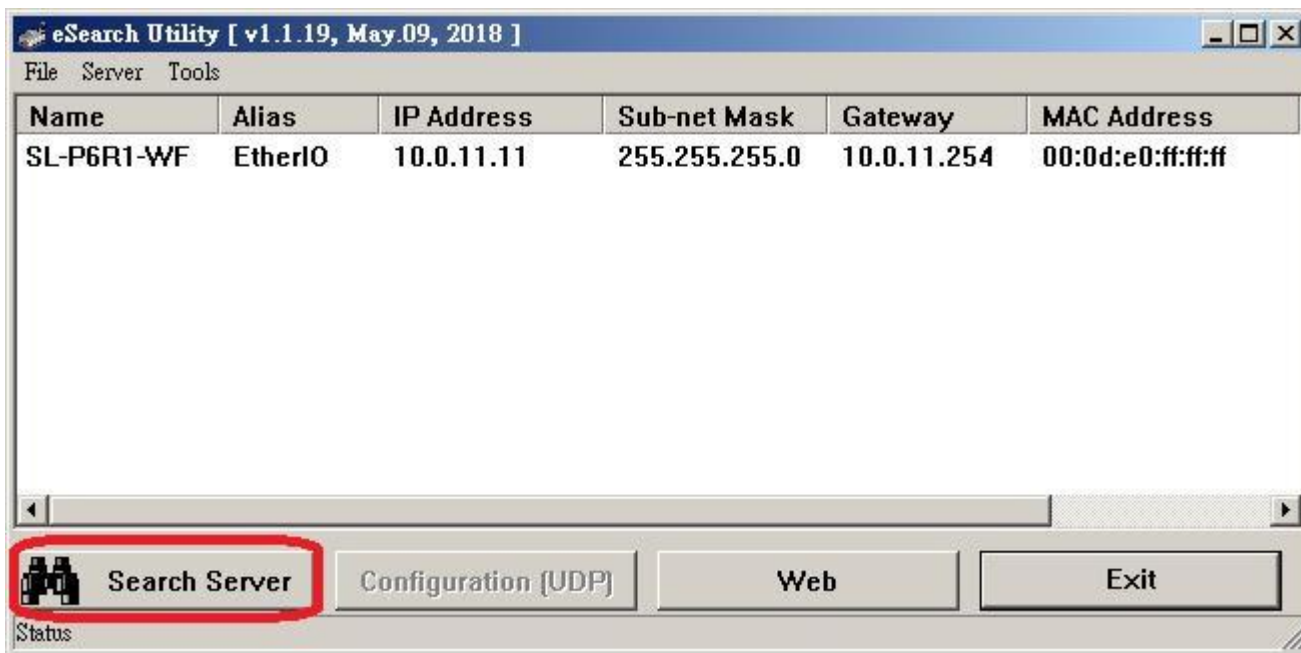

Right click on the SL module name then select Firmware Update.

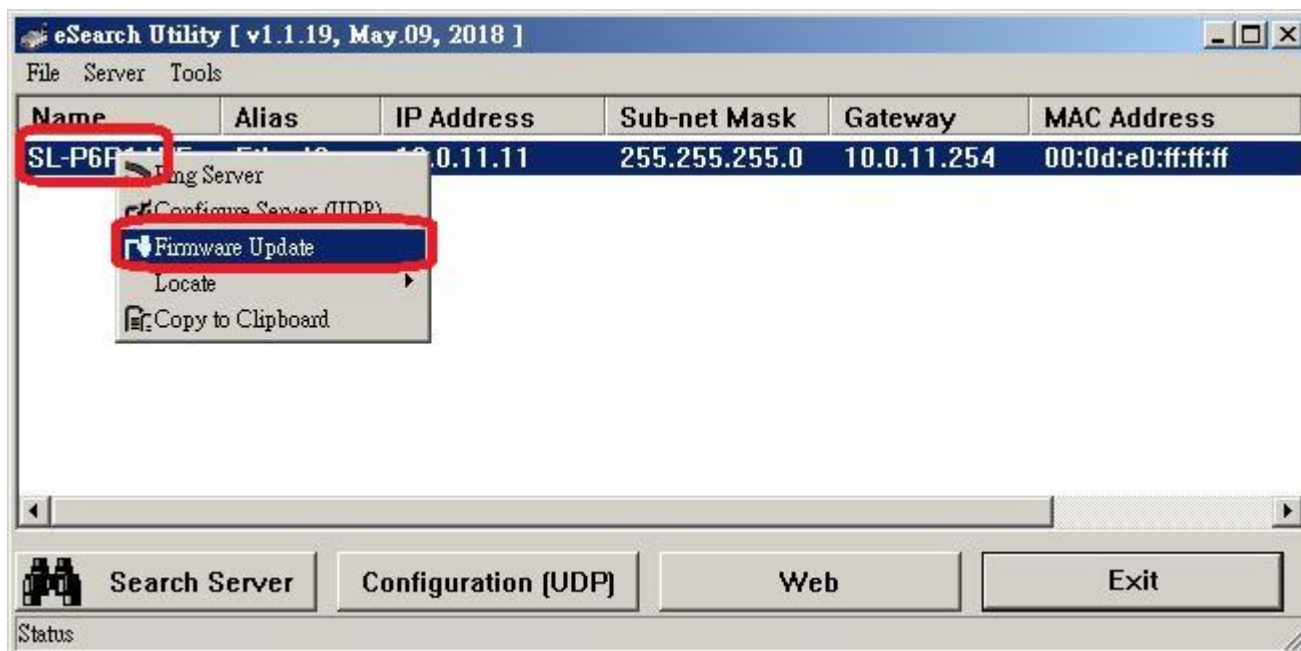

Select the firmware file and click on the Open button.

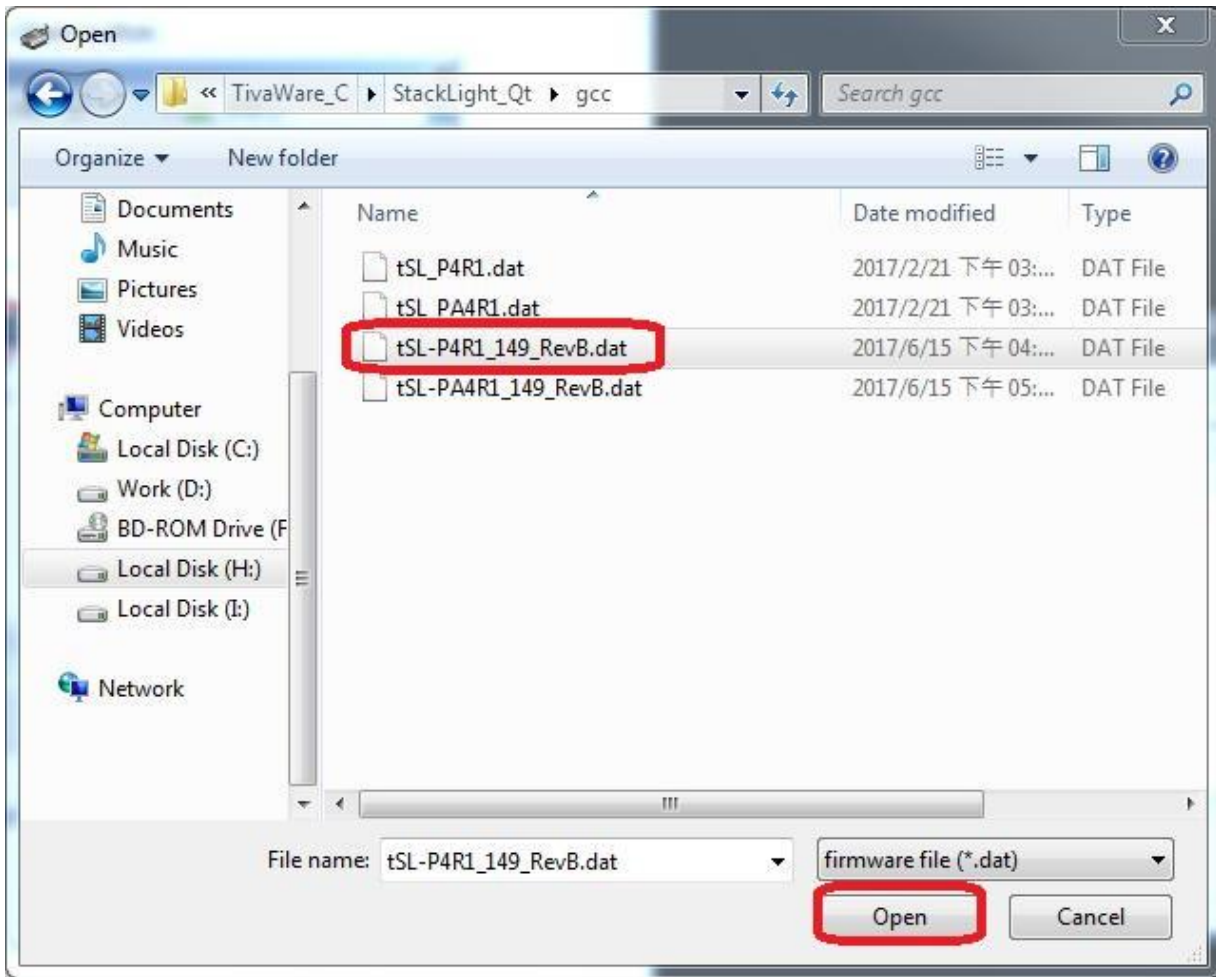

Make sure the IP address and MAC address are correct. Click on the OK button.



A command prompt window will be displayed to show the progress.

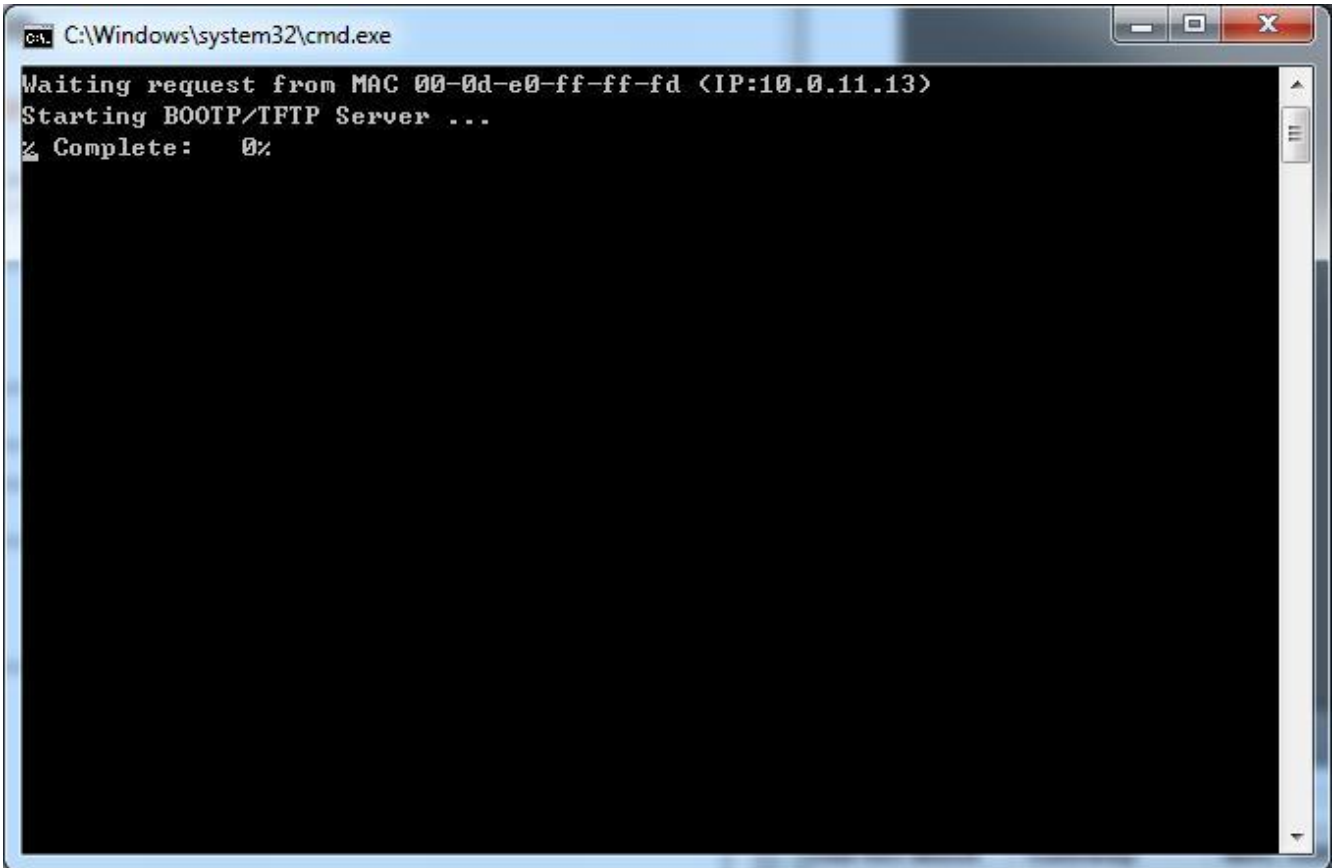

Log in the SL web page. Click on the Network tab then click on the Update button.

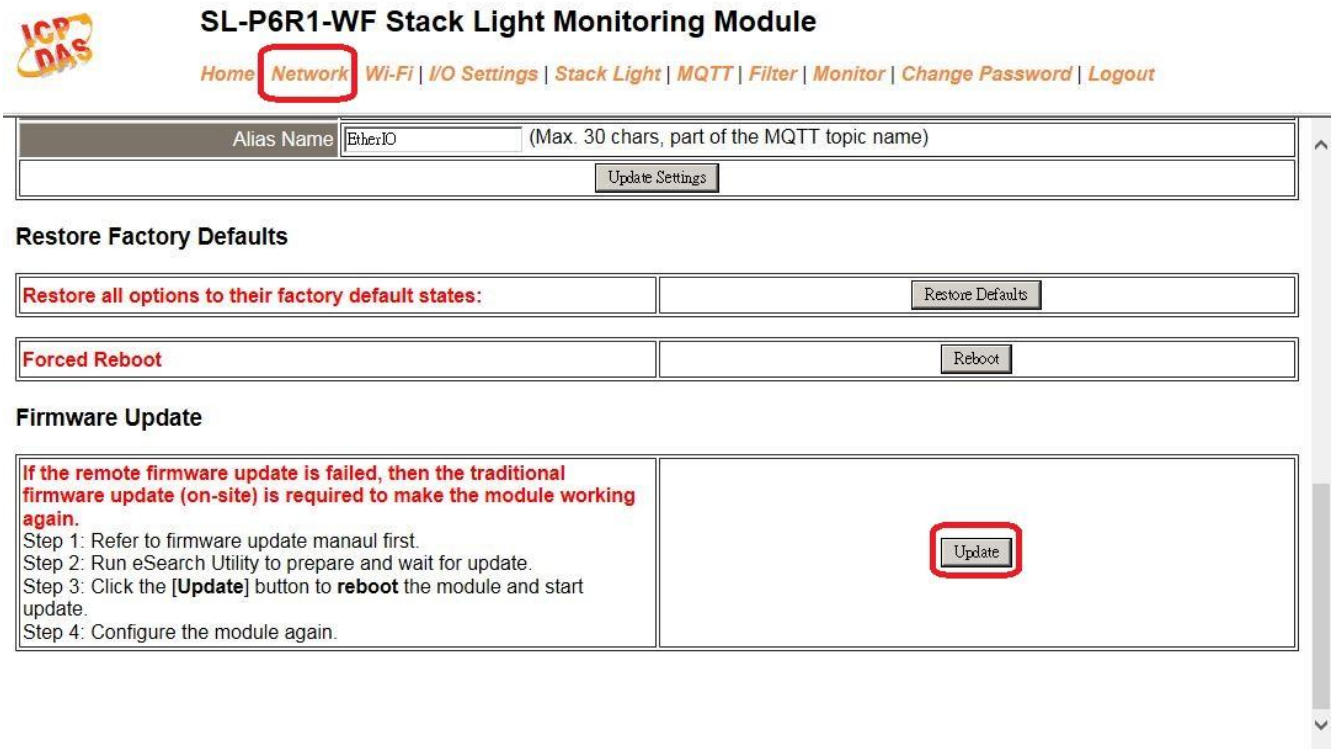

Copyright © 2016 ICP DAS Co., Ltd. All rights reserved.



When it shows “% Complete: 100%”, the update is finished. You can close the command prompt window.

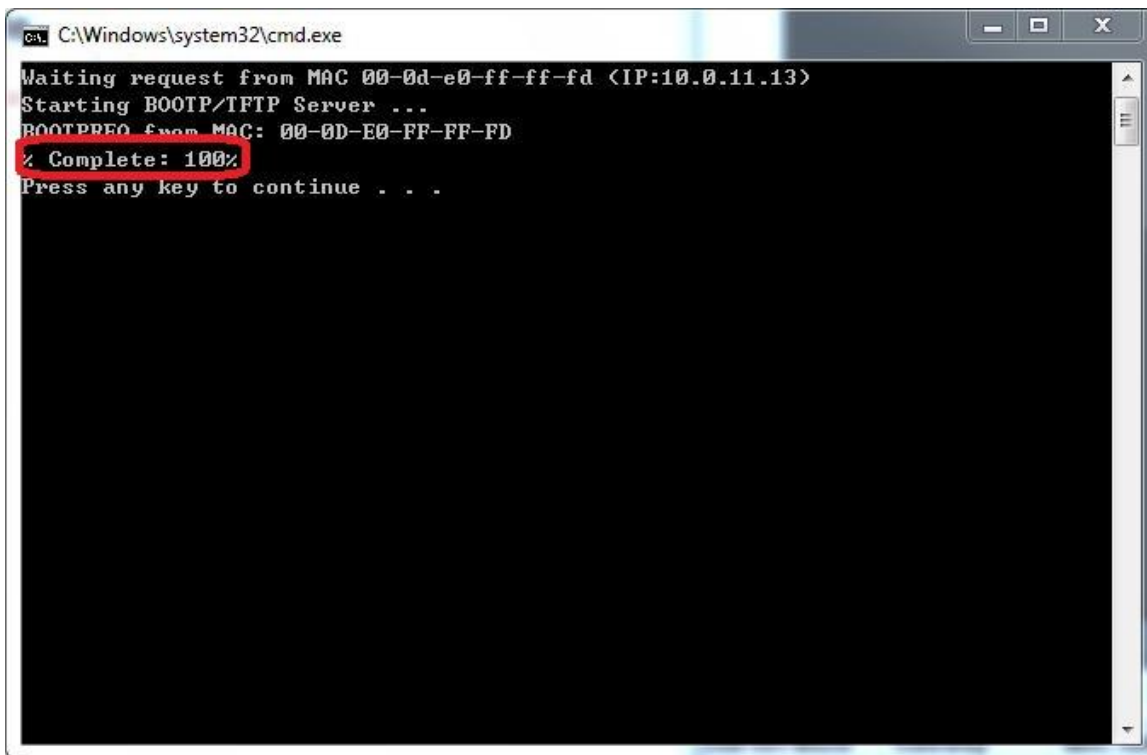

Re-log in the SL web page and check the firmware version.



### SL-P6R1-WF Stack Light Monitoring Module

[Home](#) | [Network](#) | [Wi-Fi](#) | [I/O Settings](#) | [Stack Light](#) | [MQTT](#) | [Filter](#) | [Monitor](#) | [Change Password](#) | [Logout](#)

Model Name:	SL-P6R1-WF	Alias Name:	EtherIO
Firmware Version:	B1.5.4 [Aug.14, 2018]	MAC Address:	00-0D-E0-FF-FF-FF
IP Address:	10.0.11.11	Initial Switch:	OFF
TCP Port Timeout: (Socket Watchdog, Seconds):	180	System Timeout: (Network Watchdog, Seconds)	0

### C. Why is the Host computer unable to ping or search for the SL series module?

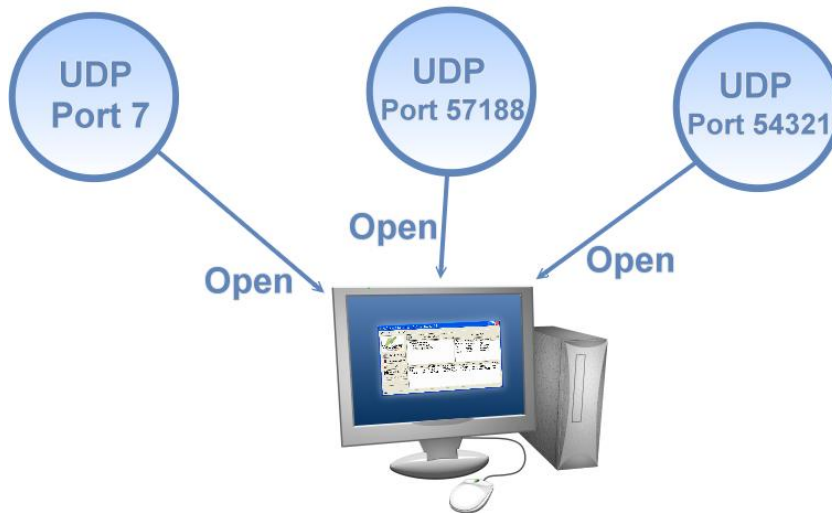

The Host computer can only establish a communication with a module through specific ports. Confirm with your network administrator that access to UDP Port 7, Port 57188 and Port 54321 is not being denied by another network device.

The following provides more detailed information related to TCP/UDP ports:

**TCP Port:**

Port Number	Description
80	HTTP (HyperText Transport Protocol)
502	Modbus Data Port

**UDP Port:**

Port Number	Description
7	Echo (Ping)
57188	UDP Search Request
54321	UDP Search Response

## D. What is Digital-Input Filter (DI Filter)?

A: An input signal can come from a myriad of sources, such as buttons, switches, sensors, or relays, etc. Each of these types of mechanical device also contributes to a common problem - “**contact bounce**”.

The switch between Digital Input states is usually accompanied by a number of unwanted pulses, known as “switch bounce”. In certain environments and situations, these input signals may inevitably generate an unstable signal or noise, which can potentially cause incorrect data counting or operation failure. Consequently, it is imperative that these errors are removed from the input signals, especially if the signals are used in crucial applications.

A low-pass Digital Input filter is a software function that can be used to eliminate high-frequency interference from input signals. The input state will only be changed when the width of any new signal is greater than the value specified as the filtering time, meaning that short, high-frequency interference pulses will be ignored, as illustrated in the diagram below. This is especially useful when attempting to eliminate contact bounce.

